



Bu proje Avrupa Birliđi ve Türkiye Cumhuriyeti tarafından finanse edilmektedir

BUTEXCOMP

“Kompozit Malzeme ve Teknik Tekstil Prototip Üretim ve Uygulama Merkezi” Teknik Destek Projesi

Teknik Tekstiller ve Uygulamaları -2

Doç. Dr. Ozan Toprakçı

20-21 Temmuz 2023, Butekom



T.C. SANAYİ VE
TEKNOLOJİ BAKANLIđI



BTSO
BURSA TİCARET VE SANAYİ ODASI



BUTEKOM
Bursa Teknoloji Koordinasyon ve Ar-Ge Merkezi



Bu proje Avrupa Birliđi ve Türkiye Cumhuriyeti tarafından finanse edilmektedir

İÇERİK

- Giriş
- TT için Lif ve İplik Üretimi
- TT için Dokuma Kumaş Üretimi
- TT için Örme Kumaş Üretimi
- TT için Dokusuz Yüzey Üretimi
- TT için Bitim İşlemleri ve Kaplama





Bu proje Avrupa Birliđi ve Türkiye Cumhuriyeti tarafından finanse edilmektedir

3. Bölüm

LİF ve İPLİK ÜRETİMİ



Çekim Yöntemleri



LİF ÜRETİMİ

Bu proje Avrupa Birliği ve Türkiye Cumhuriyeti tarafından finanse edilmektedir

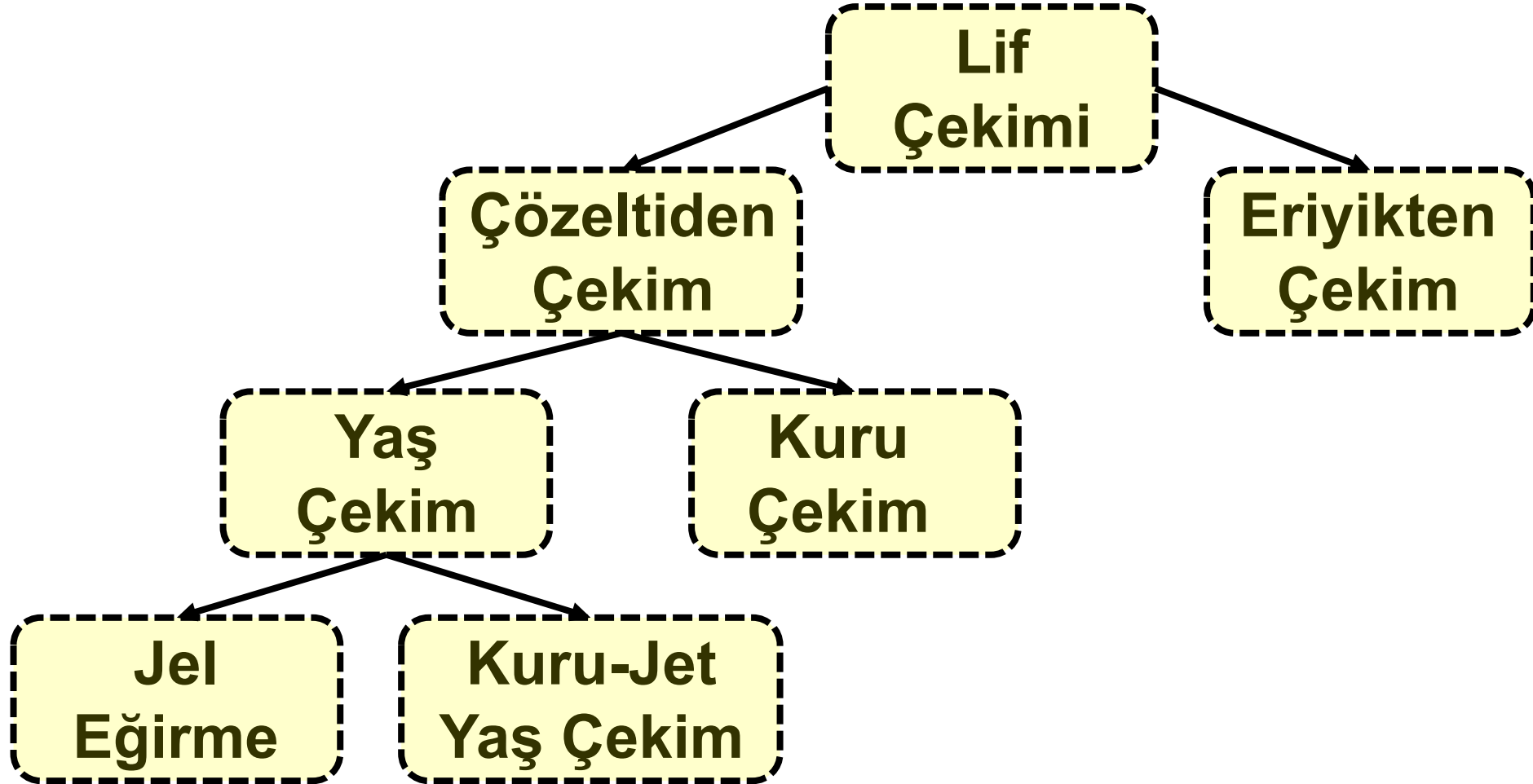

Kesikli Lifler

Ring Eđirme



İPLİK ÜRETİMİ

Bu proje Avrupa Birliđi ve Türkiye Cumhuriyeti tarafından finanse edilmektedir

Pamuk

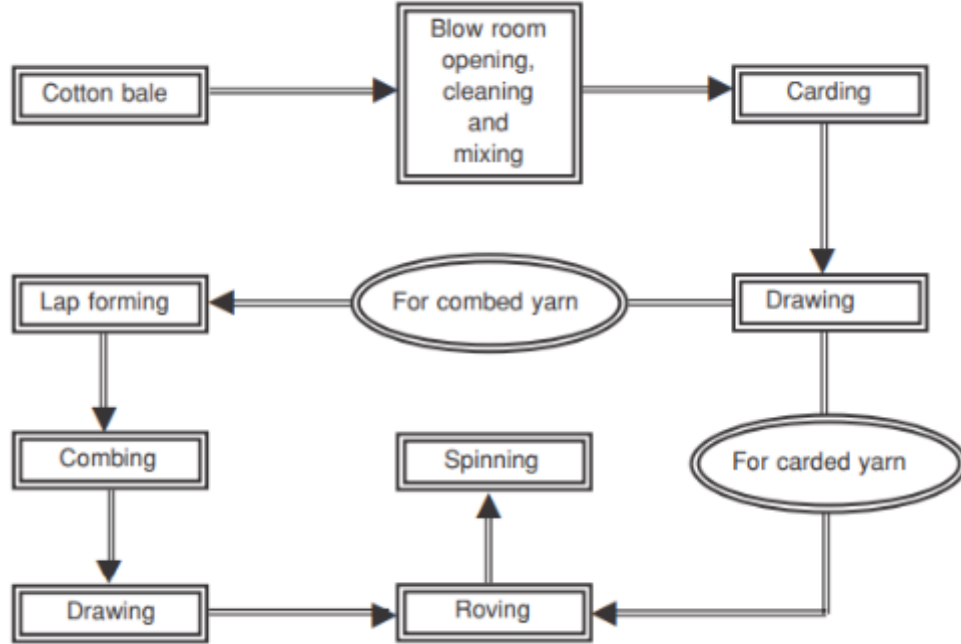

Yün

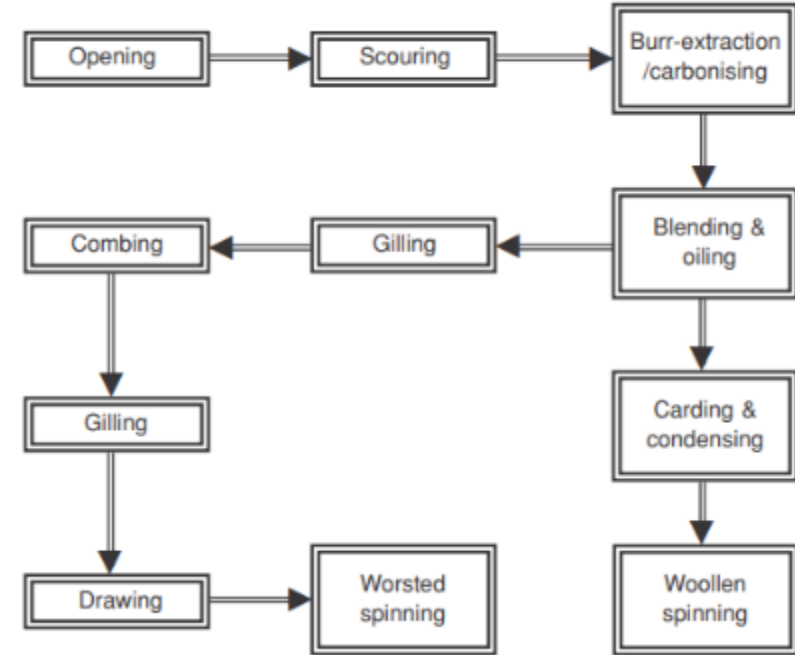

Kesikli Lifler Ring Eğirme



Bu proje Avrupa Birliği ve Türkiye Cumhuriyeti tarafından finanse edilmektedir

İPLİK ÜRETİMİ

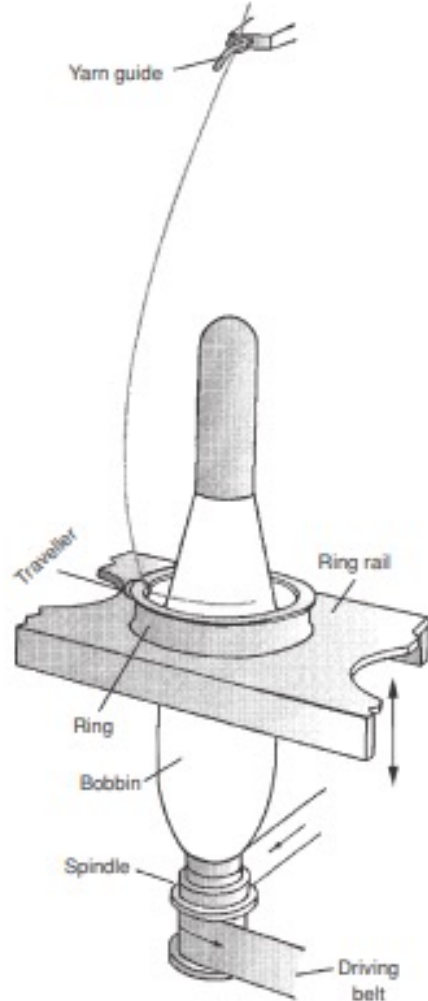

$$N_t = N_s - \frac{V_d}{\pi D_b}$$

$$t = \frac{N_t}{V_d}$$

N_t (rpm):
 N_s (rpm):
 V_d (m/dk):
 D_b (m):
 t (adet/m):

Kopçanın dönüş hızı
Milin dönüş hızı
İplik toplama hızı
Bobin çapı
Birim uzunluktaki büküm
adedi

$$t = \frac{N_s}{V_d}$$



Kesikli Lifler

Kompakt Eğirme



Bu proje Avrupa Birliği ve Türkiye Cumhuriyeti tarafından finanse edilmektedir

İPLİK ÜRETİMİ

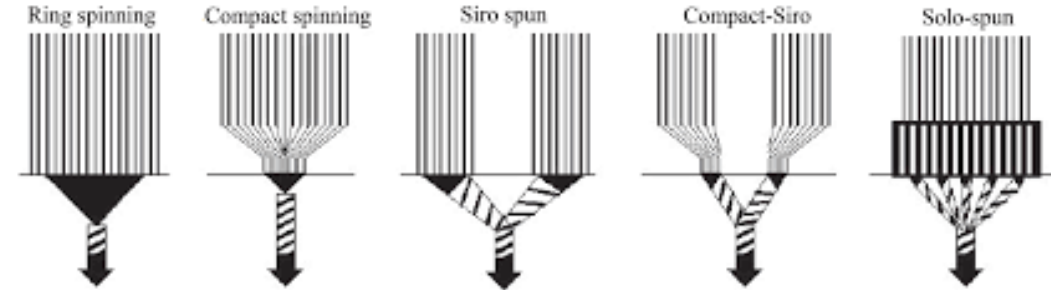
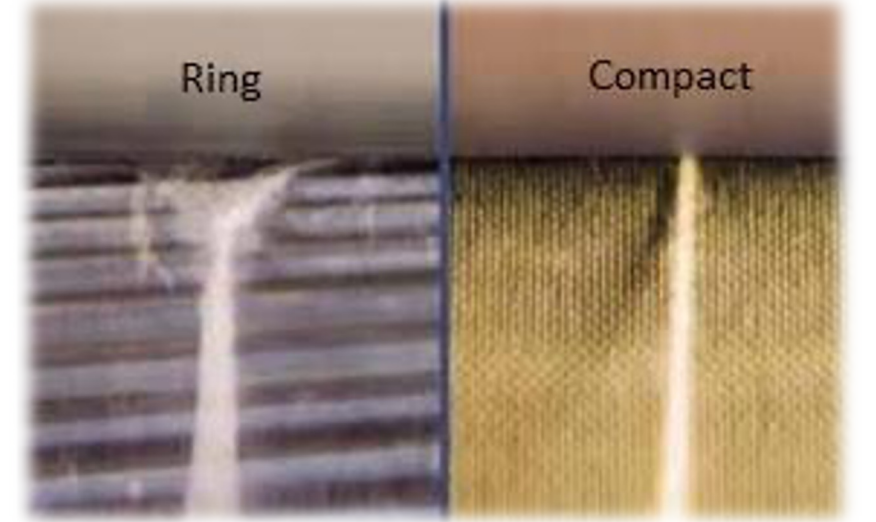
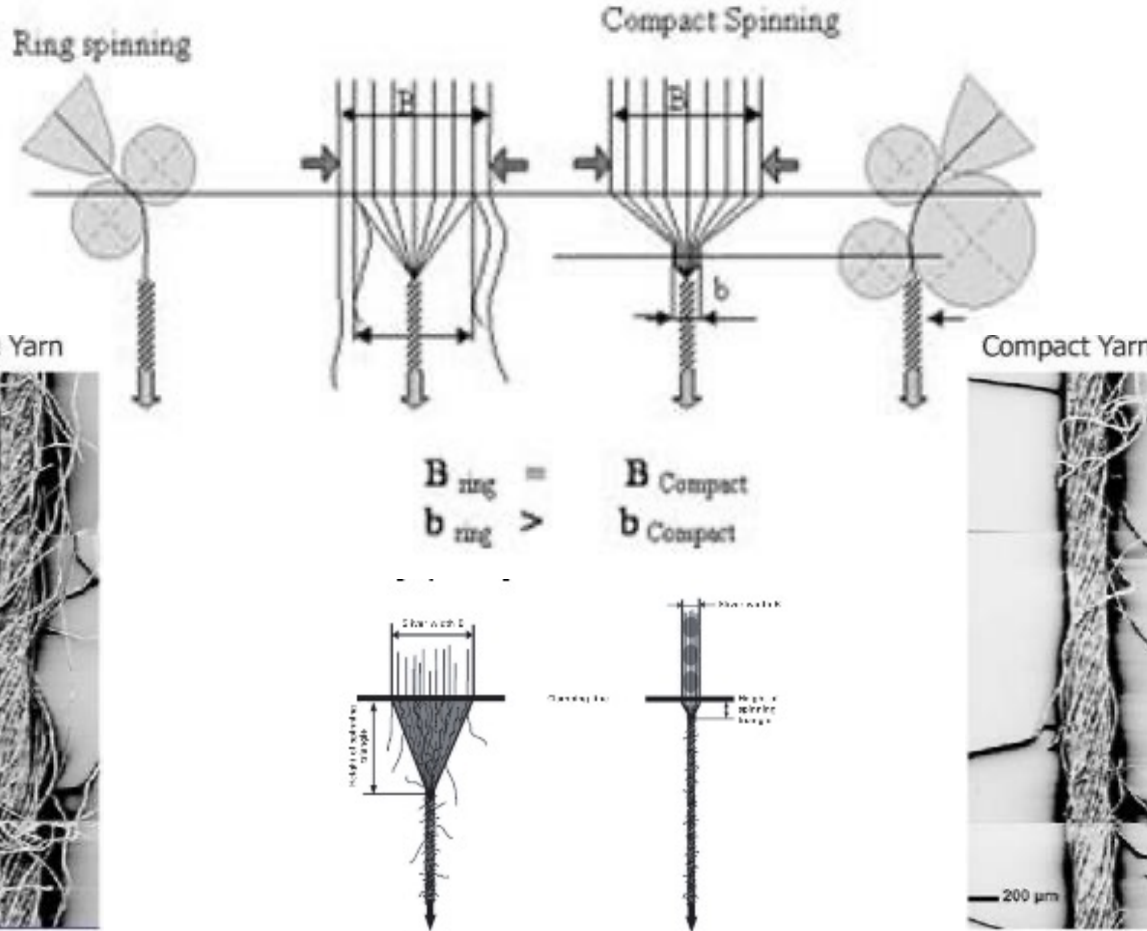

Kesikli Lifler Rotor Eğirme



Bu proje Avrupa Birliği ve Türkiye Cumhuriyeti tarafından finanse edilmektedir

İPLİK ÜRETİMİ

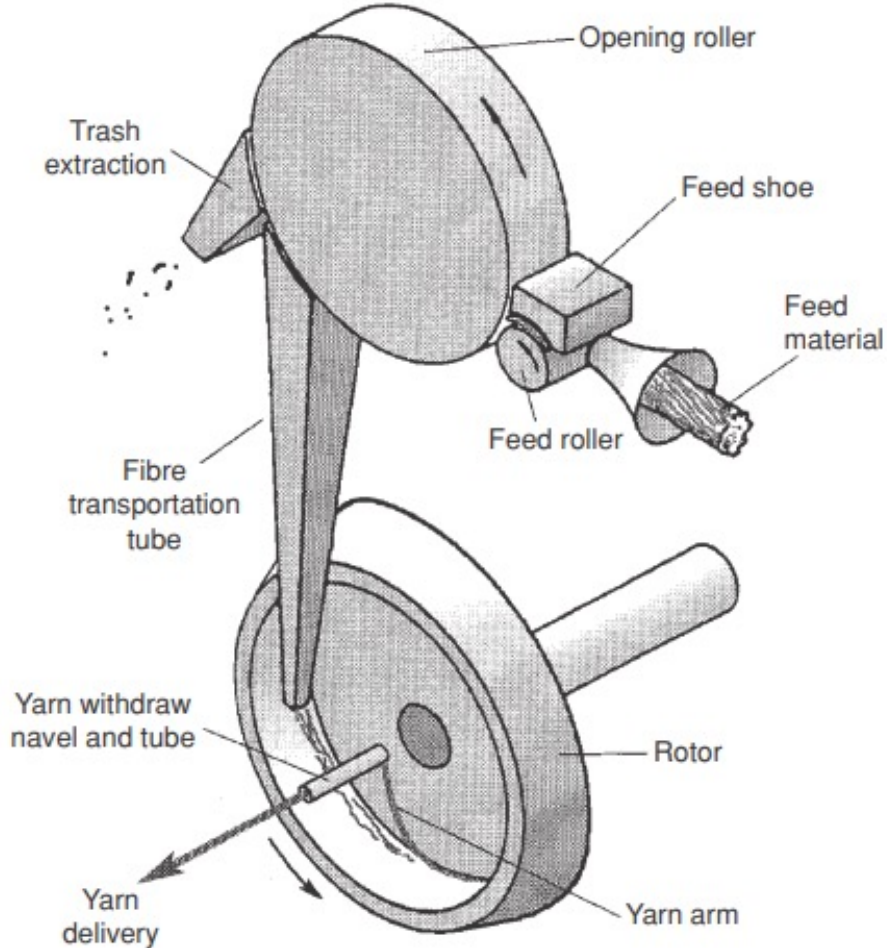

$$t = \frac{N_y}{V_d}$$

$$(N_y - N_r)\pi D = V_d$$

$$t = \frac{N_r}{V_d}$$

$$\beta = \frac{N_r}{N_y - N_r} = \frac{N_r}{V_d} \pi D = t\pi D$$

N_y (rpm):

N_r (rpm):

V_d (m/dk):

D (m):

t (adet/m):

β :

İplik dönüş hızı

Rotor dönüş hızı

İplik toplama hızı

Rotor çapı

Birim uzunluktaki büküm
adedi

Back-doubling oranı



Kesikli Lifler Friksiyon Eğirme



Bu proje Avrupa Birliği ve Türkiye Cumhuriyeti tarafından finanse edilmektedir

İPLİK ÜRETİMİ

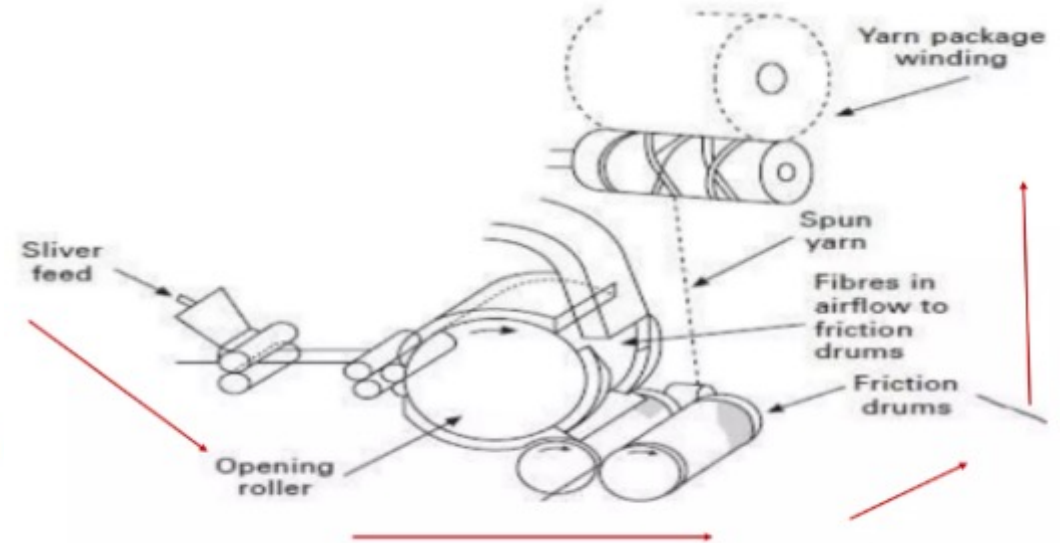
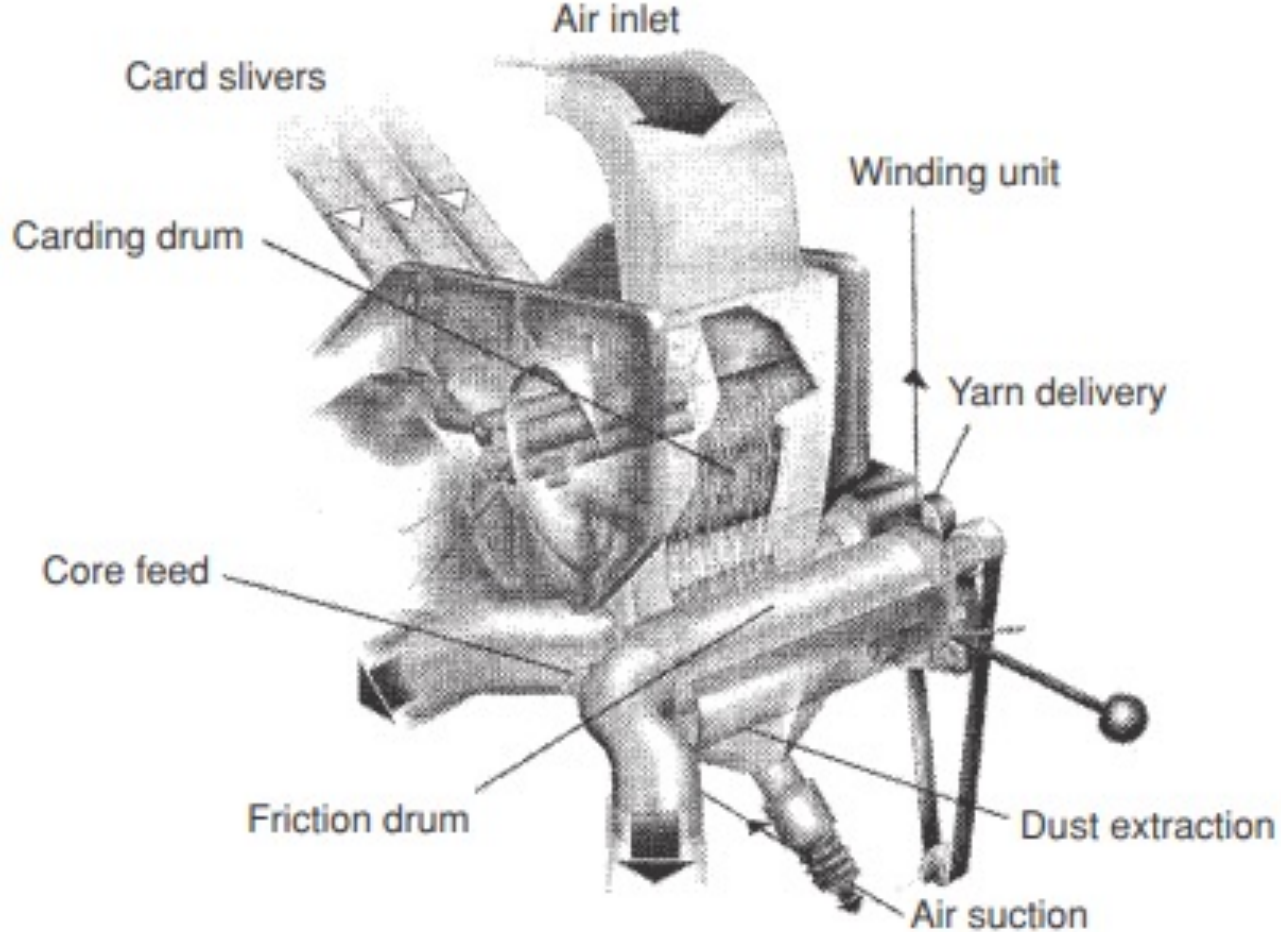
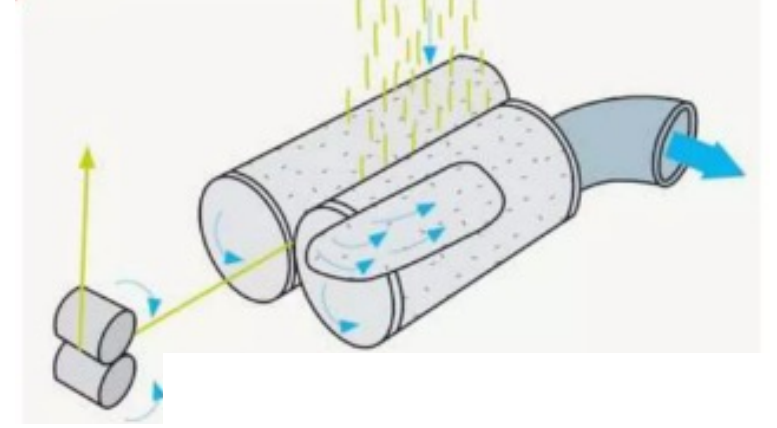

Kesikli Lifler Friksiyon Eğirme



Bu proje Avrupa Birliği ve Türkiye Cumhuriyeti tarafından finanse edilmektedir

İPLİK ÜRETİMİ

DREF-1

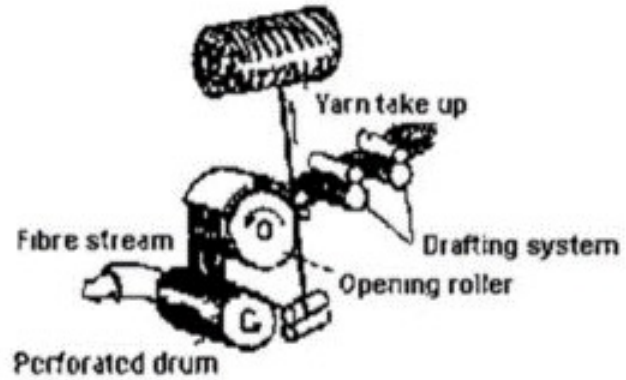

DREF-2

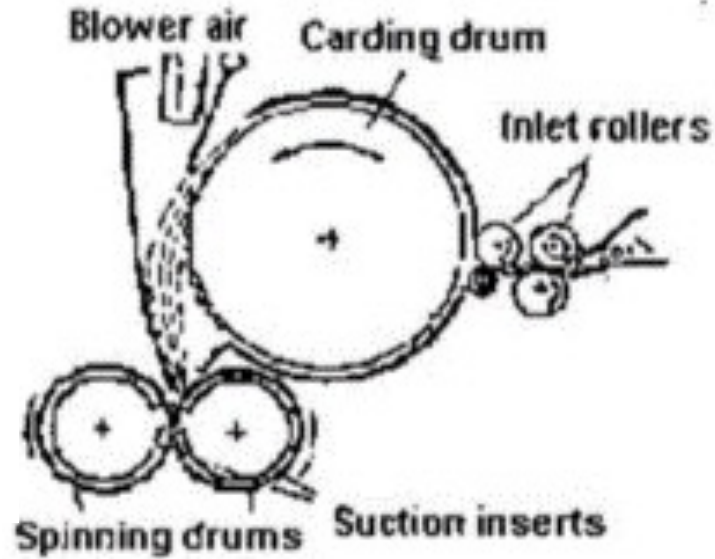

DREF-3

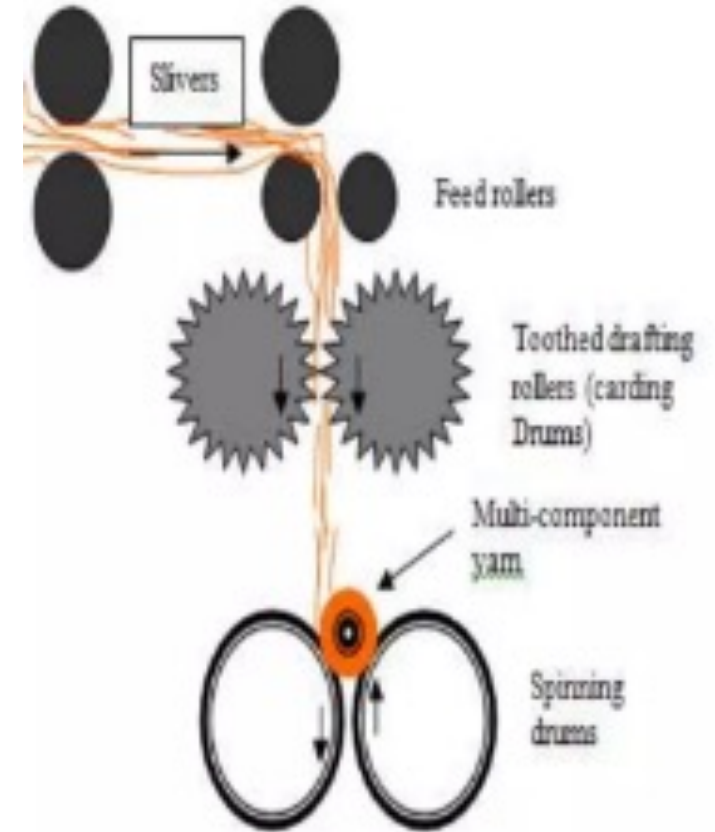

Kesikli Lifler Çekirdek (Wrap) Eğirme



İPLİK ÜRETİMİ

Bu proje Avrupa Birliği ve Türkiye Cumhuriyeti tarafından finanse edilmektedir

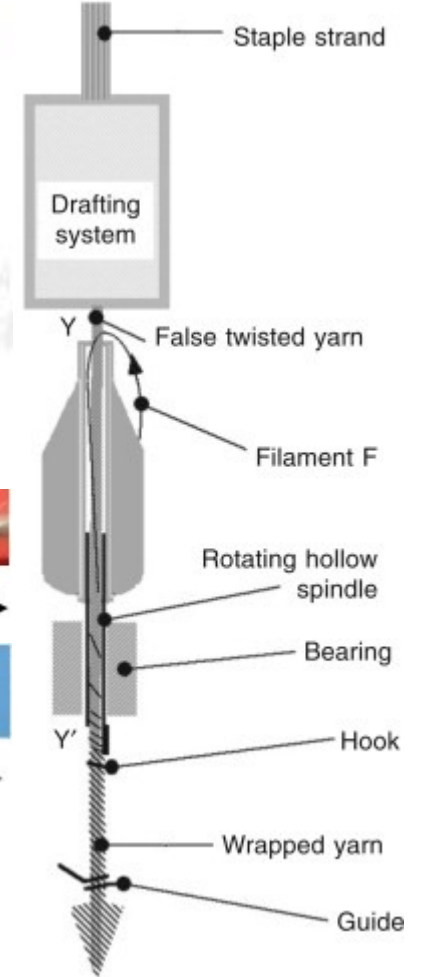
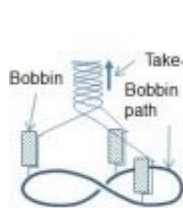
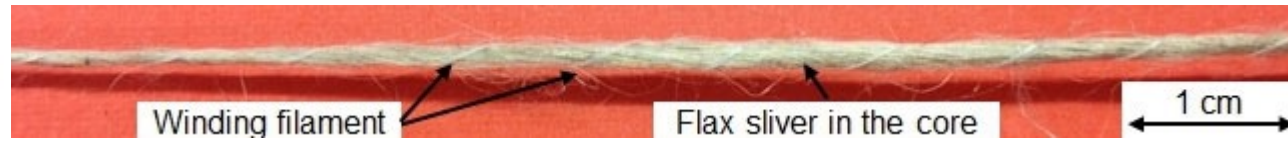
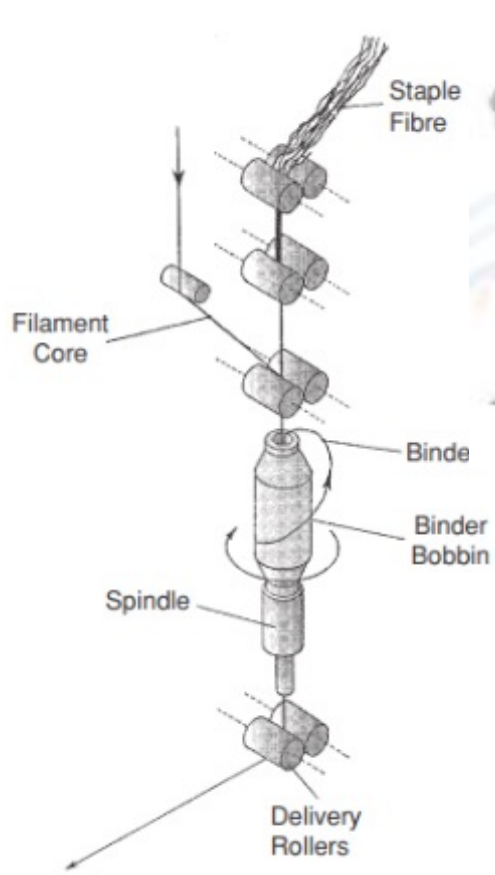

Kesikli Lifler Hava-Jetli Eğirme



Bu proje Avrupa Birliği ve Türkiye Cumhuriyeti tarafından finanse edilmektedir

İPLİK ÜRETİMİ

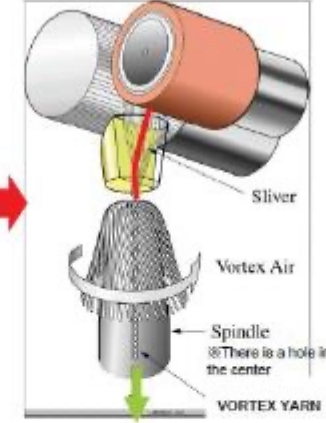
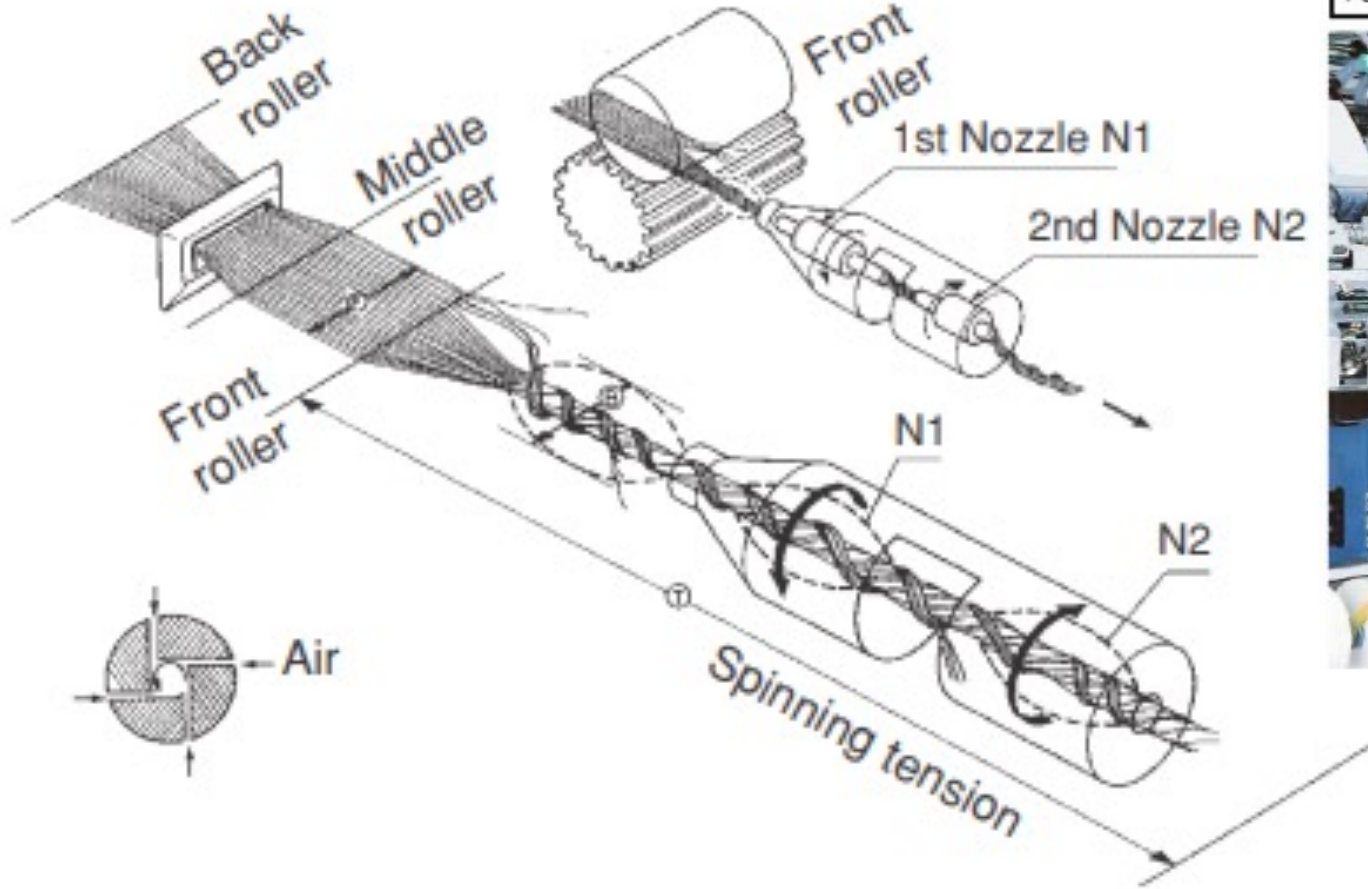

While the roller holds the end of the fiber, the tip of the fiber goes to the hole of the spindle.

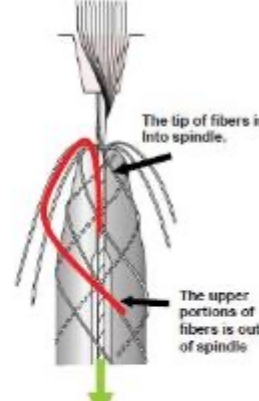

When the end of the fiber is release from the roller, fiber does not go through the spindle hole. It laps around the spindle by Vortex air

Hava-Jetli Tekstüre

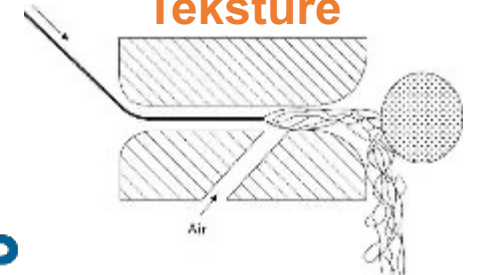

Kesikli Lifler Bükümsüz Eğirme



İPLİK ÜRETİMİ

Bu proje Avrupa Birliği ve Türkiye Cumhuriyeti tarafından finanse edilmektedir

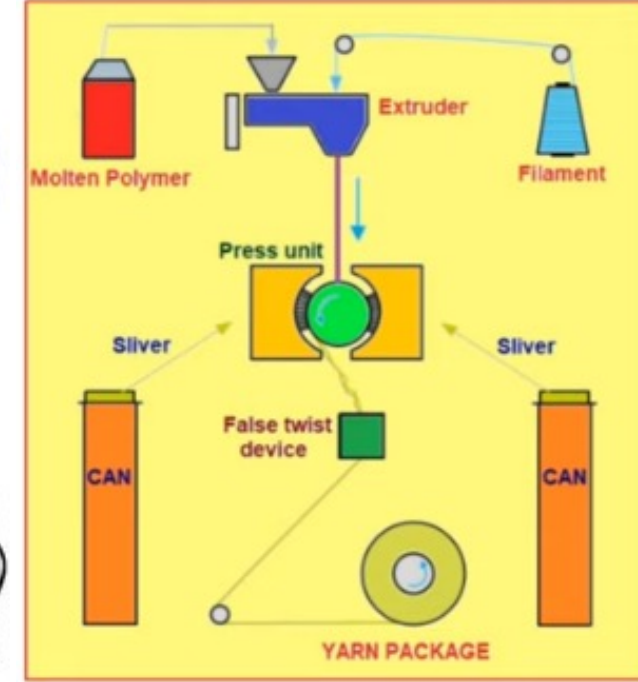
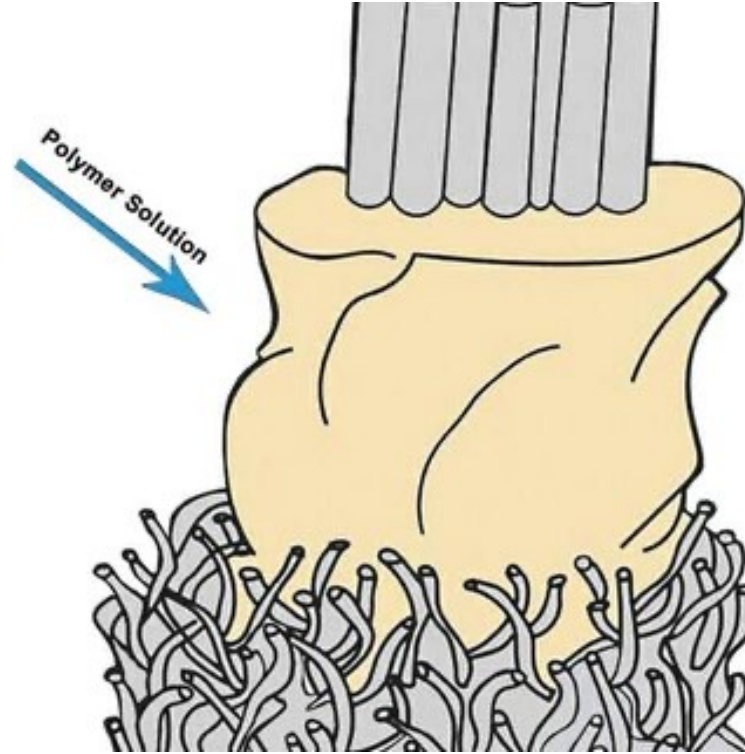
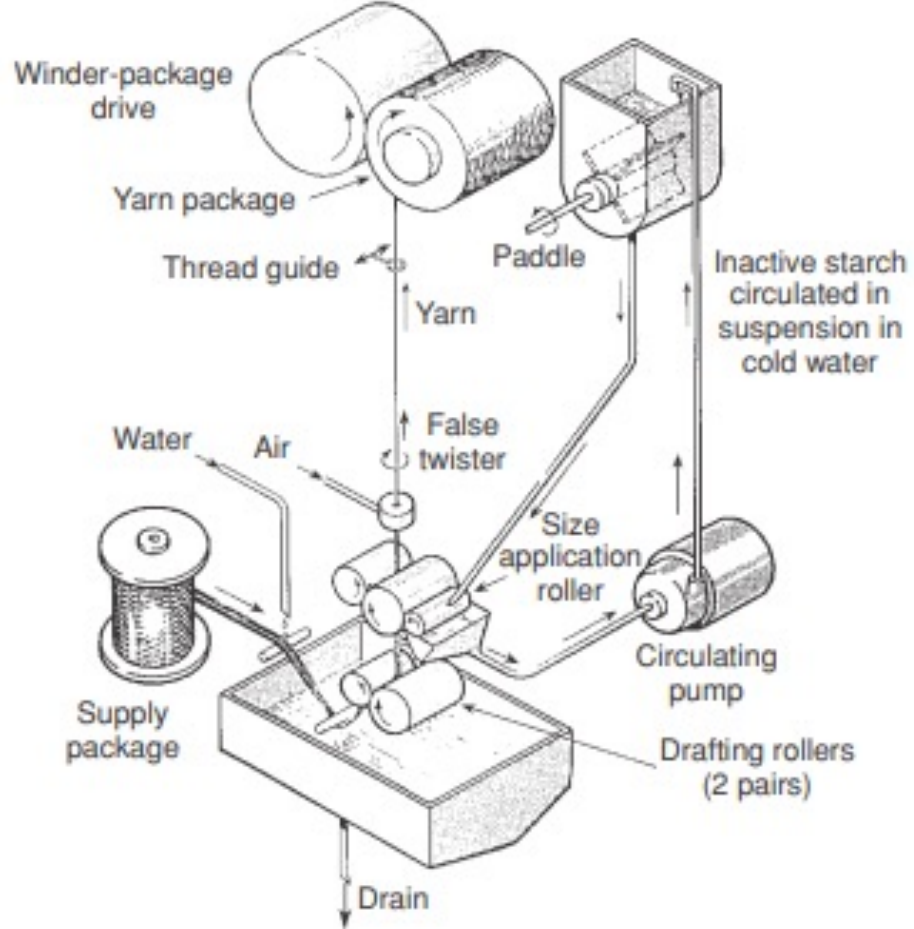

Kesikli Lifler

Katlı İplik Eğirme



İPLİK ÜRETİMİ

Bu proje Avrupa Birliği ve Türkiye Cumhuriyeti tarafından finanse edilmektedir

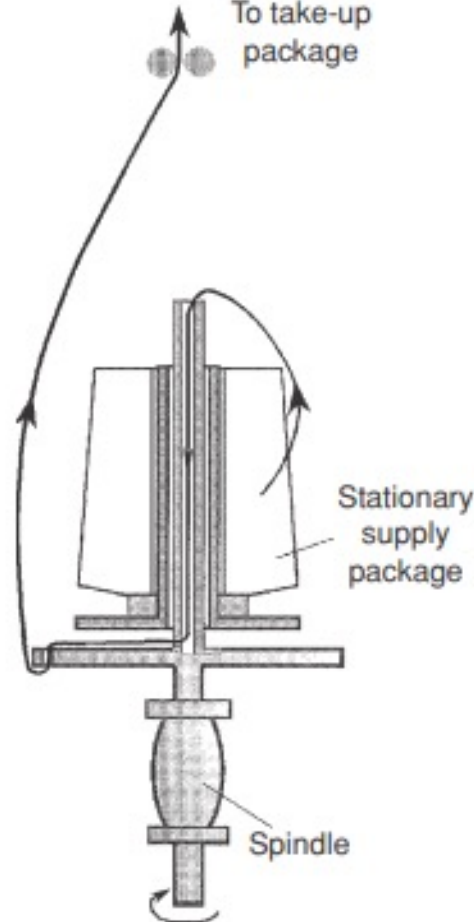
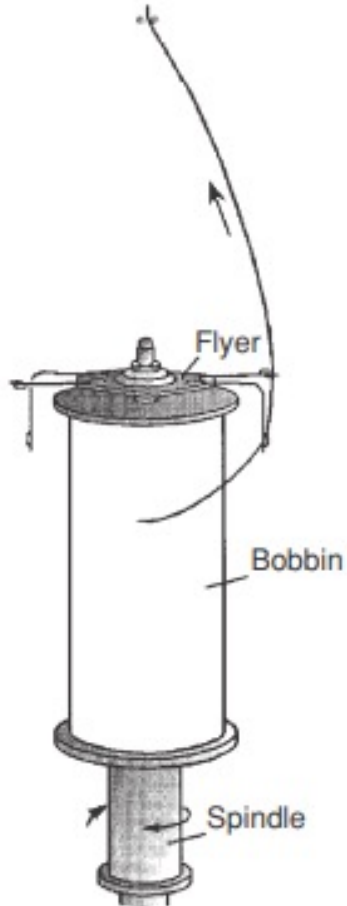

Folded or Ply yarn



Three-Folded or Ply yarn



Four-Folded or Ply yarn



Three fold, two-fold Cabled yarn

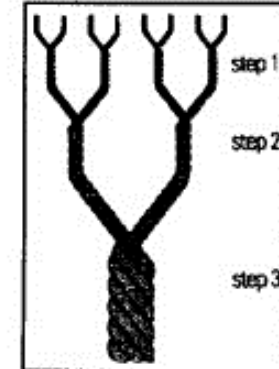

Two-fold, two-fold, two-fold Cabled yarn

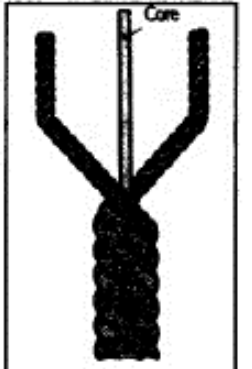

Core Spun yarn



Çekim Yöntemleri



LİF ÜRETİMİ

Bu proje Avrupa Birliği ve Türkiye Cumhuriyeti tarafından finanse edilmektedir

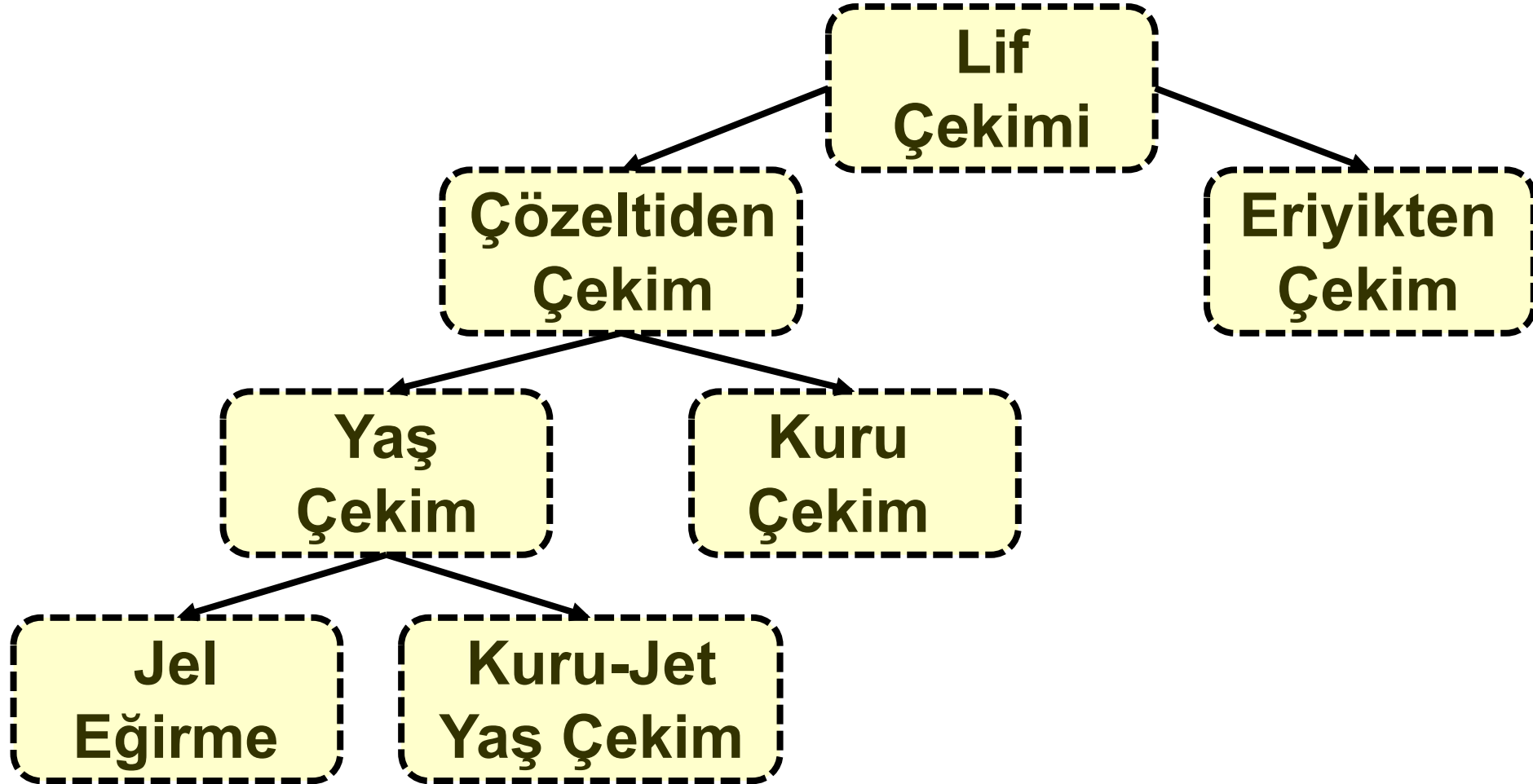

Çekim Yöntemleri



Bu proje Avrupa Birliği ve Türkiye Cumhuriyeti tarafından finanse edilmektedir

LİF ÜRETİMİ

Yaş Çekim

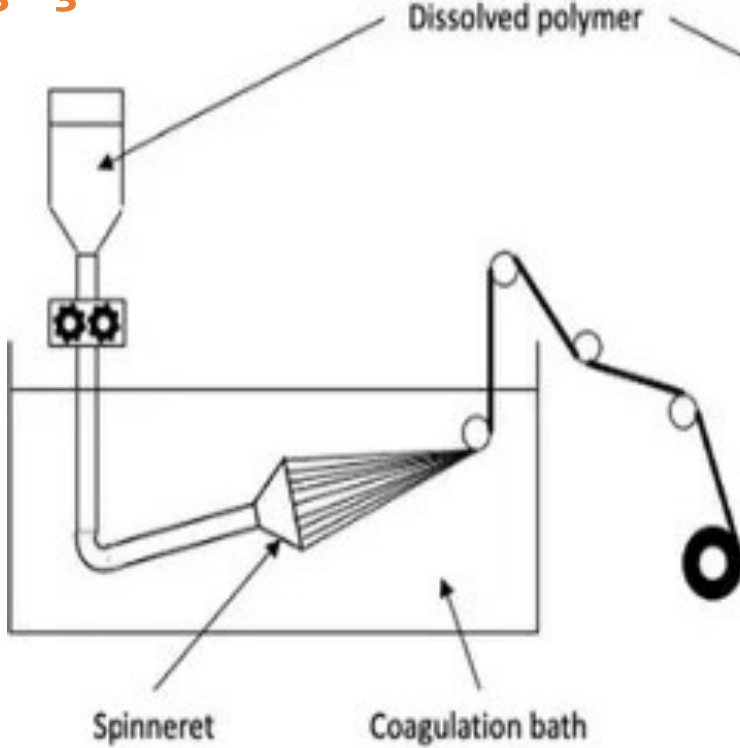

Kuru Çekim

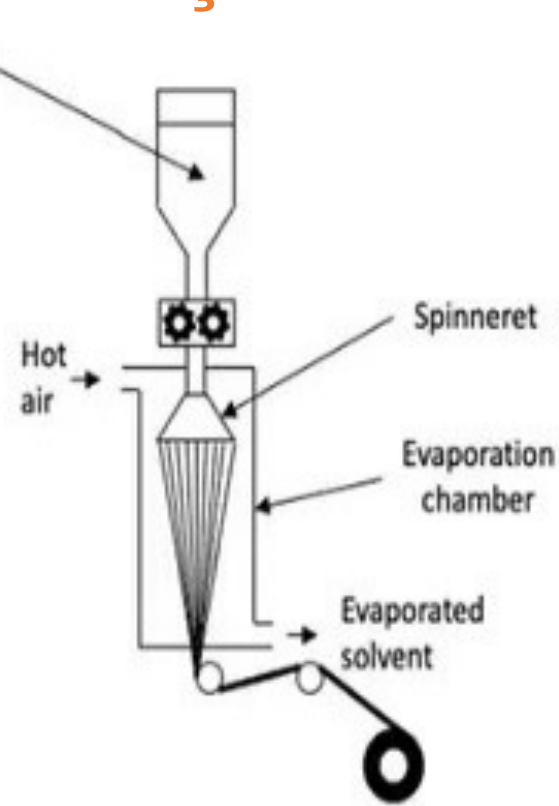

Eriyikten Çekim

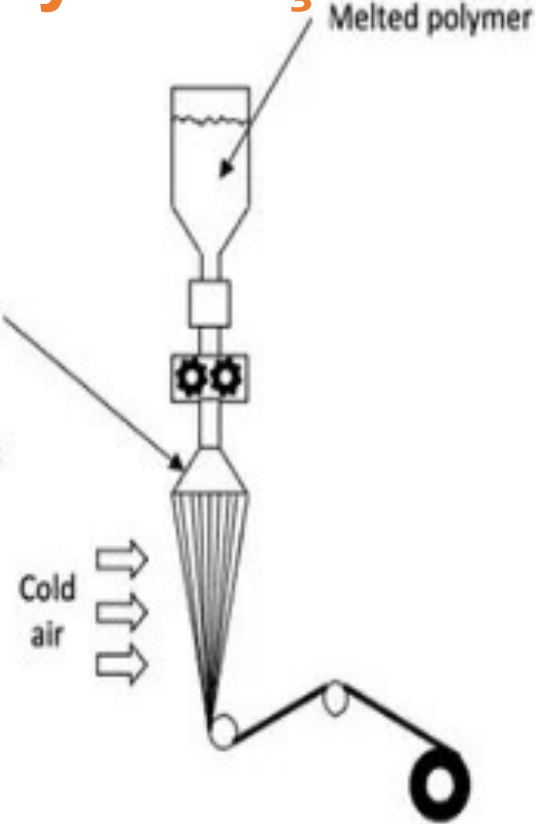

Çekim Yöntemleri



LİF ÜRETİMİ

Bu proje Avrupa Birliği ve Türkiye Cumhuriyeti tarafından finanse edilmektedir

Kuru-jet Yaş Çekim

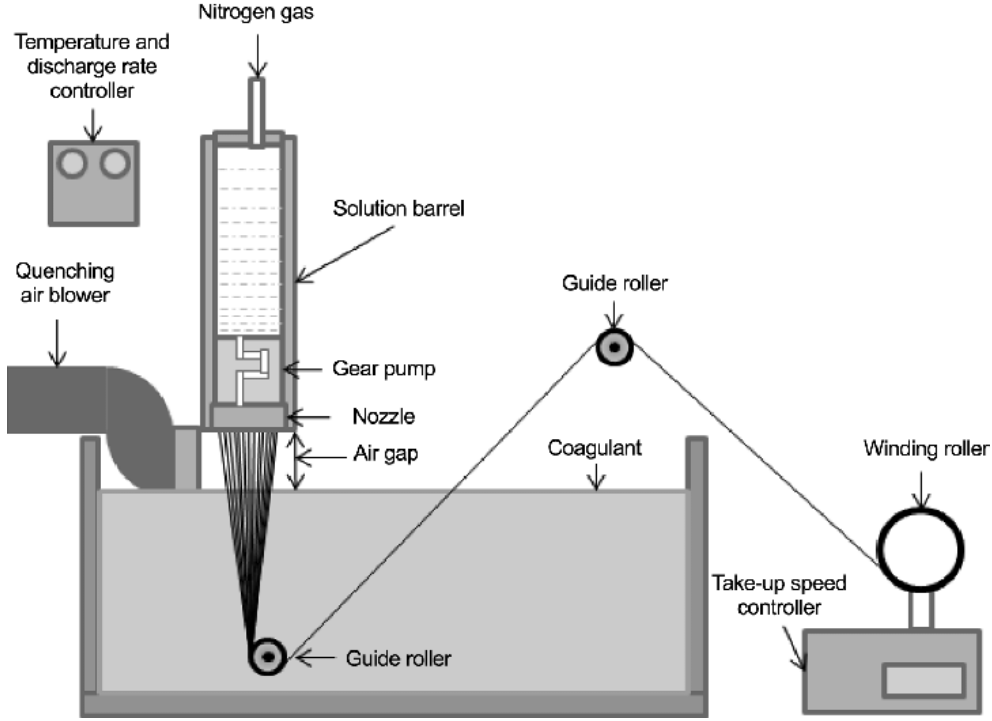

Jel Eğirme

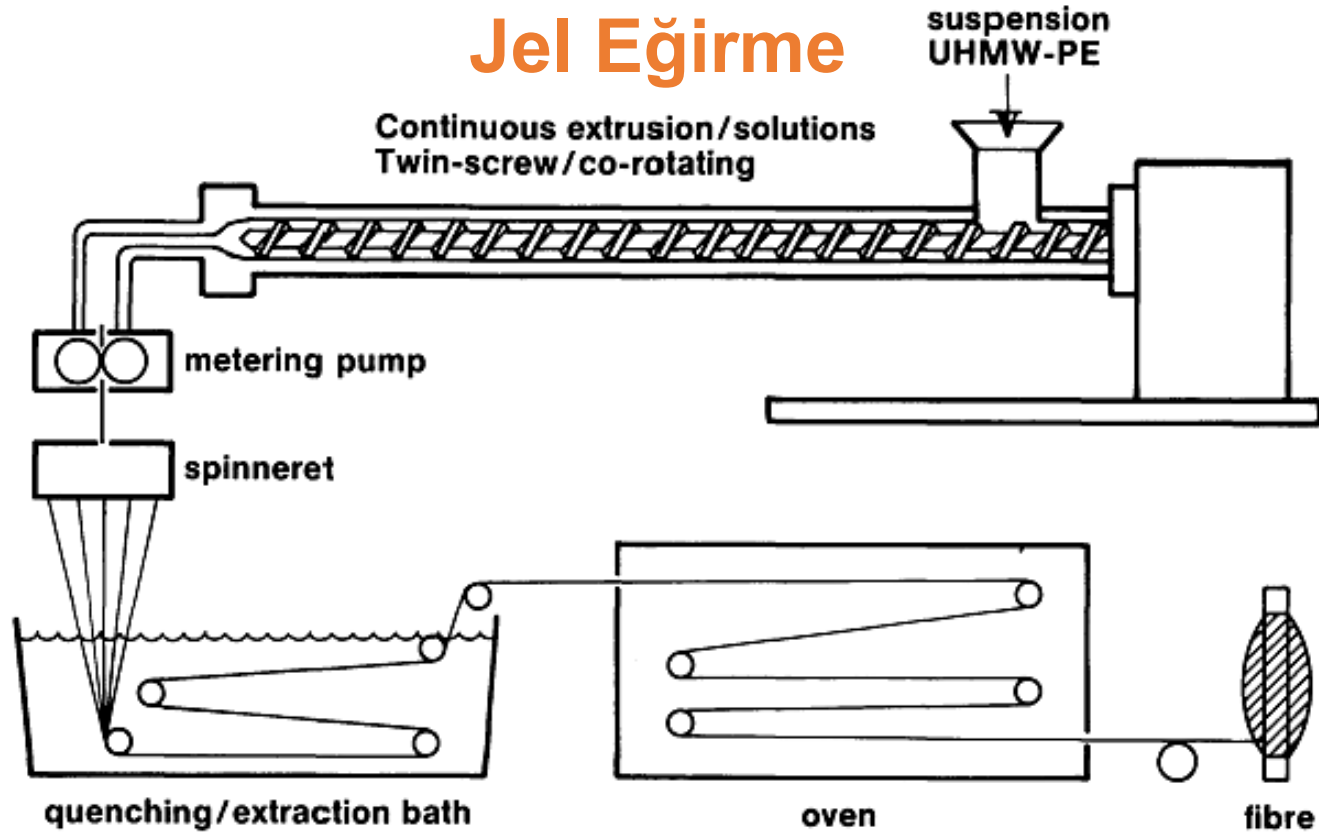

Filament Lifler Eriyikten Eđirme



İPLİK ÜRETİMİ

Bu proje Avrupa Birliđi ve Türkiye Cumhuriyeti tarafından finanse edilmektedir

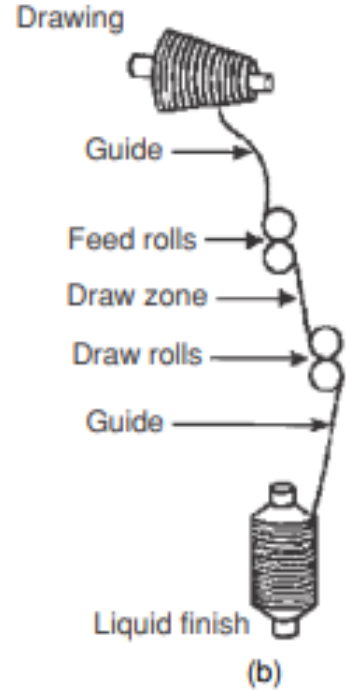
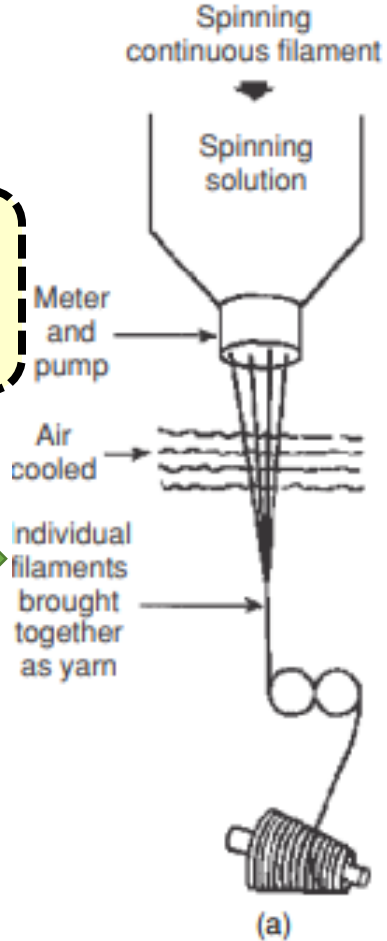

Filament Lifler Tekstüre



Bu proje Avrupa Birliği ve Türkiye Cumhuriyeti tarafından finanse edilmektedir

İPLİK ÜRETİMİ

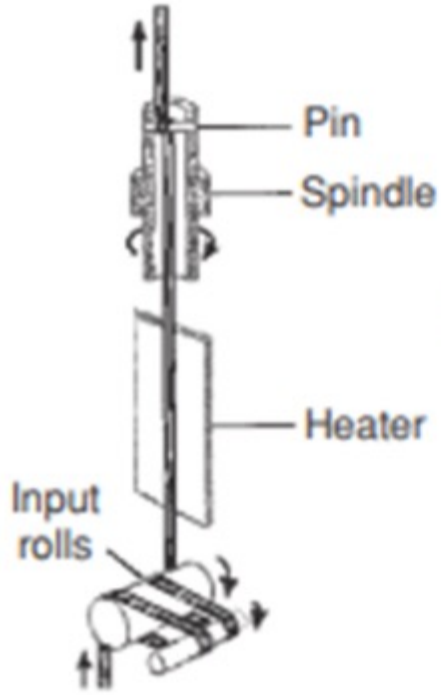

(a)
Yalancı
büküm

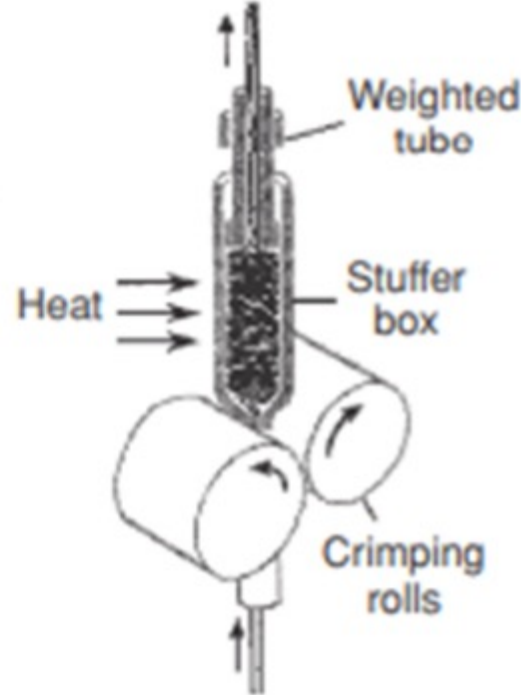

(b)
Hava-jeti



(c)
Doldurma
kutusu

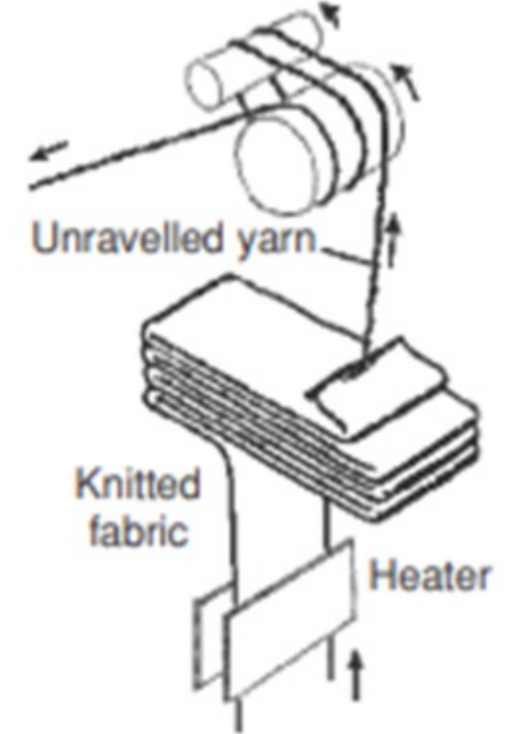

(d)
Örgü-örgü



Filament Lifler Eriyikten Eğirme



Bu proje Avrupa Birliği ve Türkiye Cumhuriyeti tarafından finanse edilmektedir

İPLİK ÜRETİMİ

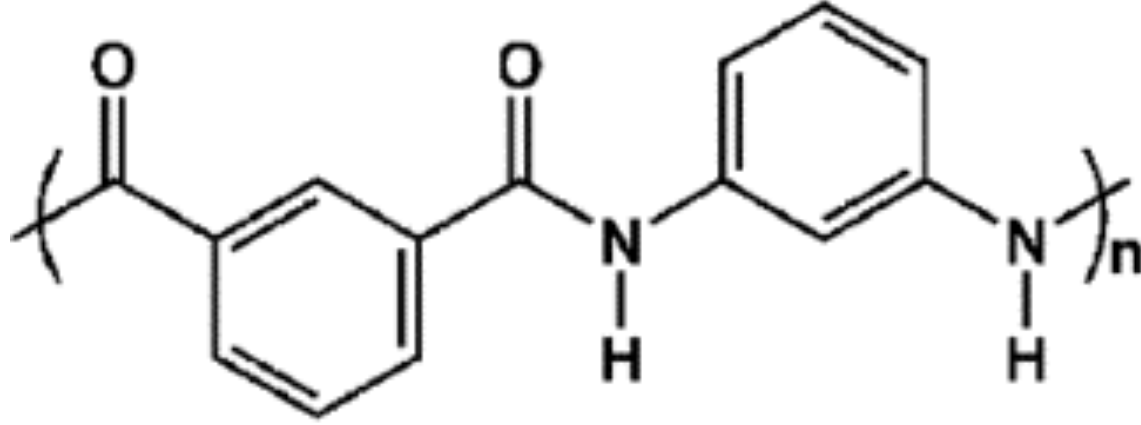

Para bağlantı (1,-4,)

$T_m: >500\text{ }^\circ\text{C}$

$>3500\text{ MPa}$

Nomex®

Meta bağlantı (1,-3,)

$T_m: \sim 350\text{ }^\circ\text{C}$

$>350\text{ MPa}$

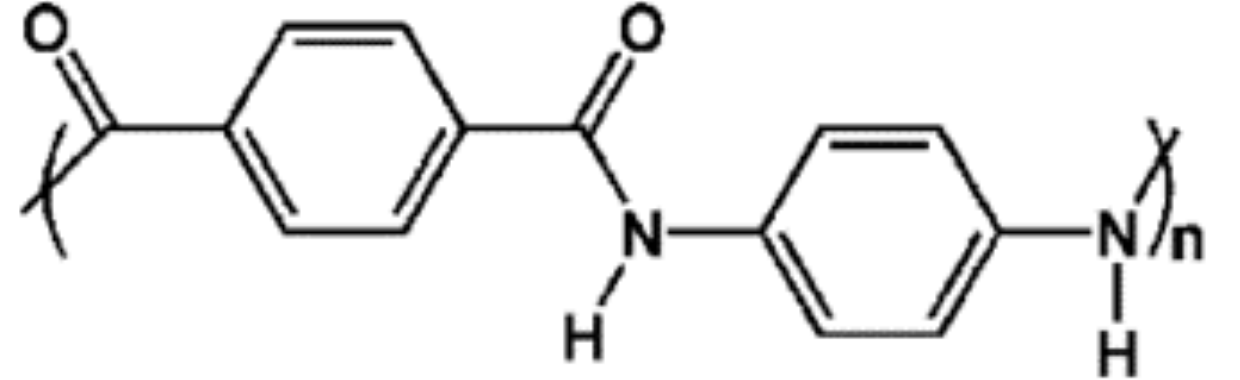

Kevlar®

BUTEXCOMP



Filament Lifler

Cam Lifi Eđirme



İPLİK ÜRETİMİ

Bu proje Avrupa Birliđi ve Türkiye Cumhuriyeti tarafından finanse edilmektedir

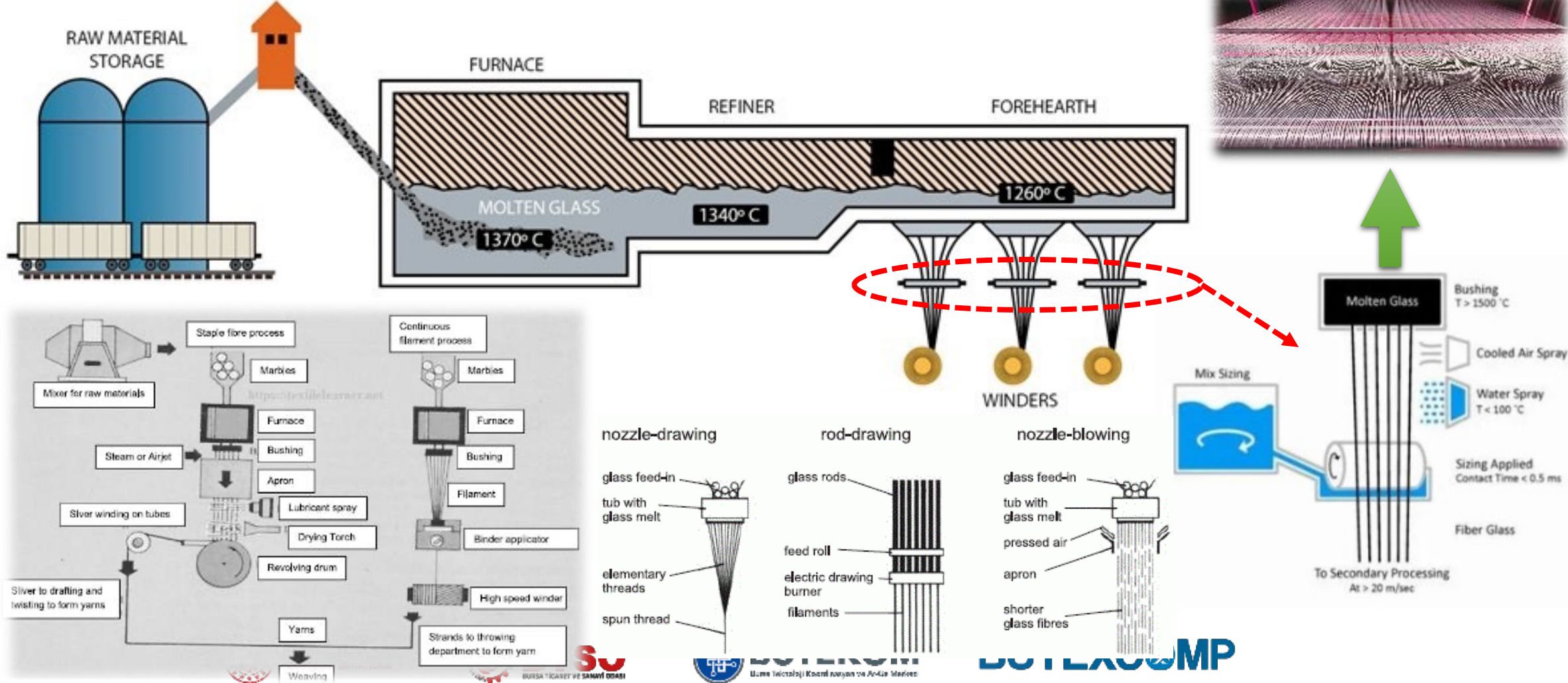

Filament Lifler

Karbon Lifi



İPLİK ÜRETİMİ

Bu proje Avrupa Birliği ve Türkiye Cumhuriyeti tarafından finanse edilmektedir

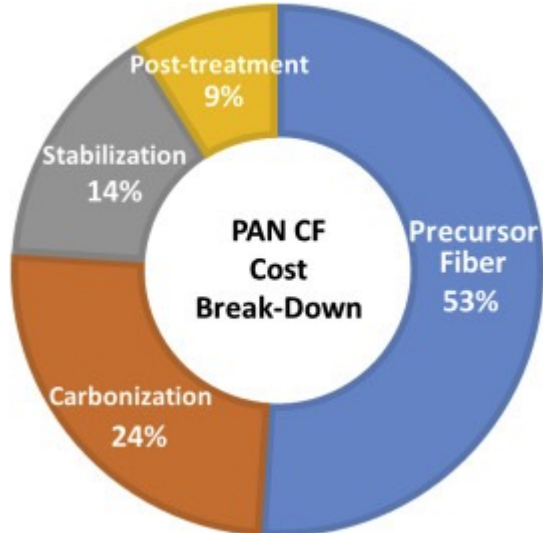
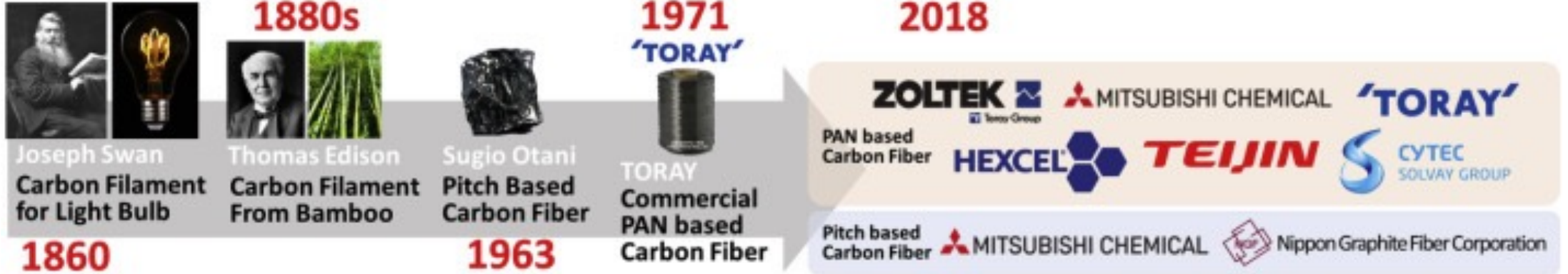

Precursor	Advantages	Disadvantages
Textile PAN	<ul style="list-style-type: none">low energy consumptionhigh volume of productionrelatively high tensile properties	<ul style="list-style-type: none">large cross-section area and linear densitiesuncontrollable oxidation process
Melttable PAN	<ul style="list-style-type: none">relatively high tensile propertiesmelt-spinnable	<ul style="list-style-type: none">require careful oxidation processhigher feedstock price
Lignin	<ul style="list-style-type: none">relatively high tensile propertiesmelt-spinnablelower feedstock pricehigher production rateenvironment-friendly	<ul style="list-style-type: none">higher processing costlower mechanical propertieslower carbon yield
Polyethylene	<ul style="list-style-type: none">melt-spinnablestable precursor costhigher carbon yield	<ul style="list-style-type: none">tedious wet stabilization processlarger capital cost
Pitch	<ul style="list-style-type: none">relatively high tensile propertiesmelt-spinnablelower feedstock pricehigher carbon yieldhigher degree of orientation	<ul style="list-style-type: none">higher processing costlower mechanical properties



Filament Lifler

Karbon Lifi



İPLİK ÜRETİMİ

Bu proje Avrupa Birliği ve Türkiye Cumhuriyeti tarafından finanse edilmektedir

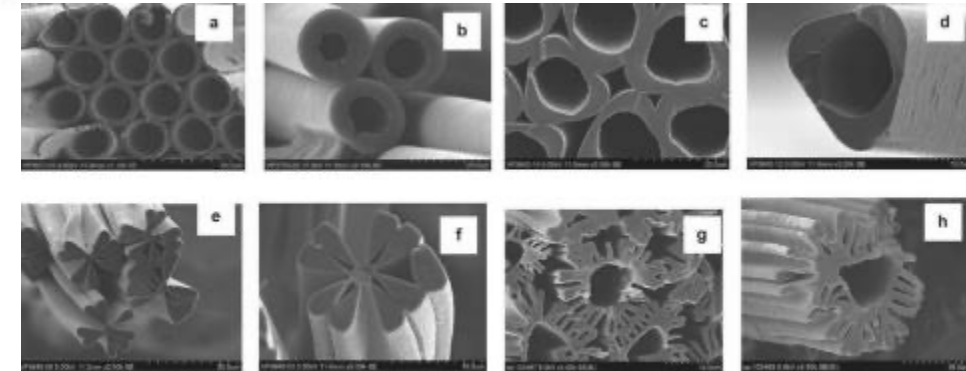
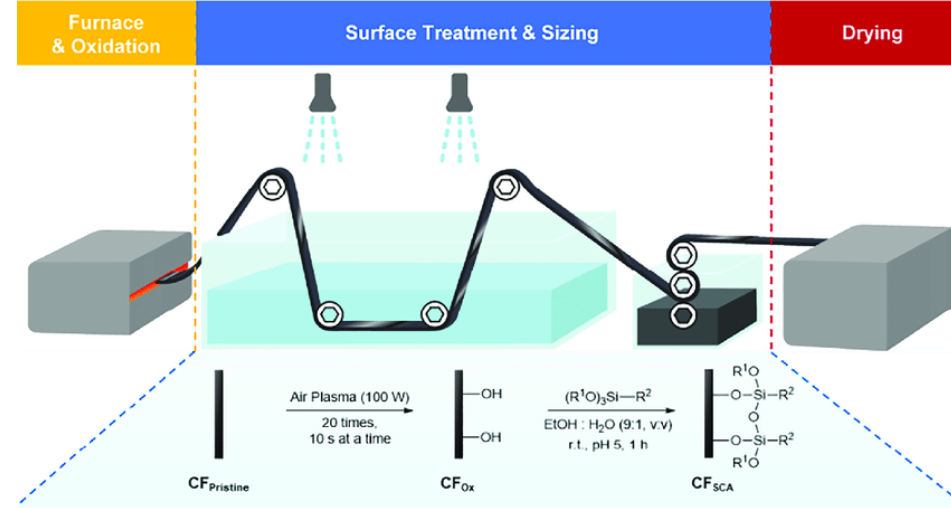
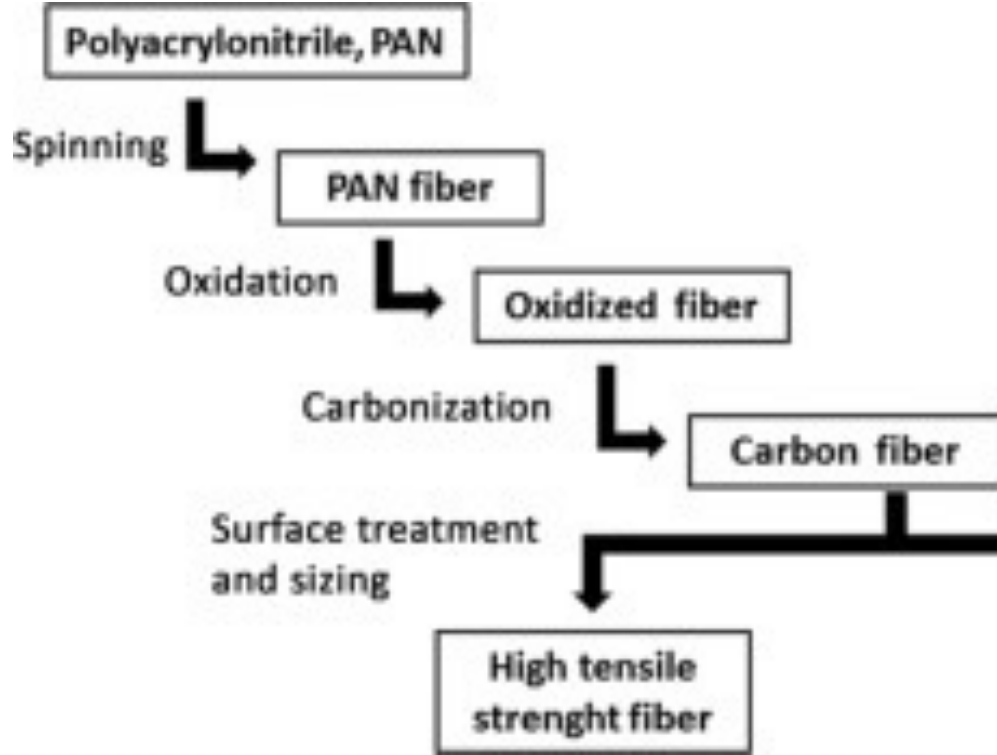

Filament Lifler

Karbon Lifi



İPLİK ÜRETİMİ

Bu proje Avrupa Birliği ve Türkiye Cumhuriyeti tarafından finanse edilmektedir

Current Manufacturing Process
Shindo Method (1959)

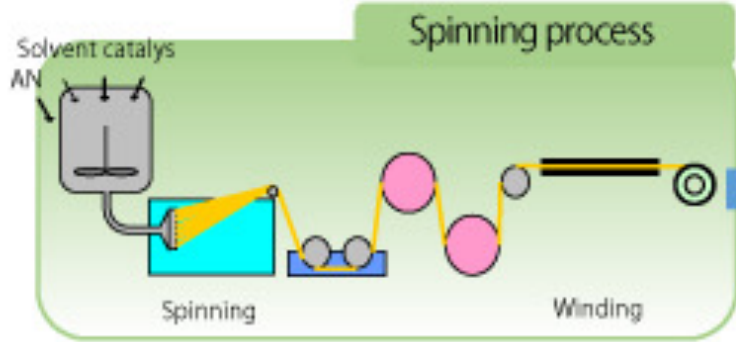

Bottleneck in production

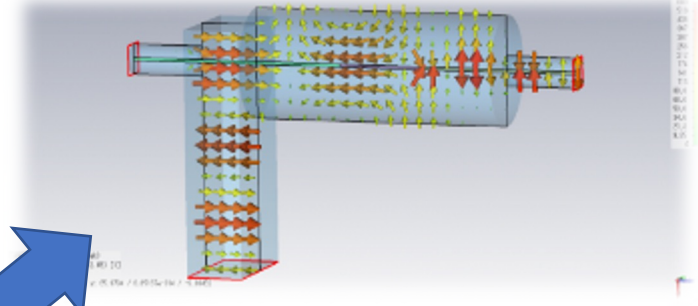
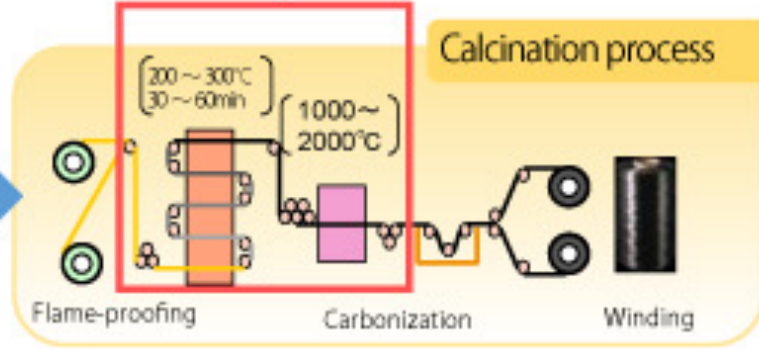

The Novel Carbon Fiber Production Process

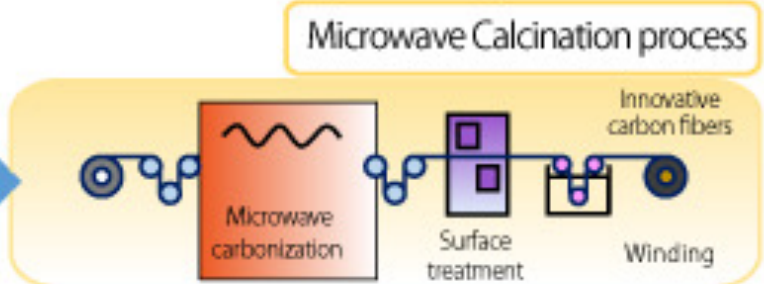
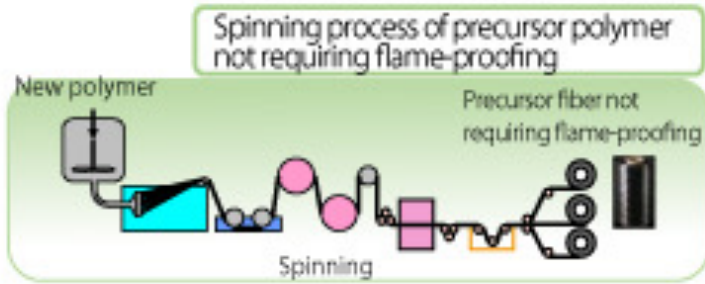

- **Elastik Modül: 240 Gpa**
- **Uzama: 1.5%**
- **Çap: 5 µm**
- **Tow: 48k**



Filament Lifler

Karbon Lifi



Bu proje Avrupa Birliği ve Türkiye Cumhuriyeti tarafından finanse edilmektedir

İPLİK ÜRETİMİ

PAN Carbon Fiber Fabrication Process

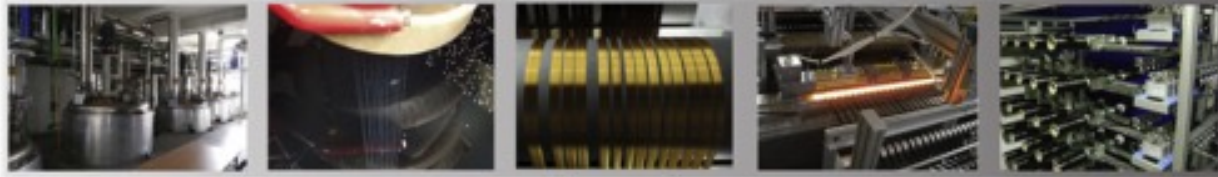

Polymerization \$9.17/kg	Wet Spinning \$4.83/kg	Thermal Stabilization \$4.82/kg	Carbonization \$4/kg	Post-Treatment \$2.88/kg
------------------------------------	----------------------------------	---	--------------------------------	------------------------------------

57-71% ↓

• Textile PAN :
Mass production available

\$4 - \$6/kg

Polymerization	Wet Spinning	Thermal Stabilization	Carbonization	Post-Treatment
-----------------------	---------------------	------------------------------	----------------------	-----------------------



Textile PAN Carbon Fiber Fabrication Process

Total
\$25.7/kg

31-39% ↓

Total
\$15.7
-17.7/kg

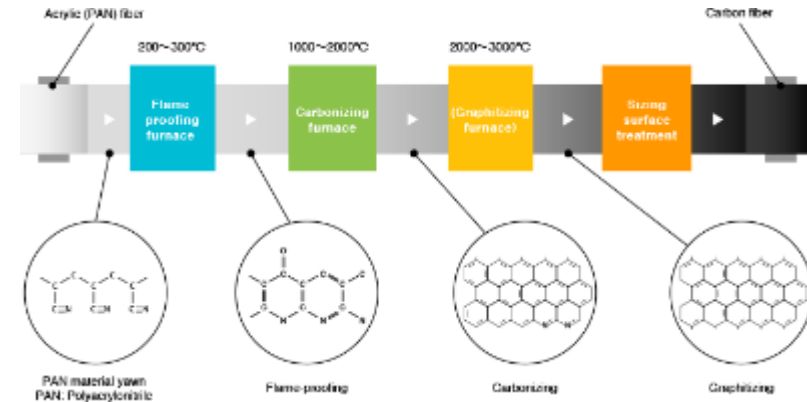
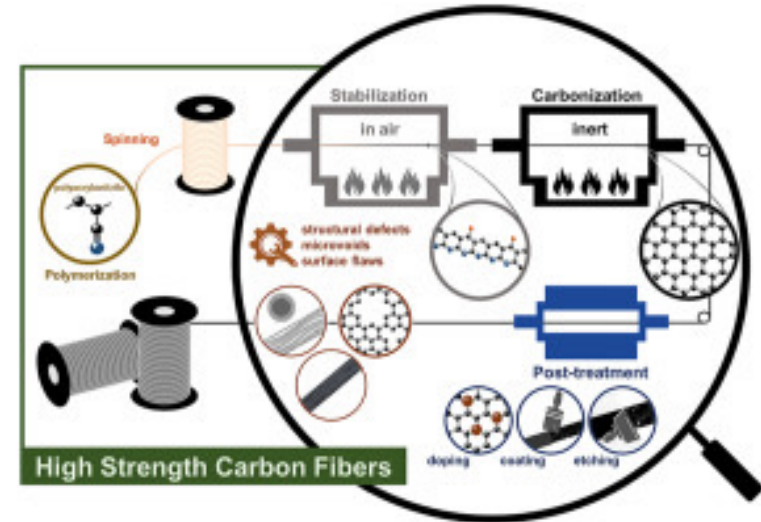

Filament Lifler

Karbon Lifi



İPLİK ÜRETİMİ

Bu proje Avrupa Birliği ve Türkiye Cumhuriyeti tarafından finanse edilmektedir

PAN Carbon Fiber Fabrication Process



Lignin Carbon Fiber Fabrication Process



Filament Lifler

Karbon Lifi



Bu proje Avrupa Birliği ve Türkiye Cumhuriyeti tarafından finanse edilmektedir

İPLİK ÜRETİMİ

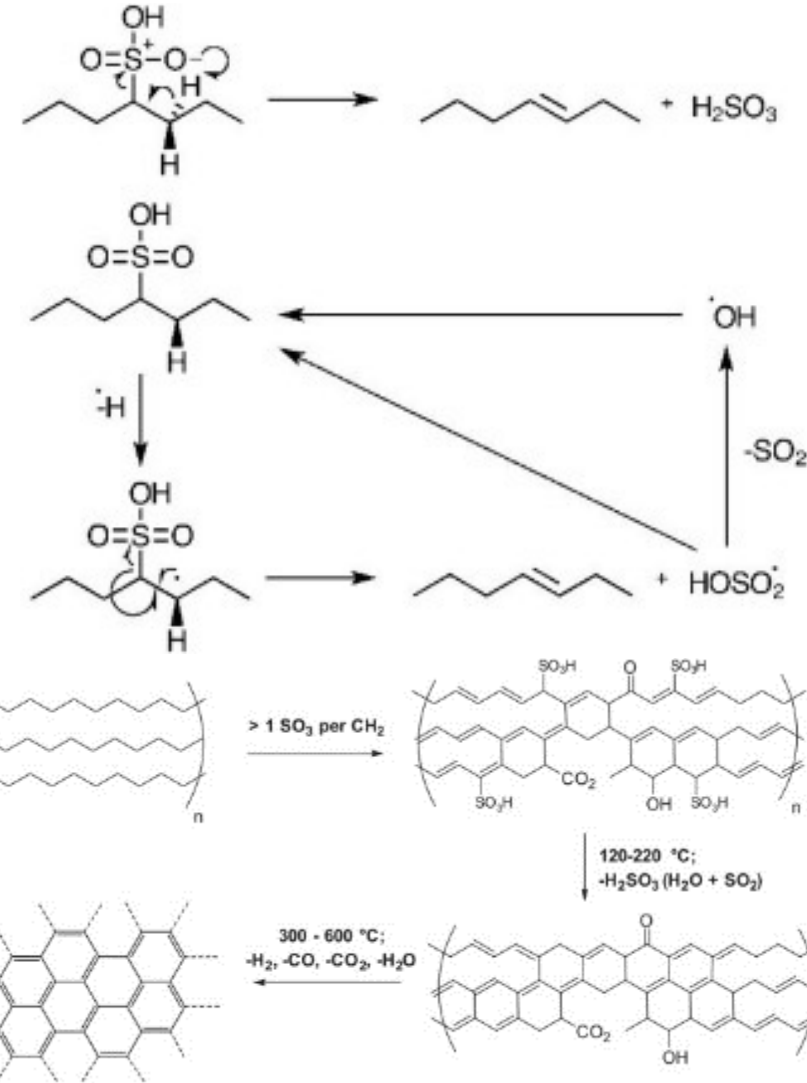

PAN Carbon Fiber Fabrication Process

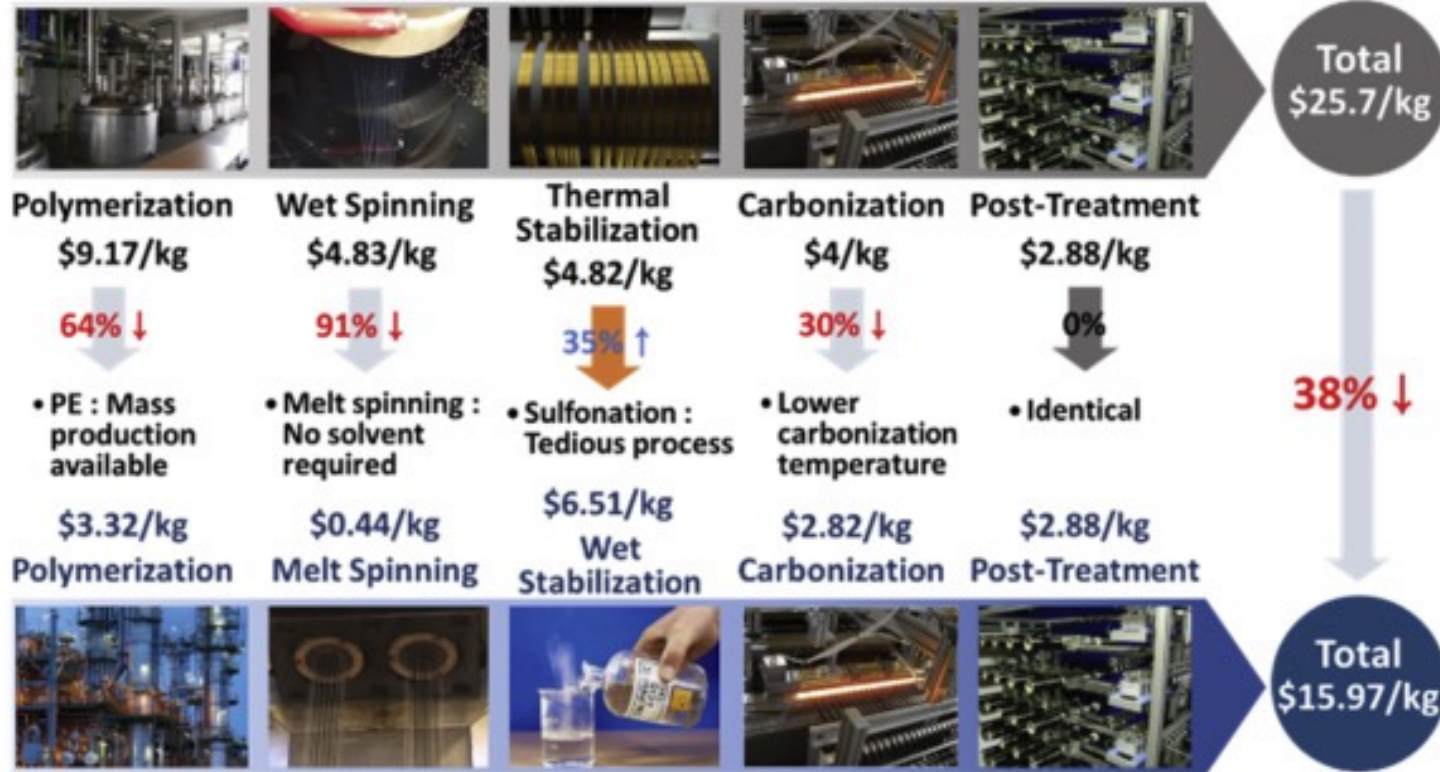

PE Carbon Fiber Fabrication Process



Filament Lifler

UHMWPE



Bu proje Avrupa Birliđi ve Türkiye Cumhuriyeti tarafından finanse edilmektedir

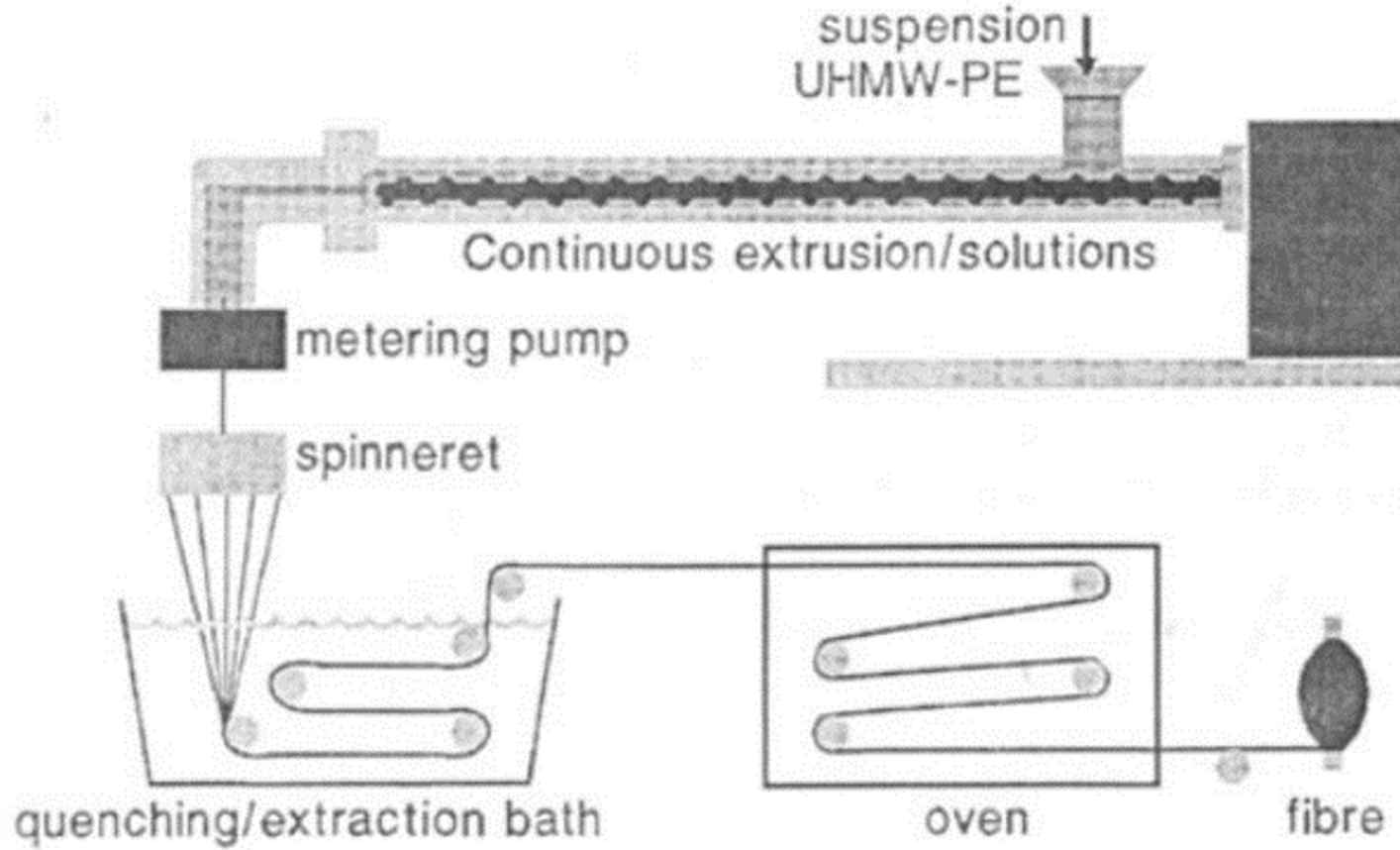

İPLİK ÜRETİMİ

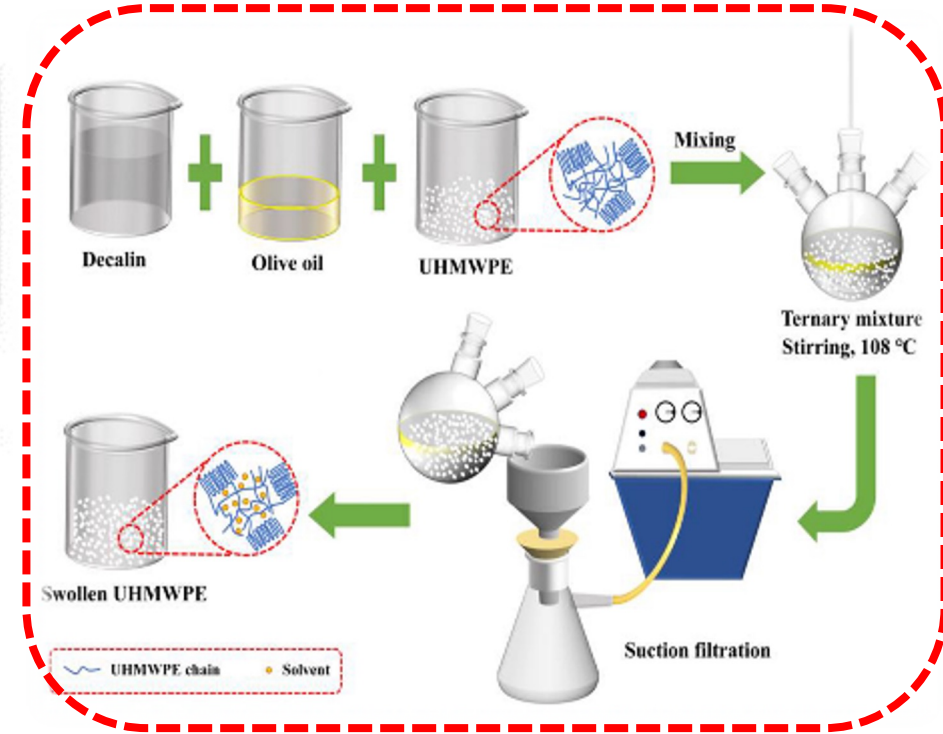

Filament Lifler

UHMWPE Eğirme



İPLİK ÜRETİMİ

Bu proje Avrupa Birliği ve Türkiye Cumhuriyeti tarafından finanse edilmektedir

High Performance Polyethylene Fibers

Company	Type	Mol weight (g/mol)	Cap. (tons/y)	Solvent	Tenacity (50% per minute) (g/den)	Modulus (g/den)	Creep	Filament denier
DYNEEMA	Dyneema SK60	2.0×10^6	~60	volatile	≥ 30	≥ 1000	low	1
	Test grade	2.5×10^6			≥ 35	≥ 1200		1
Allied	Spectra 900	2.5×10^6	>150	paraffin oil	30	1000	medium	9
	Spectra 1000	2.5×10^6			35	1400		5
Mitsui Petrochem	Tekmilon	1.0×10^6	~30	paraffin wax	30	1000	high	10

Dyneema SK60
Crystallinity >70%



Normal PE
Crystallinity <60%



Lamel → Uzatılmış Zincir

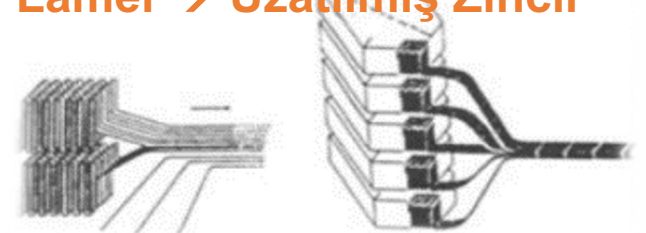

Filament Lifler

UHMWPE Eđirme



İPLİK ÜRETİMİ

Bu proje Avrupa Birliđi ve Türkiye Cumhuriyeti tarafından finanse edilmektedir

TENSILE STRENGTH OF HIGH PERFORMANCE FIBERS

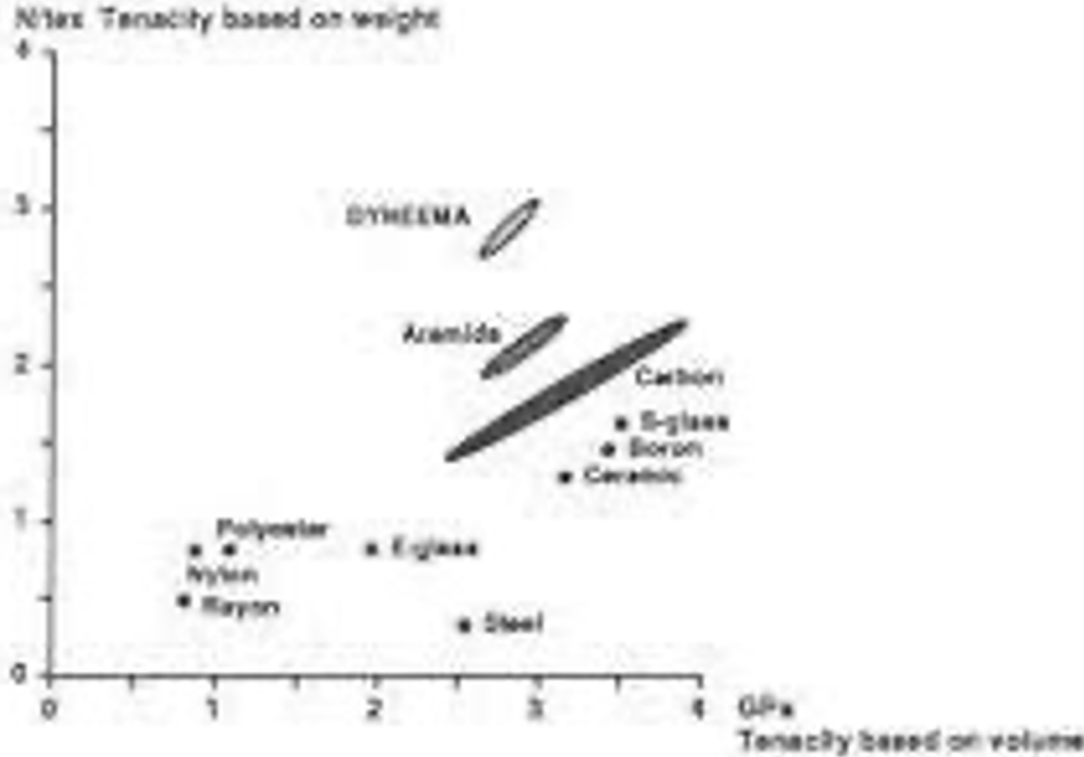

Mechanical properties of polymers

Polymer	Theoretical		Commercial	
	Modulus (N/tex)	Strength (N/tex)	Modulus (N/tex)	Strength (N/tex)
Regular fibers				
PE (polyethylene)	250 - 300	27 - 33	10	0.8
PP (polypropylene)	35 - 50	~ 20	12	0.8
PVA (polyvinylalc.)	180 - 200	~ 21	27	1.0
PAN (polyacrylonitr.)	150	~ 19	17	0.8
PAM-6 (nylon-6)	~200	~ 28	5	0.9
PET (polyester)	80 - 100	~ 23	11	0.9
High performance fibers				
HPPE	250 - 300	27 - 33	90	2.7
Aramids	130	~ 33	100	2.3



Yüksek Performanslı İplikler



İPLİK ÖZELLİKLERİ

Bu proje Avrupa Birliği ve Türkiye Cumhuriyeti tarafından finanse edilmektedir

Yarns	Density (g cm ⁻³)	Strength (GPa)	Modulus (GPa)	Elongation (%)
Aramid – regular	1.44	2.9	60	3.6
Aramid – composite	1.45	2.9	120	1.9
Aramid – ballistic	1.44	3.3	75	3.6
E Glass	2.60	3.5	72	4.8
S Glass	2.50	4.6	86	5.2
Carbon HS	1.78	3.4	240	1.4
Carbon HM	1.85	2.3	390	0.5
Dyneema SK60	0.97	2.7	89	3.5
Dyneema SK65	0.97	3.0	95	3.6
Dyneema SK66	0.97	3.2	99	3.7
Steel	7.86	1.77	200	1.1



Yüksek Performanslı Lifler



LİF ÖZELLİKLERİ

Bu proje Avrupa Birliği ve Türkiye Cumhuriyeti tarafından finanse edilmektedir

Fibre	Density (g cm ⁻³)	Tenacity (mN tex ⁻¹)	Elongation (%)	Regain (%)
PTFE	2.1	0.9–2.0	19–140	0
PBI	1.43	2.6–3.0	25–30	15
PBO	1.54	42	2.5–3.5	0.6–2.0

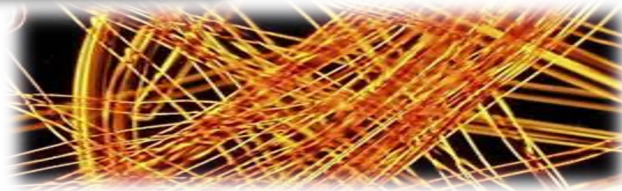
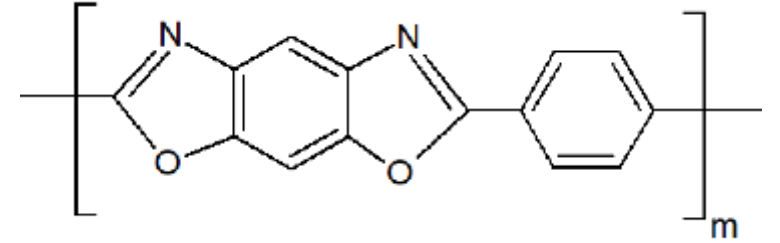
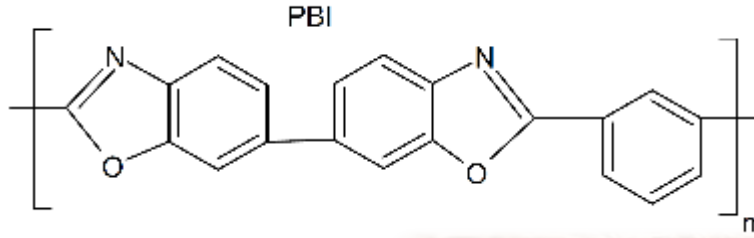
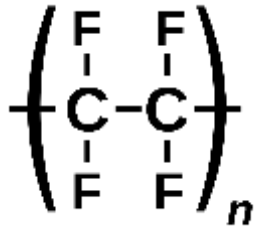



Bu proje Avrupa Birliđi ve Türkiye Cumhuriyeti tarafından finanse edilmektedir

4. Bölüm

DOKUMA KUMAŞ ÜRETİMİ



Bez Ayağı Plain



KUMAŞ ÜRETİMİ

Bu proje Avrupa Birliği ve Türkiye Cumhuriyeti tarafından finanse edilmektedir

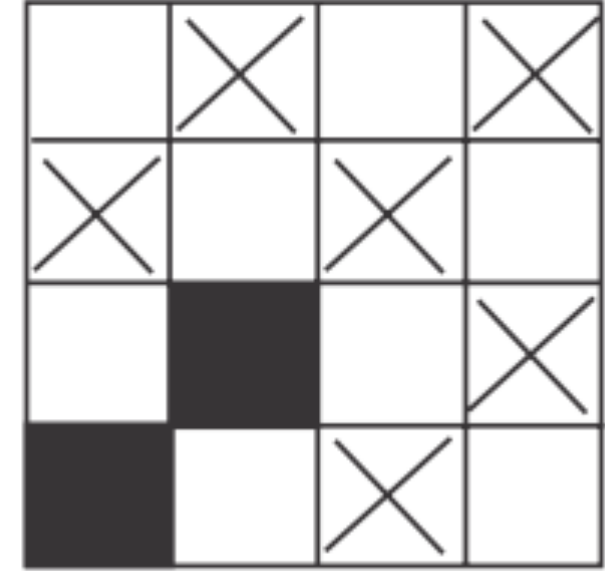
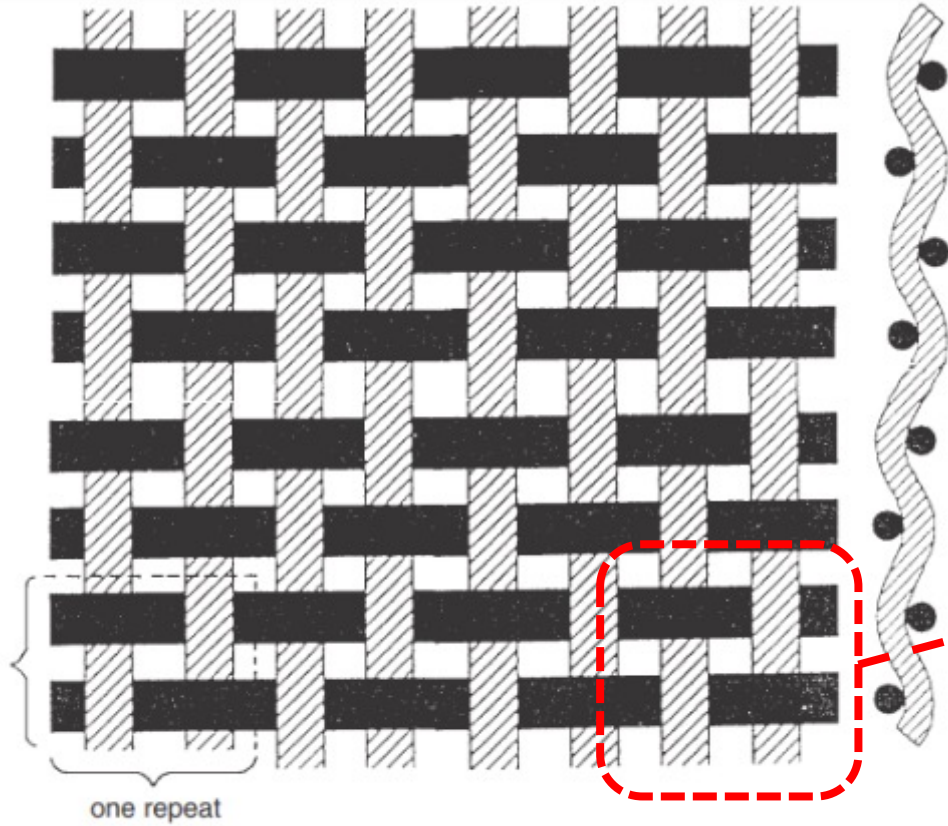

Bez Ayađı Gramaj – Örtme Faktörü



KUMAŞ ÜRETİMİ

Bu proje Avrupa Birliđi ve Türkiye Cumhuriyeti tarafından finanse edilmektedir



Bez Ayağı

Çözgü yüzlü kumaşlar



KUMAŞ ÜRETİMİ

Bu proje Avrupa Birliği ve Türkiye Cumhuriyeti tarafından finanse edilmektedir

Plan View

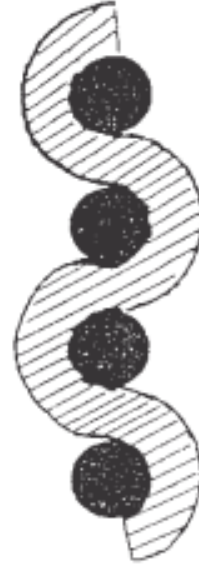
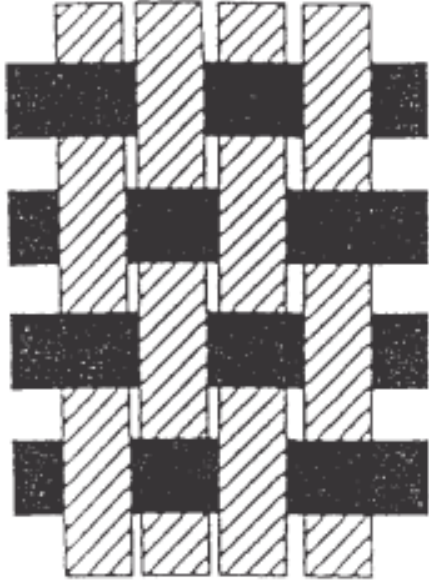

Cross-sections

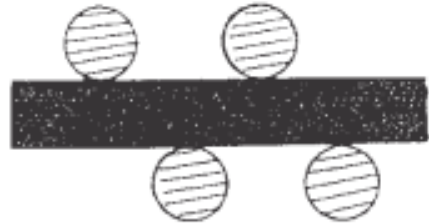

Rib

Çözgü vs Atkı



Bu proje Avrupa Birliği ve Türkiye Cumhuriyeti tarafından finanse edilmektedir

KUMAŞ ÜRETİMİ

2/2 çözgü ribi

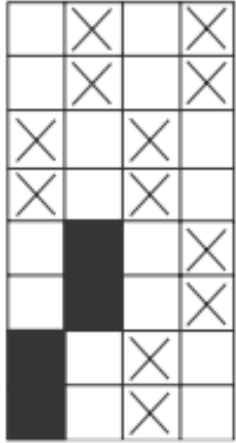

(a)

2/2 atkı ribi

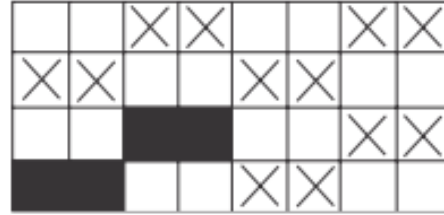

(b)

3/1 çözgü ribi



(c)

4/4 çözgü ribi



(d)



Mat Plain



Bu proje Avrupa Birliği ve Türkiye Cumhuriyeti tarafından finanse edilmektedir

KUMAŞ ÜRETİMİ

2/2 mat kumaş

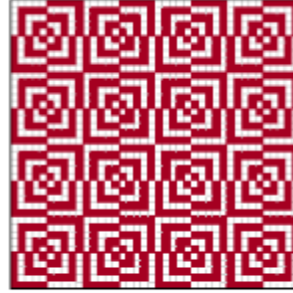

$\frac{5}{5}(5)$ fancy matt

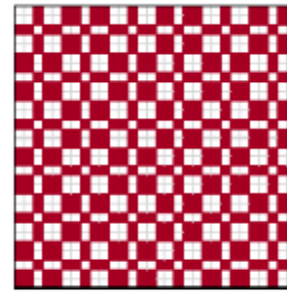

$\frac{5}{5}(5)$ fancy matt

4/2 mat kumaş

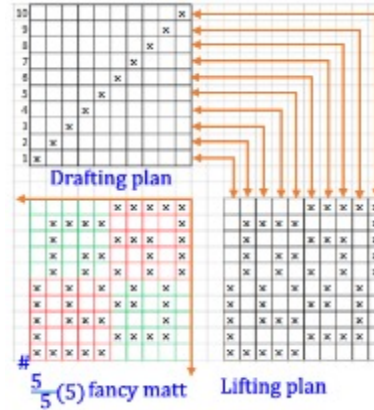
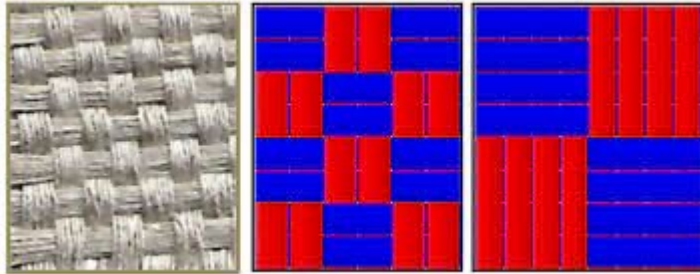
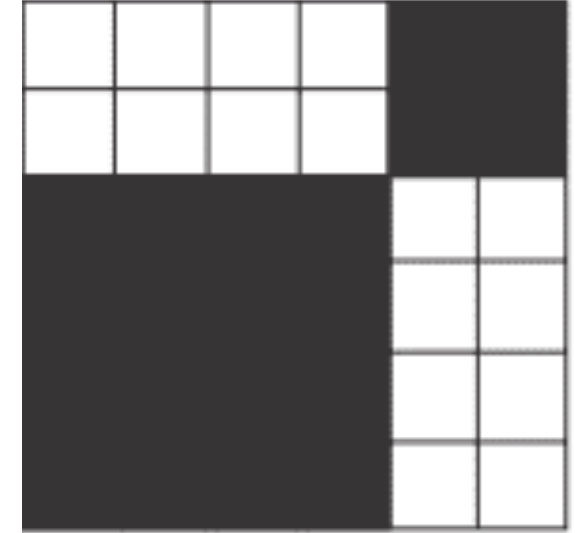

Dimi

3 x 3 Dimi



Bu proje Avrupa Birliđi ve Türkiye Cumhuriyeti tarafından finanse edilmektedir

KUMAŞ ÜRETİMİ

2/1 dimi (Z)



2/1 dimi (Z)



2/1 dimi (S)



1/2 dimi (Z)



1/2 dimi (S)

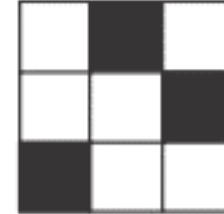

Dimi

4 x 4 ve 5 x 5 Dimi



Bu proje Avrupa Birliği ve Türkiye Cumhuriyeti tarafından finanse edilmektedir

KUMAŞ ÜRETİMİ

4 x 4
Dimi

3/1 dimi (Z)



2/2 dimi (Z)



1/3 dimi (Z)

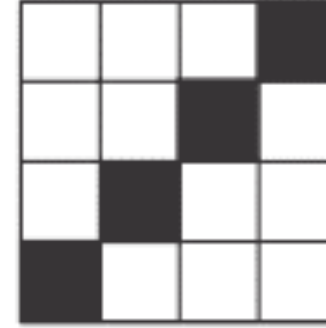

5 x 5
Dimi

4/1 dimi (Z)



1/4 dimi (Z)

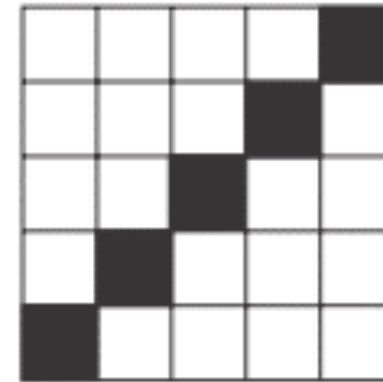

Saten

Atkı vs Çözüğü Sateni



KUMAŞ ÜRETİMİ

Bu proje Avrupa Birliği ve Türkiye Cumhuriyeti tarafından finanse edilmektedir

2 atlamalı

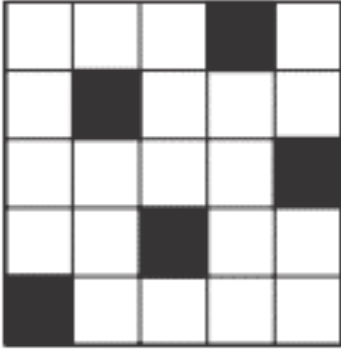

3 atlamalı

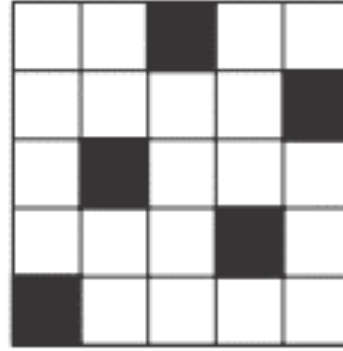

3 atlamalı

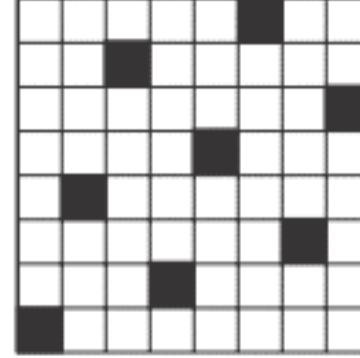

5 atlamalı

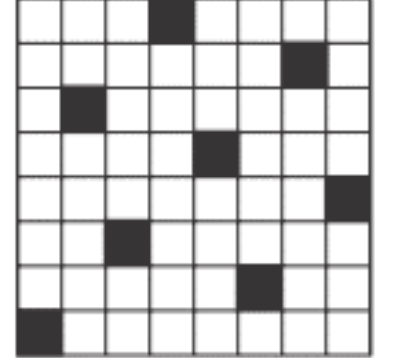

Atkı
Sateni

Çözüğü
Sateni



5 atlamalı



Leno

Atkı vs Çözüğü Sateni



KUMAŞ ÜRETİMİ

Bu proje Avrupa Birliği ve Türkiye Cumhuriyeti tarafından finanse edilmektedir

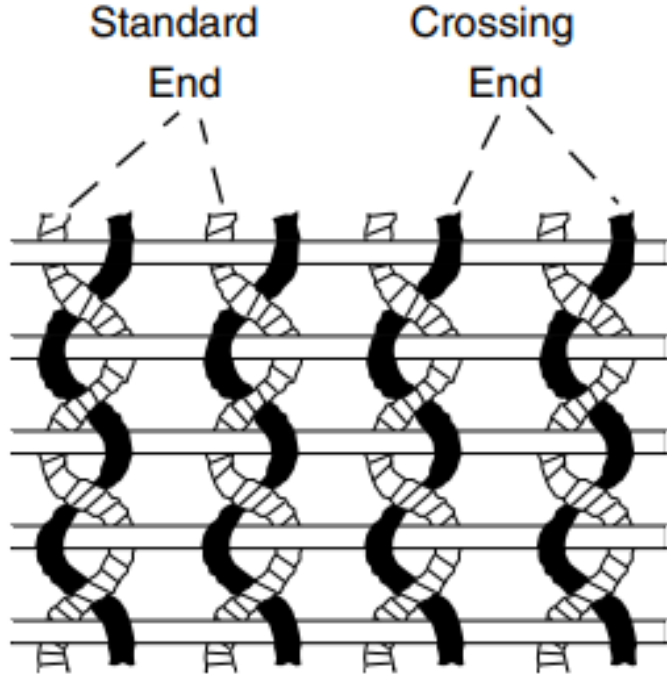

Plan View



Cross-section

Farklı uzunluklarda standart ve çapraz çözgü

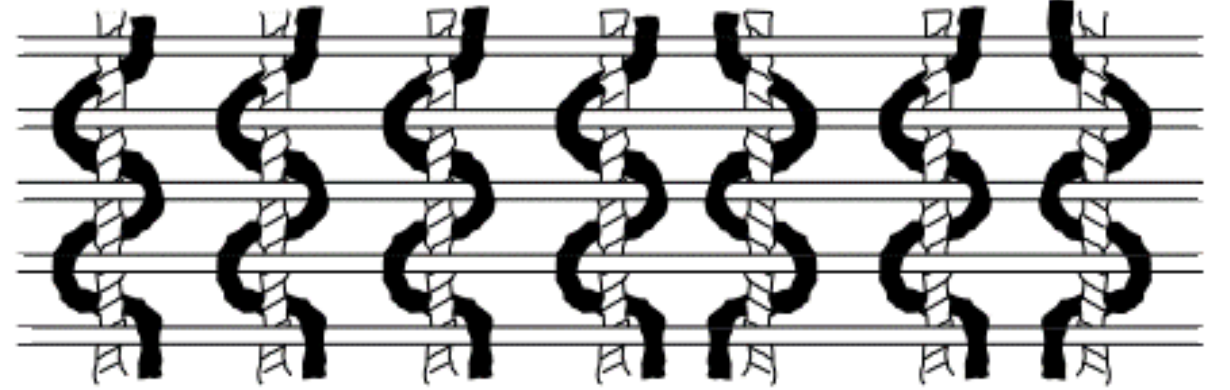

Eşit uzunluklarda standart ve çapraz çözgü



3 Eksenli Dokuma

Temel vs Sepet



KUMAŞ ÜRETİMİ

Bu proje Avrupa Birliği ve Türkiye Cumhuriyeti tarafından finanse edilmektedir

Temel

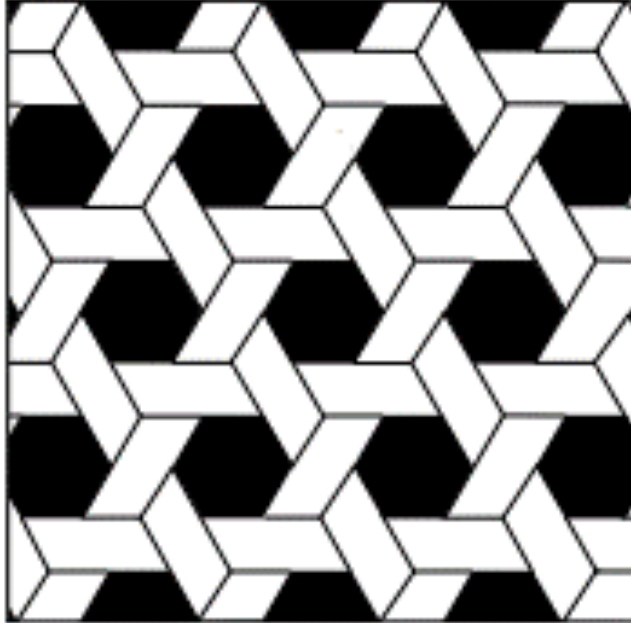

Sepet

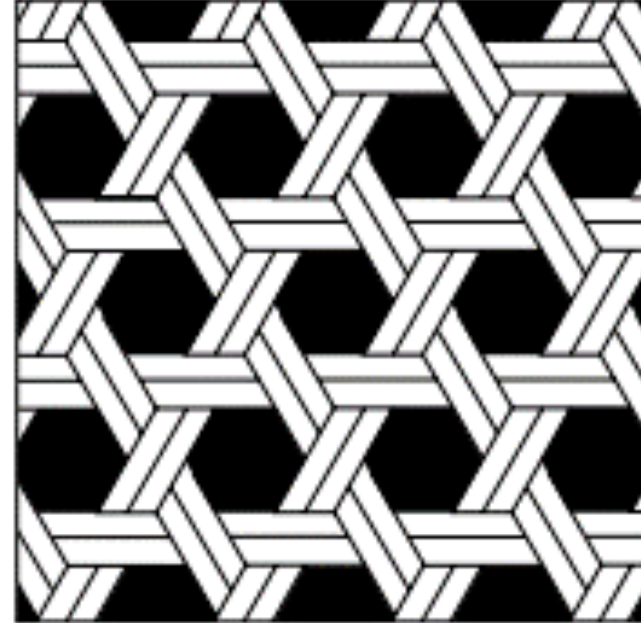

Kenar Toka



Bu proje Avrupa Birliđi ve Türkiye Cumhuriyeti tarafından finanse edilmektedir

KUMAŞ ÜRETİMİ

Leno

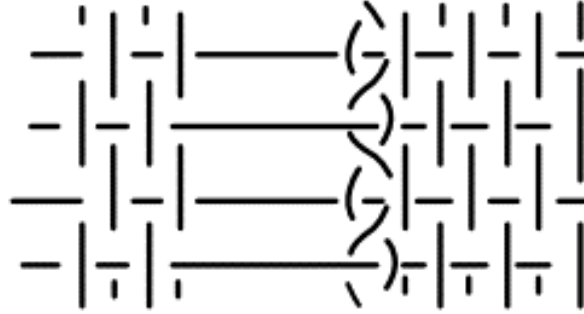

Sıkışık

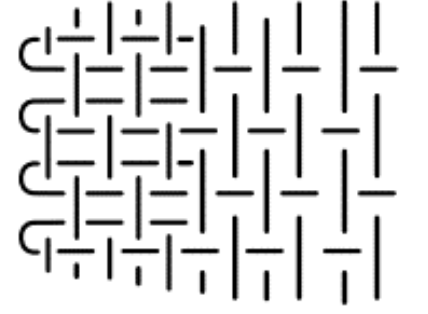

Toka

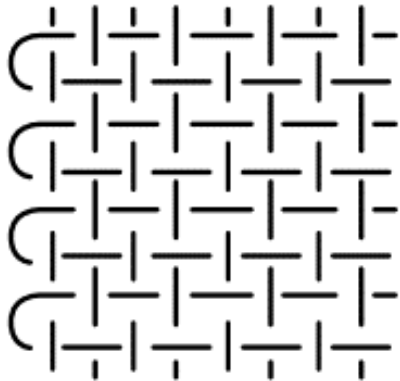

Helis

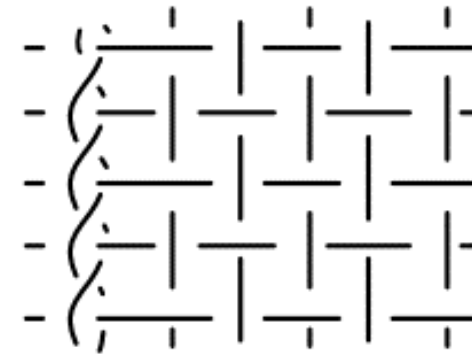

Dokuma Kumaş Özellikleri



KUMAŞ ÜRETİMİ

Bu proje Avrupa Birliği ve Türkiye Cumhuriyeti tarafından finanse edilmektedir

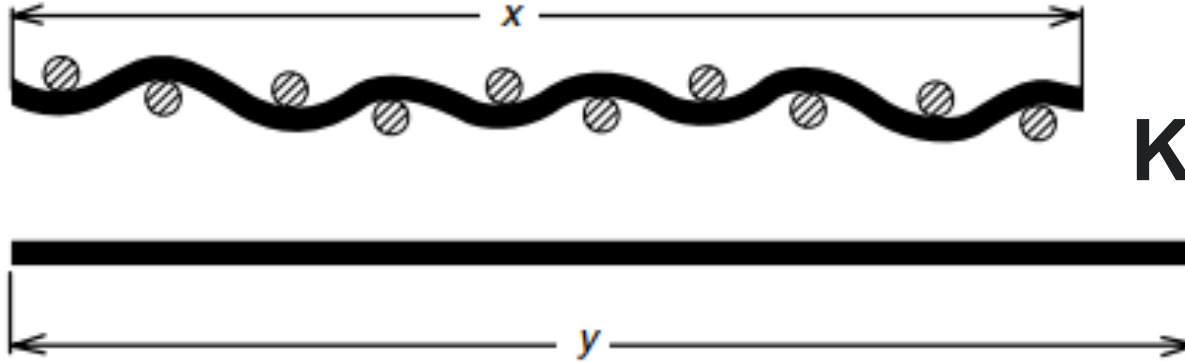

$$\text{Kıvrım\%} = \frac{y-x}{x} * 100$$

Cloth	Threads per cm		Linear density		Cover factor		Cloth weight ^a (g/m ²)	Thickness ^b (mm)
	n_1	n_2	N_1	N_2	K_1	K_2		
A	24	24	25	25	12.0	12.0	130	0.28
B	12	12	100	100	12.0	12.0	260	0.56
C	6	6	400	400	12.0	12.0	520	1.12



Dokuma Kumaş Özellikleri



Bu proje Avrupa Birliği ve Türkiye Cumhuriyeti tarafından finanse edilmektedir

KUMAŞ ÜRETİMİ

$$\text{warp cover } (k_{\text{warp}}) = \frac{\text{EPI}}{\sqrt{N e_{\text{warp}}}}$$

$$\text{weft cover } (k_{\text{weft}}) = \frac{\text{PPI}}{\sqrt{N e_{\text{weft}}}}$$

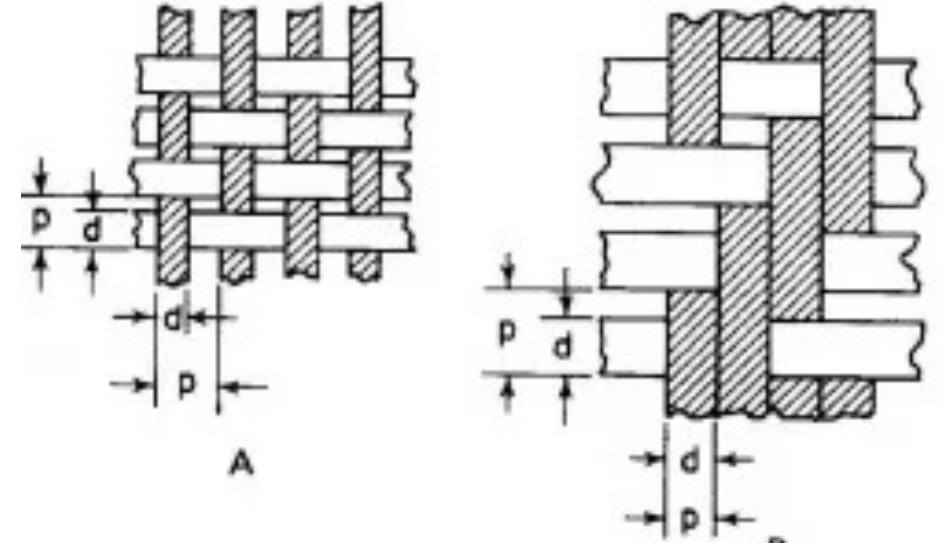

$$\text{clothe cover } (K_{\text{clothe}}) = (k_{\text{warp}} + k_{\text{weft}}) - \left(\frac{k_{\text{warp}} \times k_{\text{weft}}}{28} \right)$$



Dokuma

Çalışma Prensibi



DOKUMA MAKİNESİ

Bu proje Avrupa Birliği ve Türkiye Cumhuriyeti tarafından finanse edilmektedir

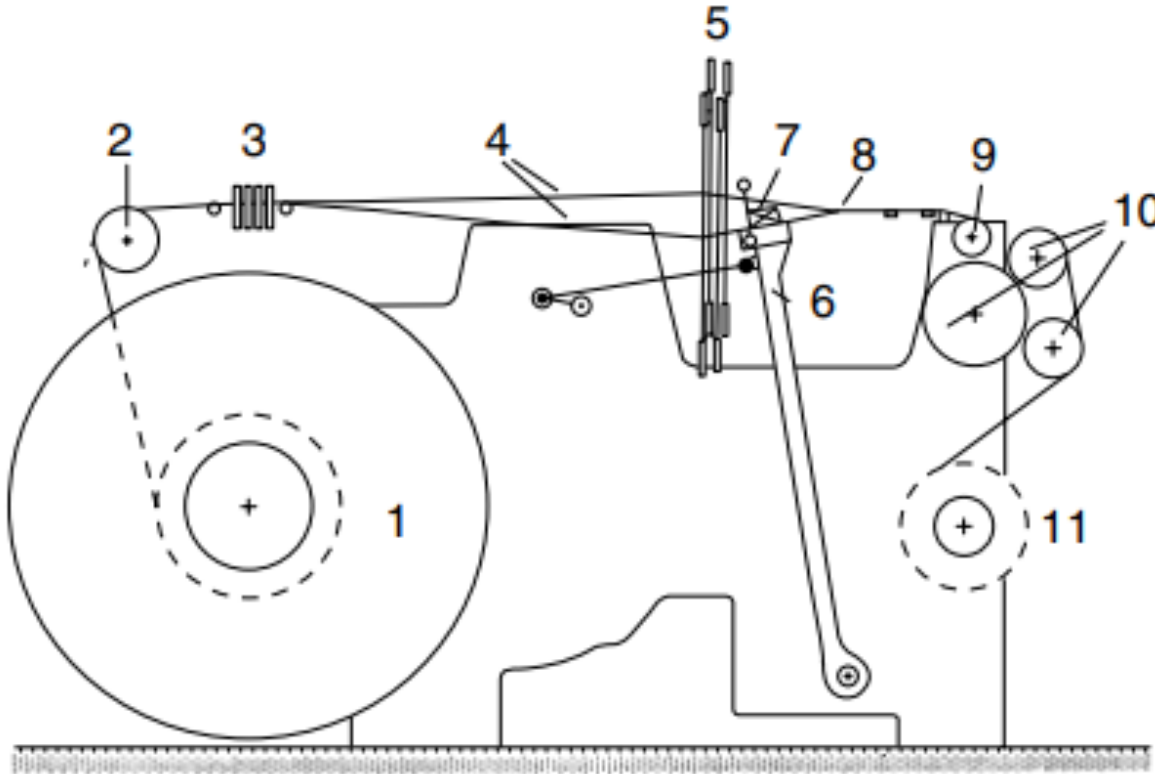

- 1: çözgü ipliğini tutan levendi
- 2: arka dayanak
- 3: çözgü durdurma;
- 4: ağızlık;
- 5: çerçeveler;
- 6: mekik taşıyan tarak;
- 7: iğ taşıyan mekik;
- 8: kumaşın oluşturulduğu yer;
- 9: kumaşı yönlendirmek için ön dayanak;
- 10: sarma hareketi;
- 11: kumaşın kumaş silindrine sarılması



Sınıflandırma



DOKUMA MAKİNESİ

Bu proje Avrupa Birliği ve Türkiye Cumhuriyeti tarafından finanse edilmektedir

Single-phase weaving machines

Machines with shuttles (looms):

Hand operated (hand looms)

Non-automatic power looms (weft supply in shuttle changed by hand)

Automatic weaving machines

- shuttle changing rotary batteries, stack batteries, box loaders or pirn winder mounted on machine (Unifil)
- pirn changing

Shuttleless weaving machines:

Projectile

Rapier

- rigid rapier(s) single rapier, single rapier working bilaterally or two rapiers operating from opposite sides of machine
- telescopic
- flexible

Jet machines

- air (with or without relay nozzles)
- liquid (generally water)

Multiphase weaving machines

Wave shed machines:

Weft carriers move in straight path

Circular weaving machines (weft carriers travel in circular path)

Parallel shed machines (rapier or air jet)



Ağızlık Açma Çok Fazlı



DOKUMA MAKİNESİ

Bu proje Avrupa Birliği ve Türkiye Cumhuriyeti tarafından finanse edilmektedir

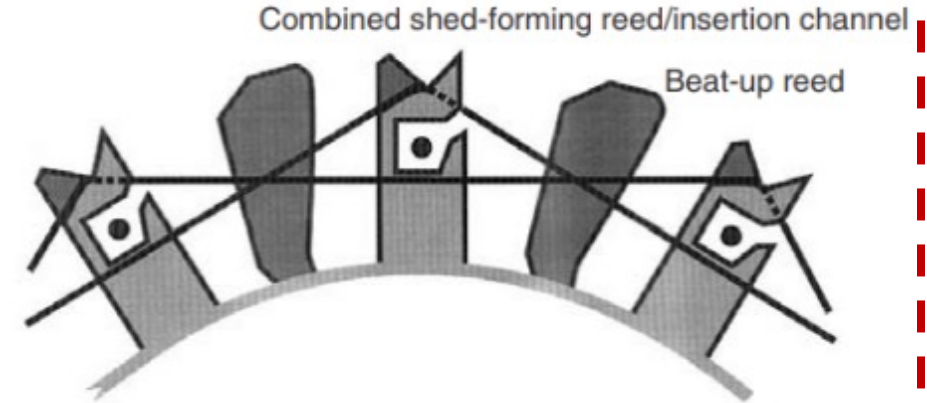
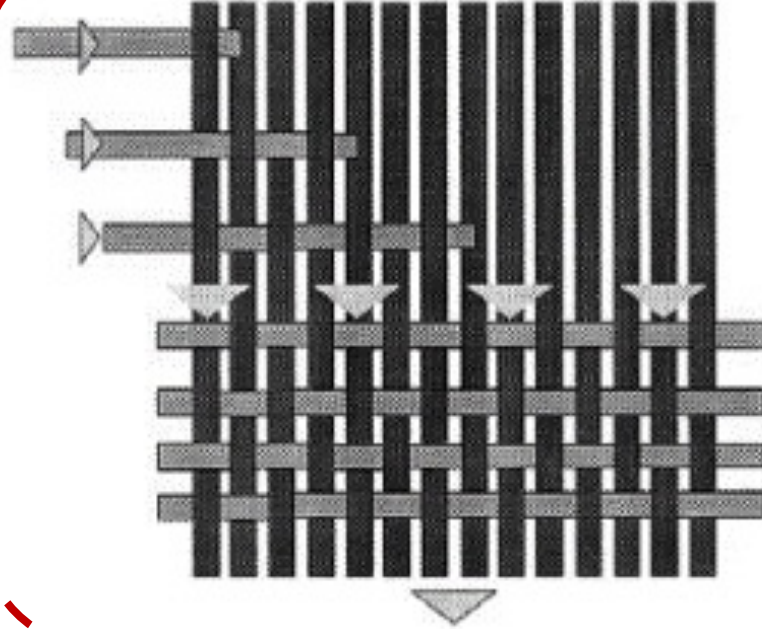
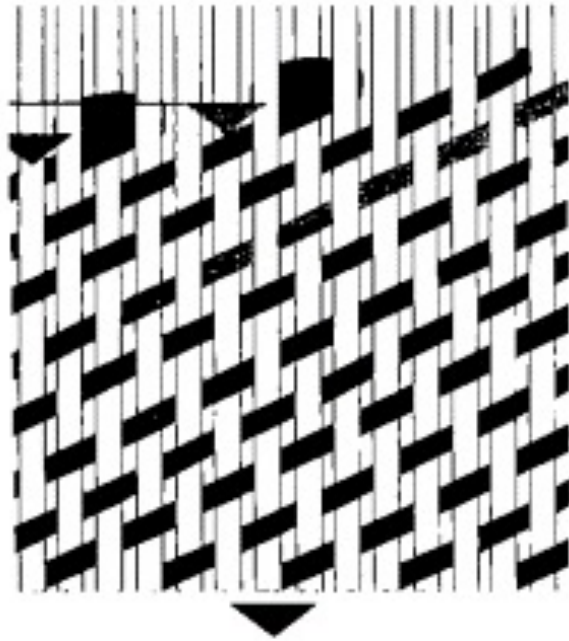

Ağızlık Açma Dairesel Dokuma Makineleri



DOKUMA MAKİNESİ

Bu proje Avrupa Birliği ve Türkiye Cumhuriyeti tarafından finanse edilmektedir

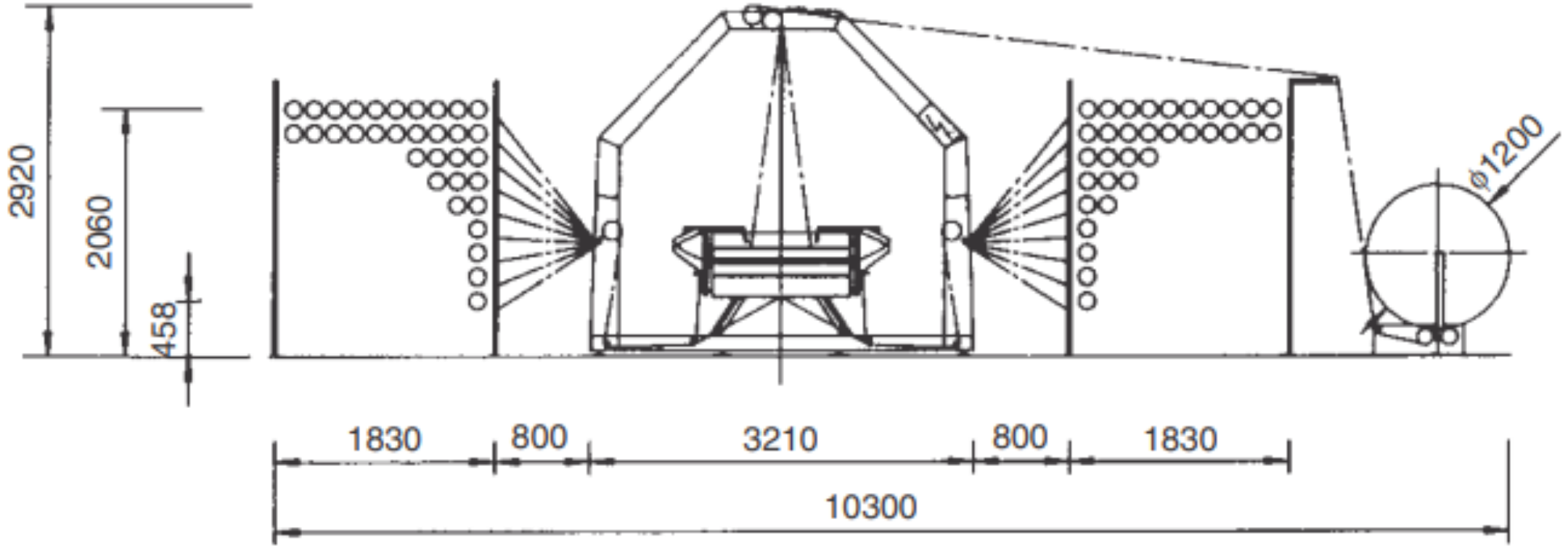

Mekikli Dokuma



DOKUMA MAKİNESİ

Bu proje Avrupa Birliđi ve Türkiye Cumhuriyeti tarafından finanse edilmektedir

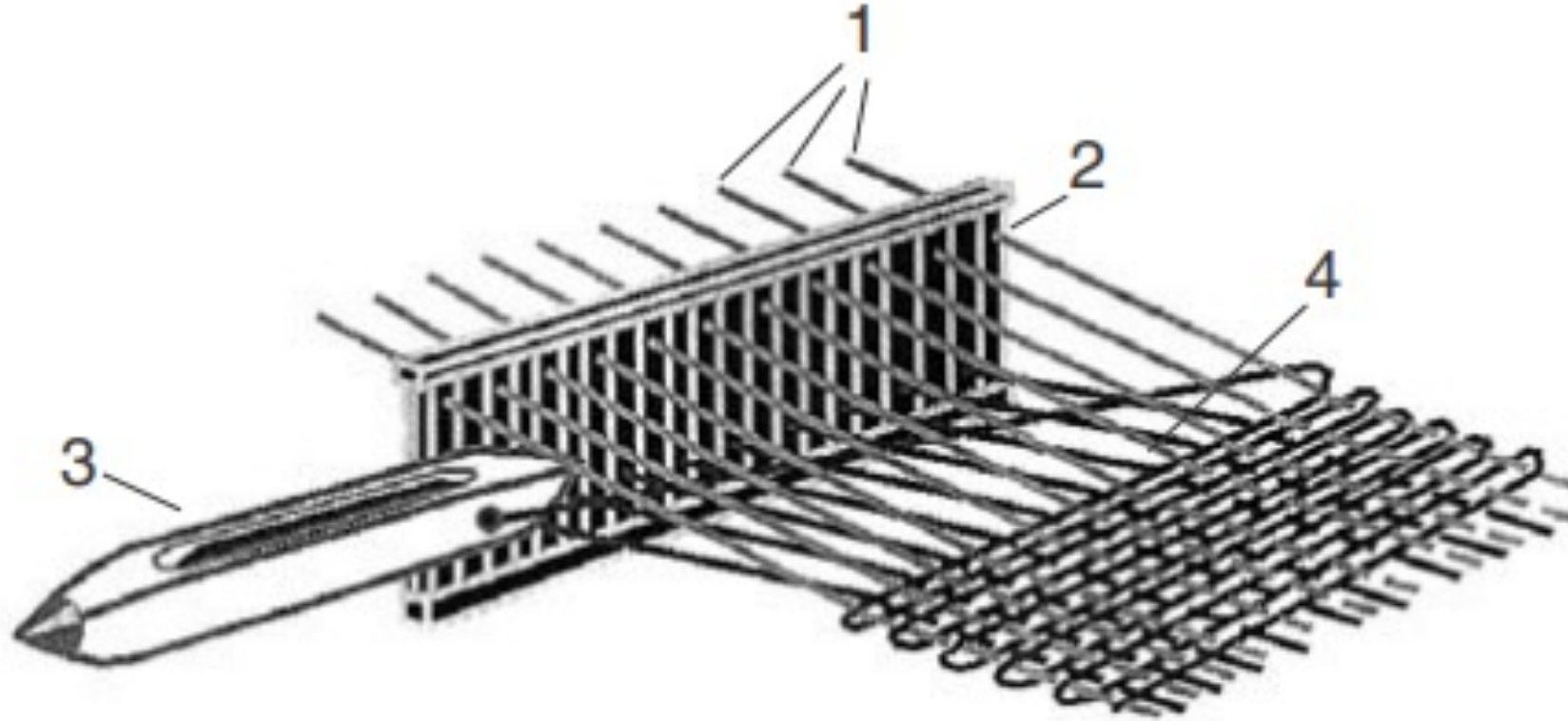

- 1: Çözgü iplikleri
- 2: Çerçeve
- 3: İğ taşıyan mekik
- 4: Kumaş çizgisi



Mekiksiz Dokuma



Bu proje Avrupa Birliđi ve Türkiye Cumhuriyeti tarafından finanse edilmektedir

DOKUMA MAKİNESİ

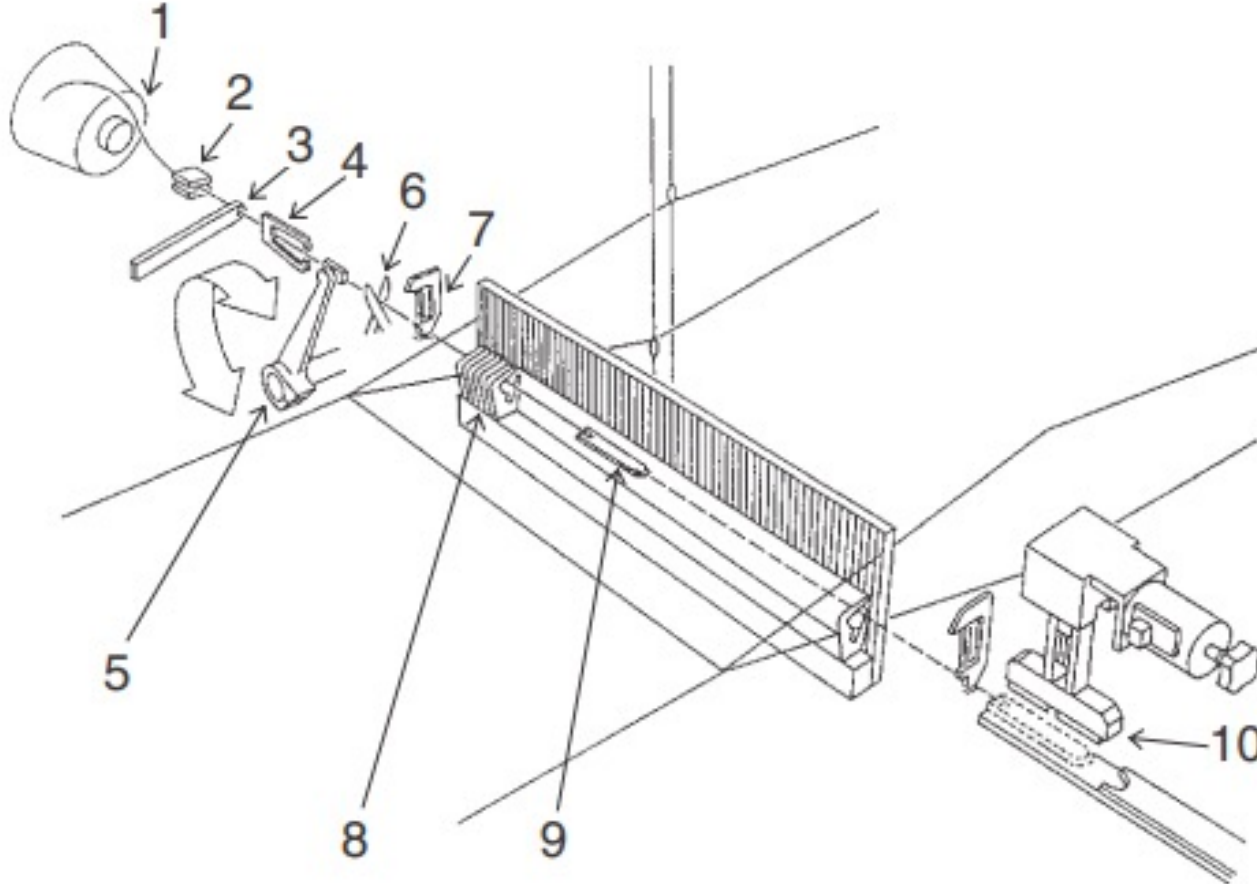

- 1: Atkı (bobin üzerinde)
- 2: iplik freni
- 3: atkı gerdirici
- 4: atkı sunucusu
- 5: torsiyon çubuđu
- 6: atkı kesici (makas)
- 7: tutucu
- 8: kılavuz
- 9: projektıl
- 10: projektıl freni



Hava Jetli Dokuma



DOKUMA MAKİNESİ

Bu proje Avrupa Birliği ve Türkiye Cumhuriyeti tarafından finanse edilmektedir

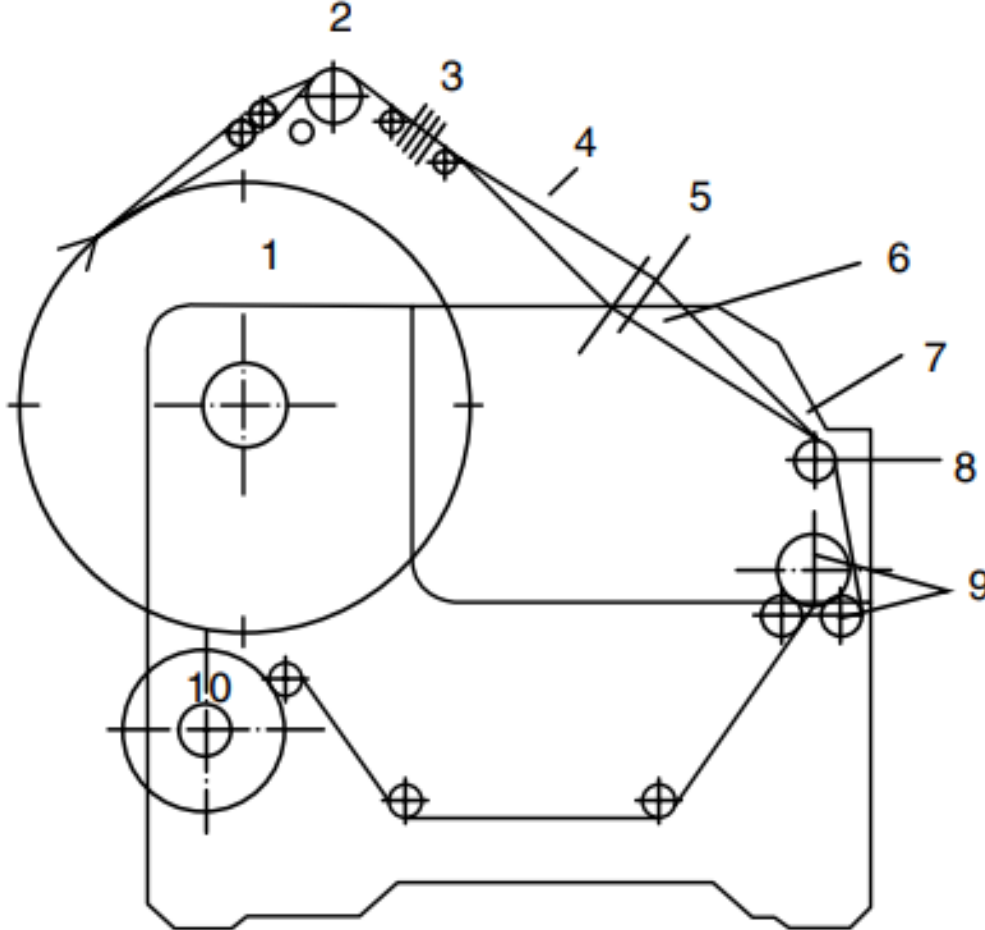

- 1: çözü levendi
- 2: arka dayanak
- 3: çözü durdurma
- 4: ağızlık
- 5: çerçeve
- 6: atkı yerleştirme alanı
- 7: kumaş çizgisi
- 8: ön dayanak
- 9: sarma silindiri
- 10: kumaş silindiri



Hava Jetli Dokuma



DOKUMA MAKİNESİ

Bu proje Avrupa Birliđi ve Türkiye Cumhuriyeti tarafından finanse edilmektedir

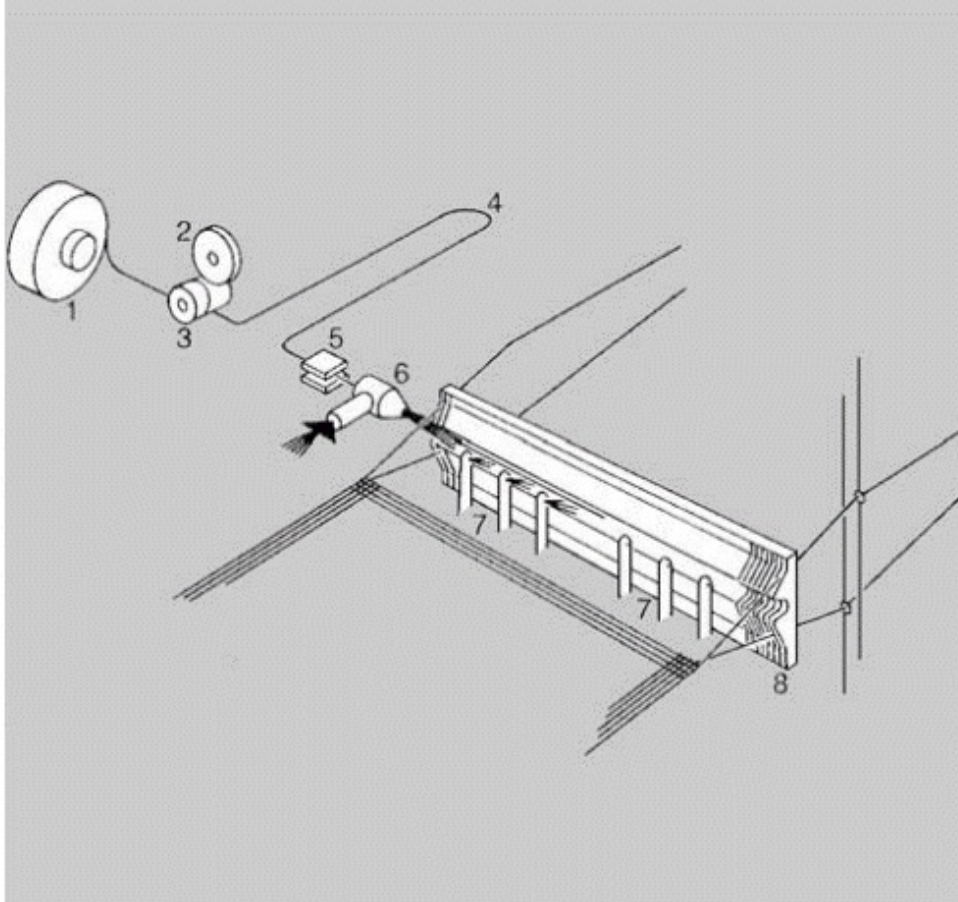

- 1: atkı bobini
- 2: ölçüm diski
- 3: silindirler
- 4: depolama tüpü
- 5: kelepçe
- 6: ana nozul
- 7: röle nozulları
- 8: tünelli çerçeve





Bu proje Avrupa Birliđi ve Türkiye Cumhuriyeti tarafından finanse edilmektedir

5. Bölüm

ÖRME KUMAŞLAR



Sınıflandırma



ÖRME KUMAŞLAR

Bu proje Avrupa Birliği ve Türkiye Cumhuriyeti tarafından finanse edilmektedir

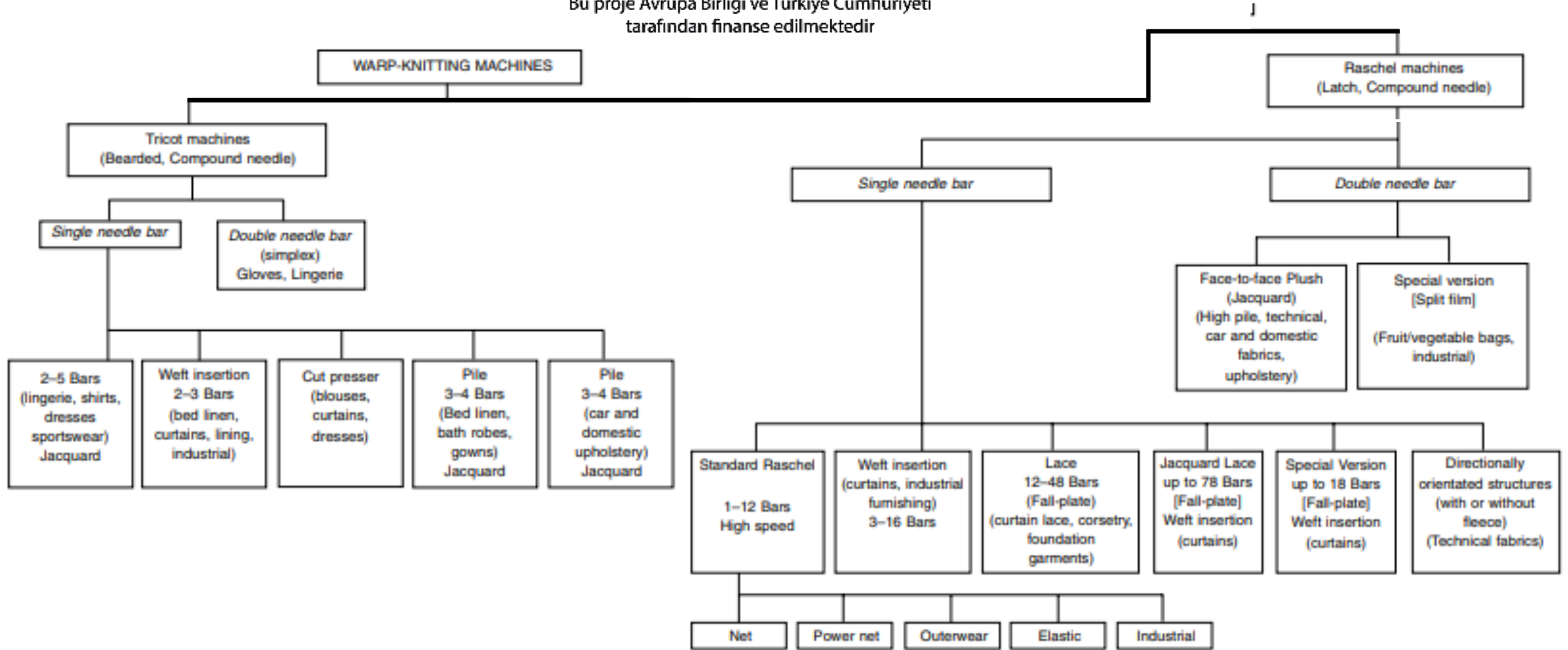

Sınıflandırma



ÖRME KUMAŞLAR

Bu proje Avrupa Birliği ve Türkiye Cumhuriyeti tarafından finanse edilmektedir

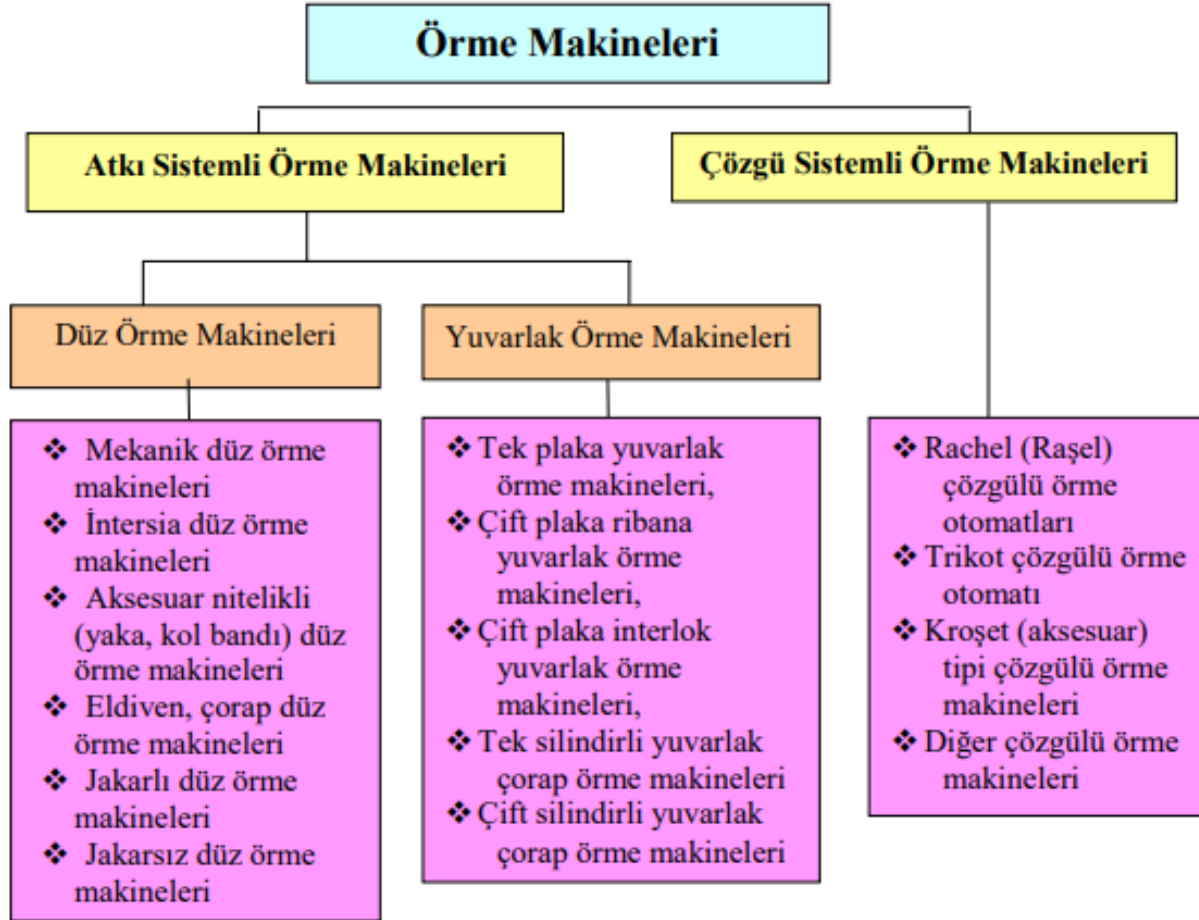

Sınıflandırma



ÖRME KUMAŞLAR

Bu proje Avrupa Birliği ve Türkiye Cumhuriyeti tarafından finanse edilmektedir

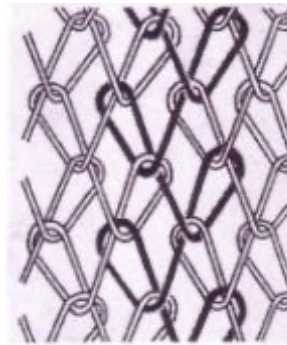
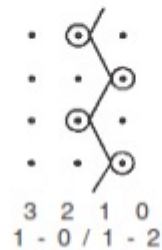
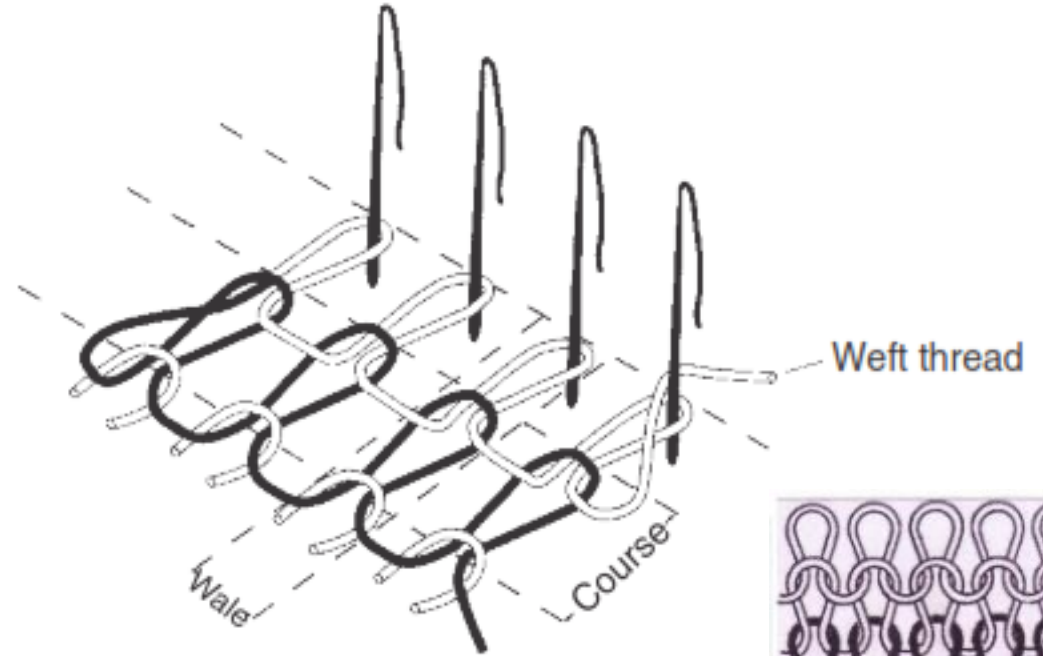
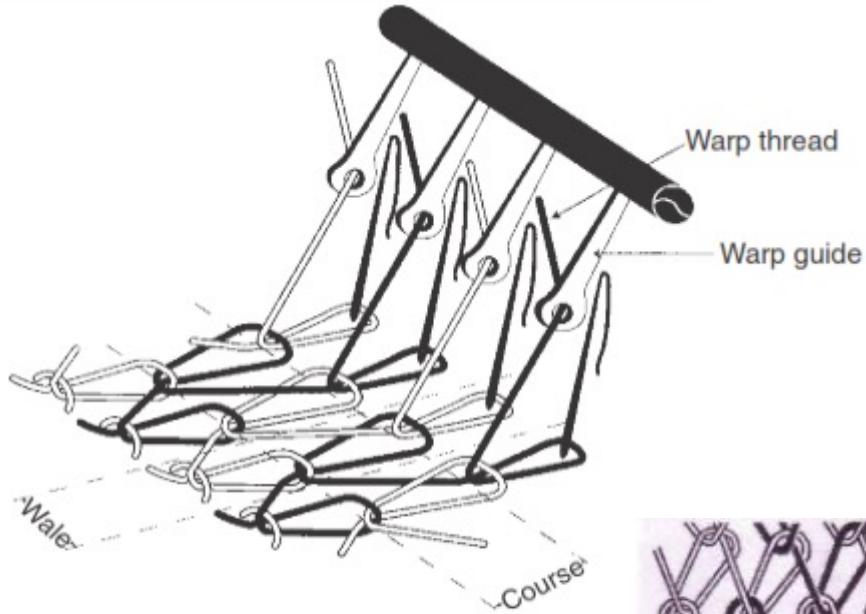

Çözümlü örme yüzey

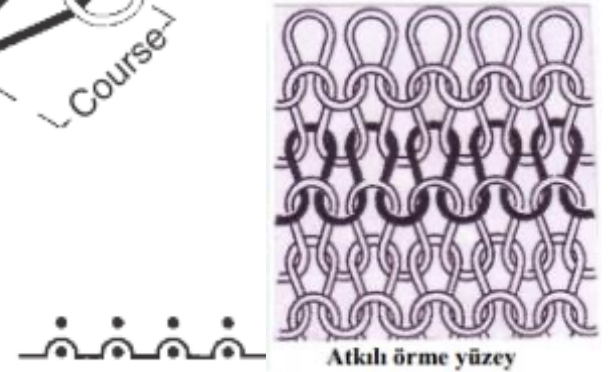

Atkılı örme yüzey



İğne Tipleri



ÖRME KUMAŞLAR

Bu proje Avrupa Birliği ve Türkiye Cumhuriyeti tarafından finanse edilmektedir

Esnek uçlu iğne

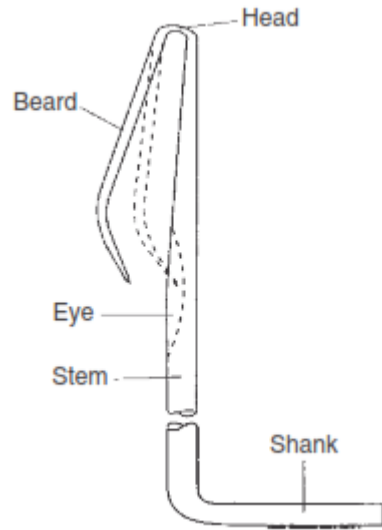

Dilli iğne

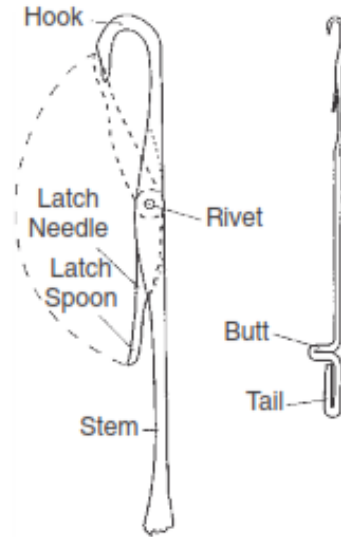

Sinek iğne

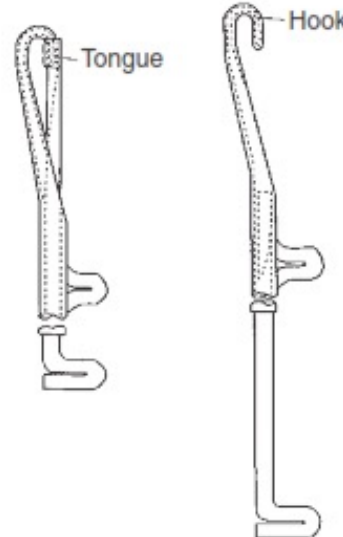

Sürgülü iğne (Kokett)

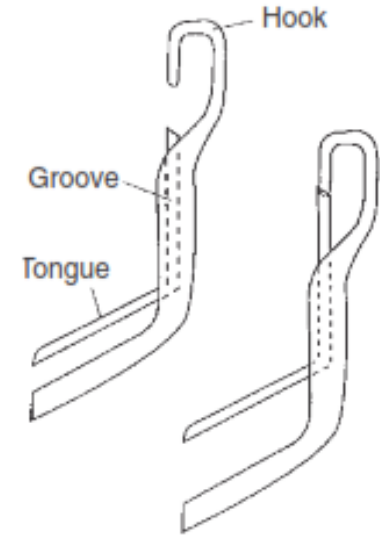

Atkılı Örme Mandallı İğne



Bu proje Avrupa Birliği ve Türkiye Cumhuriyeti tarafından finanse edilmektedir

ÖRME MAKİNESİ

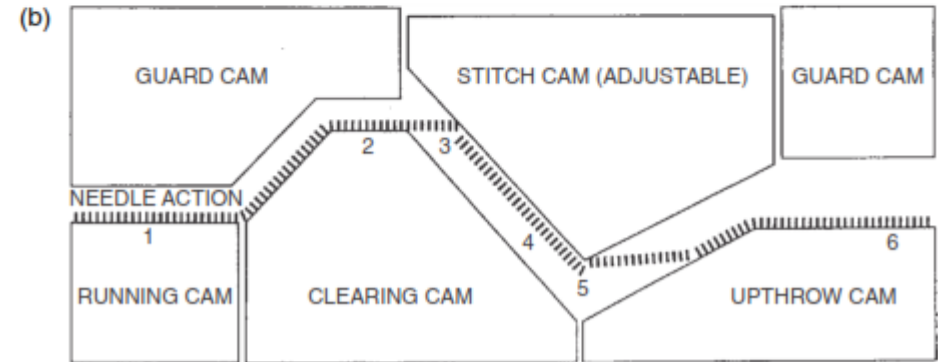
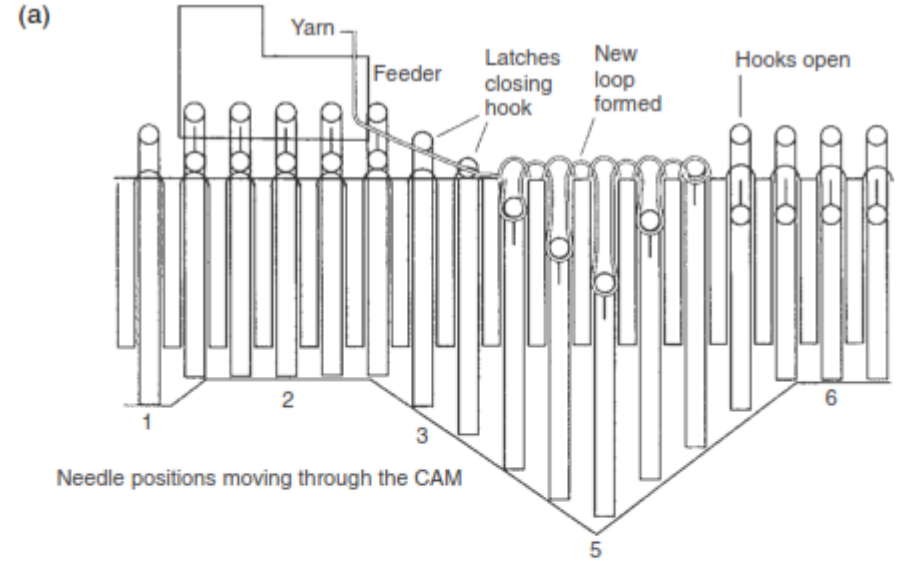
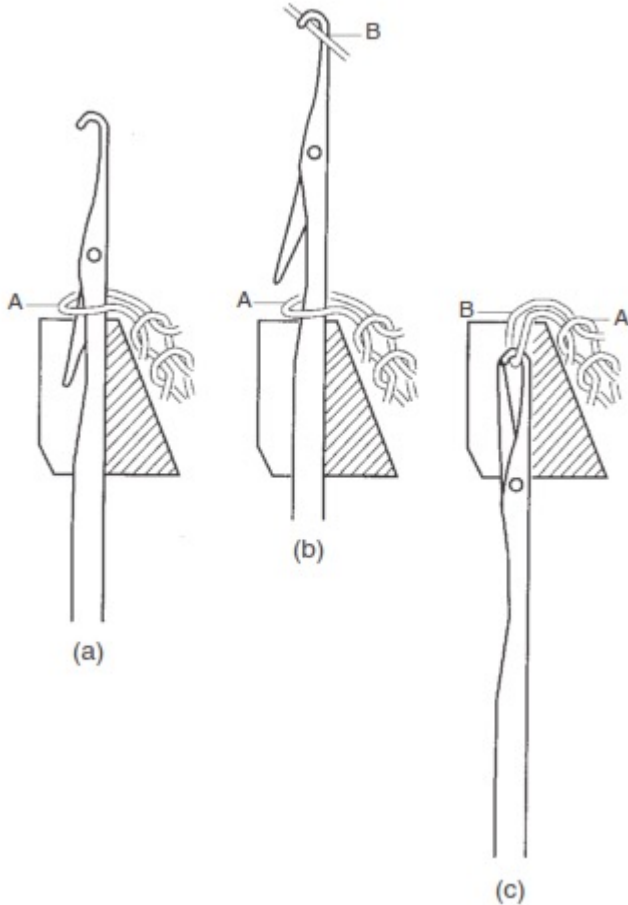

Atkılı Örme Örgü Yapıları



ÖRME MAKİNESİ

Bu proje Avrupa Birliği ve Türkiye Cumhuriyeti tarafından finanse edilmektedir

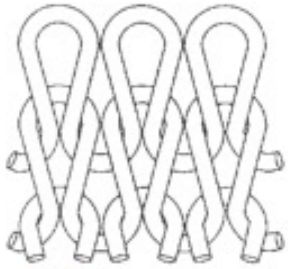

Plain single-jersey A
Technical Face

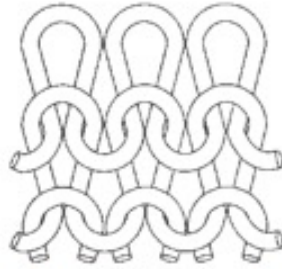

Plain single-jersey B
Technical Back

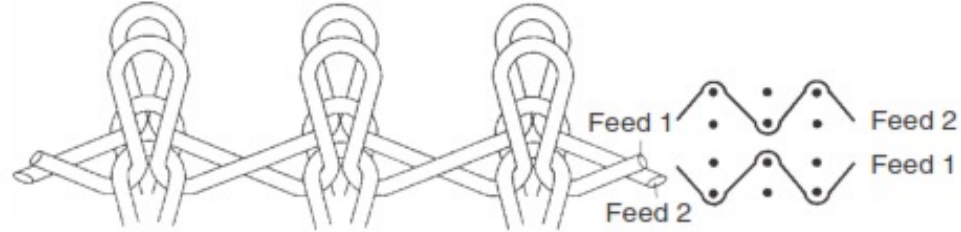

Interlock E

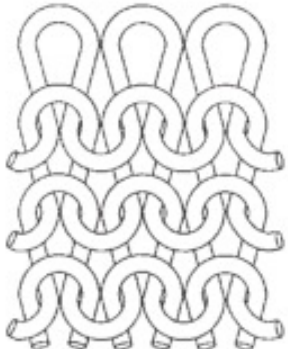

1x1 Rib C



1x1 Purl D



Feed 2

Feed 1

Feed 2

Feed 1

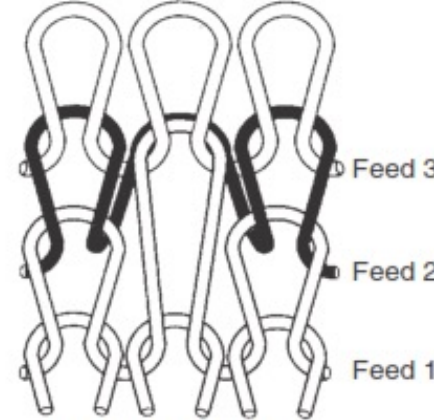

Single Tuck Stitch F

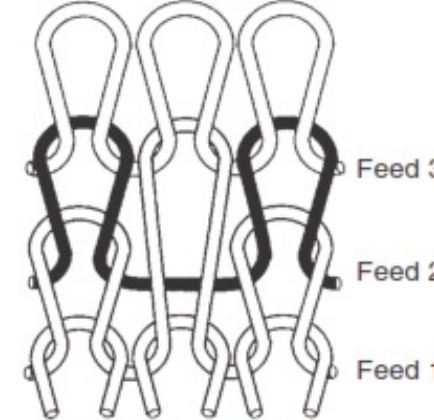

Single Tuck Stitch G



Çözümlü Örme



ÖRME MAKİNESİ

Bu proje Avrupa Birliği ve Türkiye Cumhuriyeti tarafından finanse edilmektedir

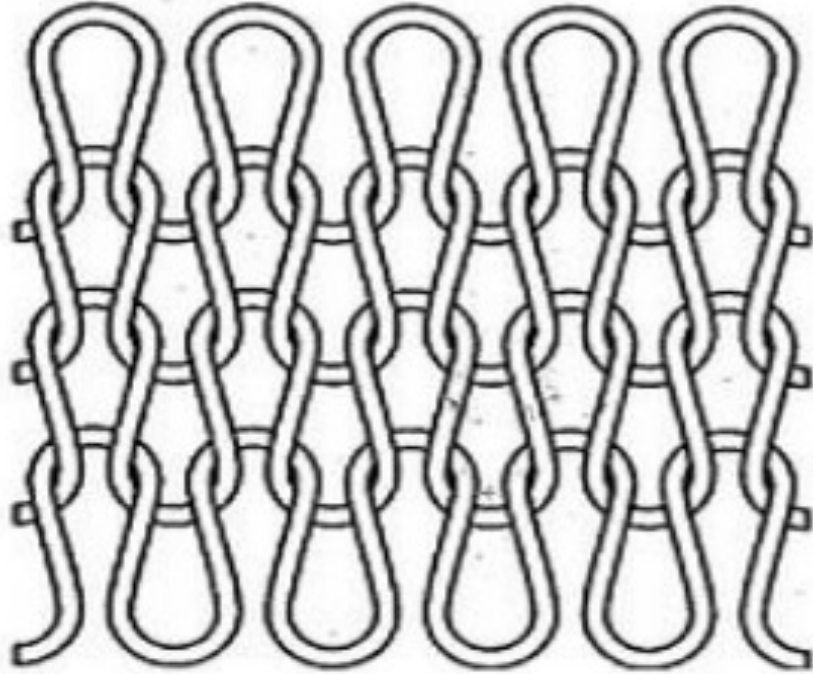

Weft Knitting

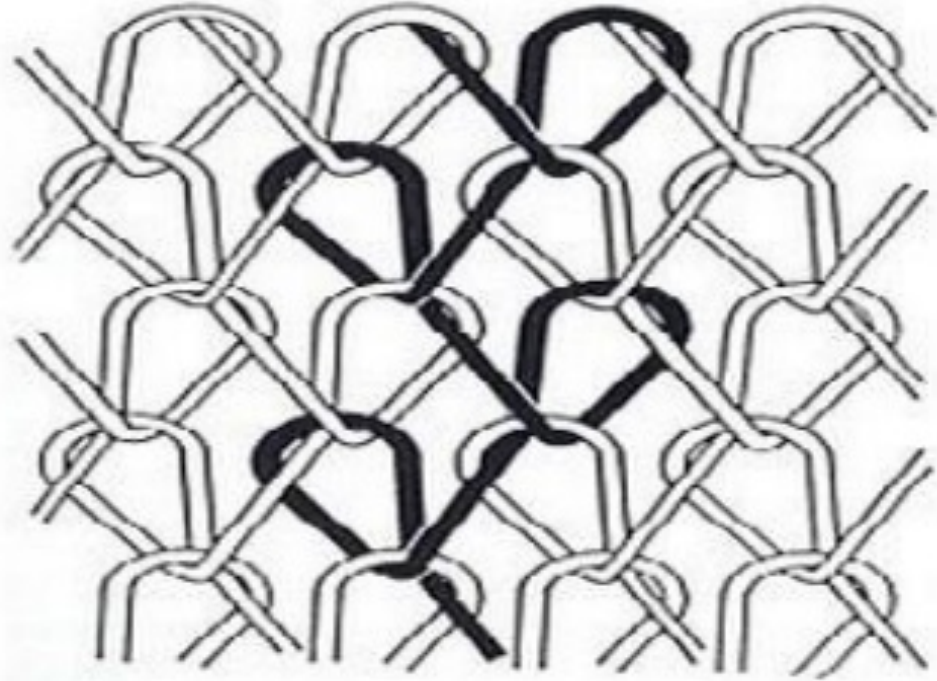

Warp Knitting



Çözgülu Örme İlmek Oluşumu



Bu proje Avrupa Birliđi ve Türkiye Cumhuriyeti tarafından finanse edilmektedir

ÖRME MAKİNESİ

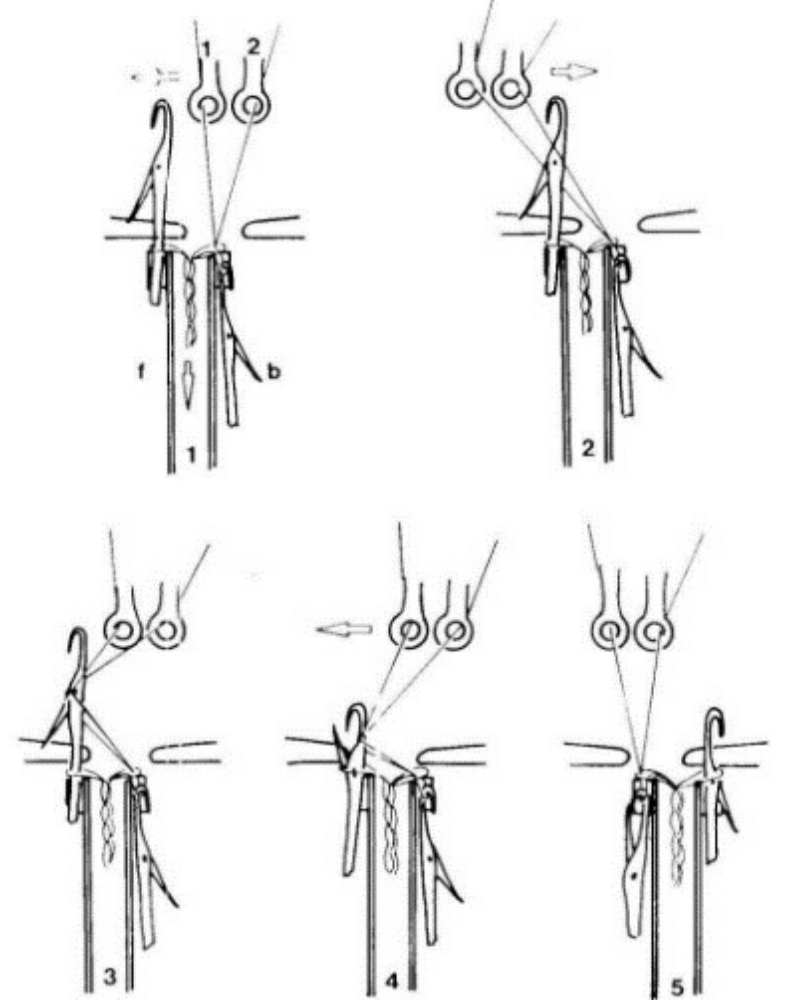
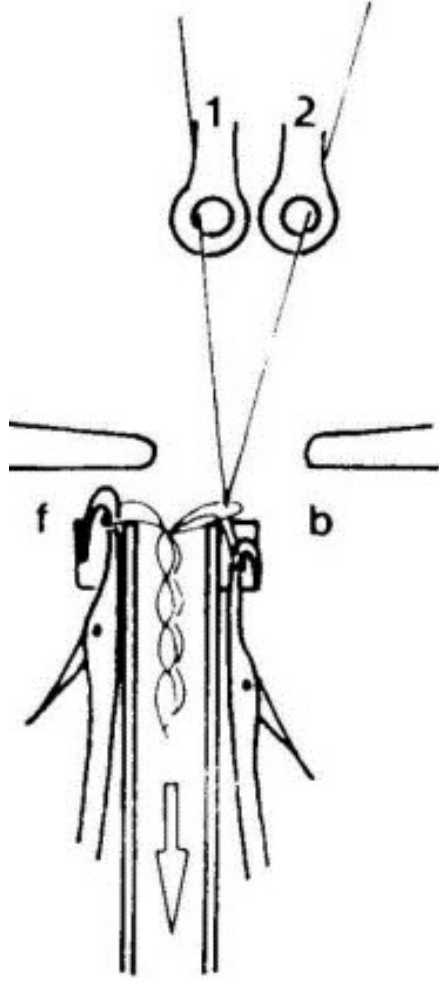

Çözgüdü Örme

1 x 1



Bu proje Avrupa Birliği ve Türkiye Cumhuriyeti tarafından finanse edilmektedir

ÖRME MAKİNESİ

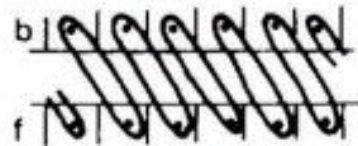
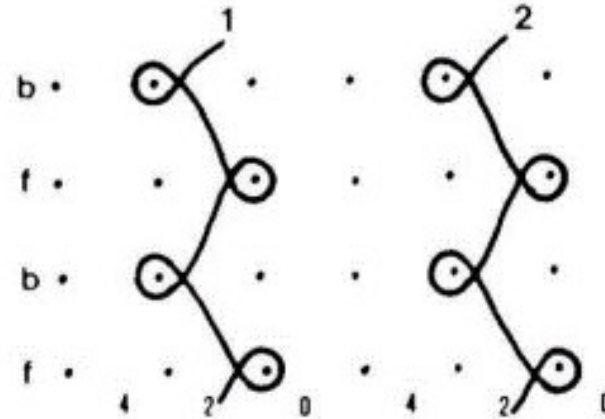

Çözgümlü Örme İki yüzlü kumaş oluşumu



Bu proje Avrupa Birliği ve Türkiye Cumhuriyeti tarafından finanse edilmektedir

ÖRME MAKİNESİ

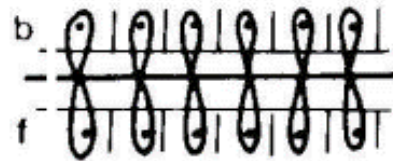
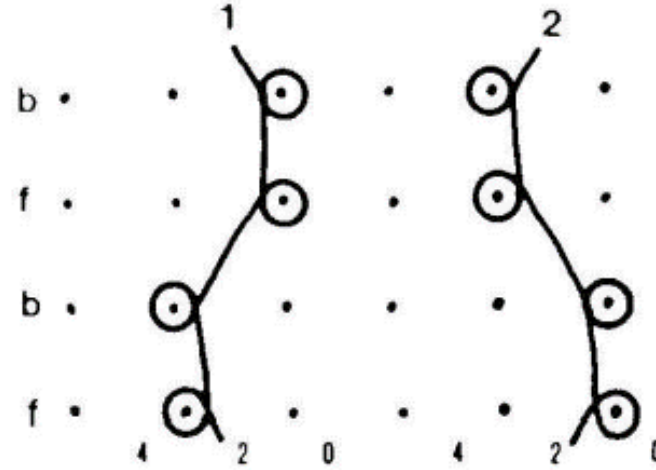
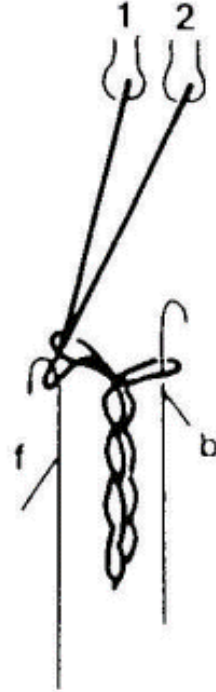

Çözgülü Örme

İki kumaş oluşumu



Bu proje Avrupa Birliği ve Türkiye Cumhuriyeti tarafından finanse edilmektedir

ÖRME MAKİNESİ

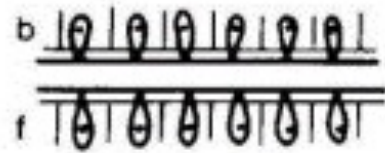
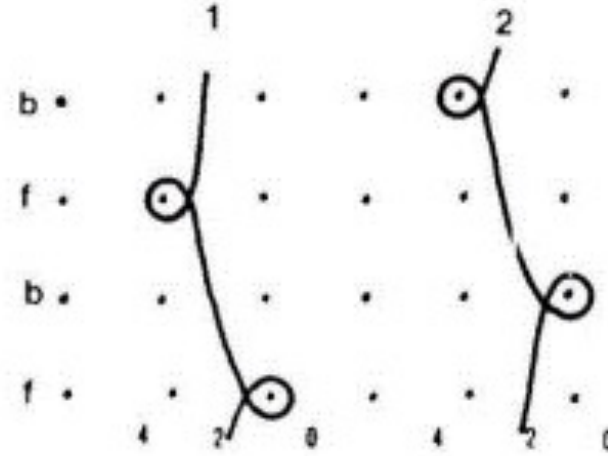

Çözgülü Örme

Birbirine kilitli iki kumaş oluşumu



Bu proje Avrupa Birliği ve Türkiye Cumhuriyeti tarafından finanse edilmektedir

ÖRME MAKİNESİ

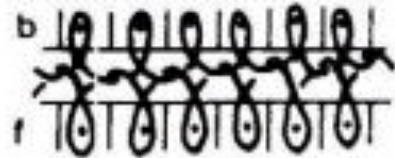
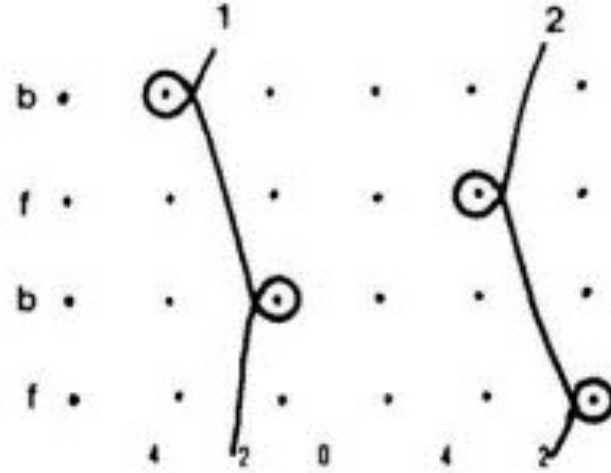

Çözgülü Örme

Tüp kumaş oluşumu



Bu proje Avrupa Birliği ve Türkiye Cumhuriyeti tarafından finanse edilmektedir

ÖRME MAKİNESİ

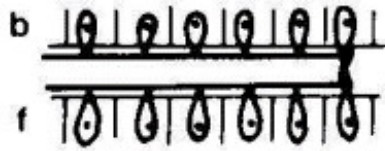
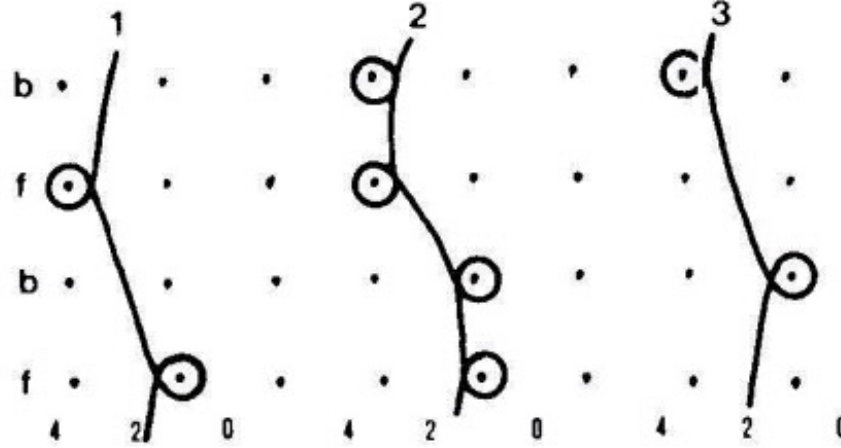
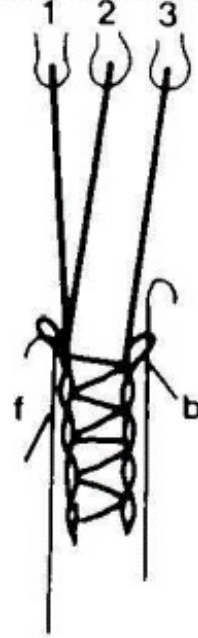

a

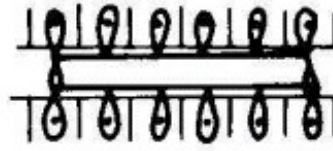

b

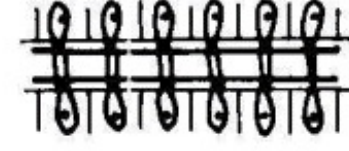

c

Çözgülü Örme Sandviç kumaş oluşumu



Bu proje Avrupa Birliği ve Türkiye Cumhuriyeti tarafından finanse edilmektedir

ÖRME MAKİNESİ

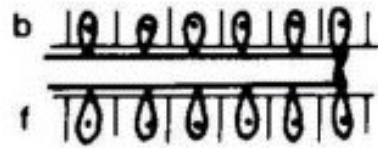
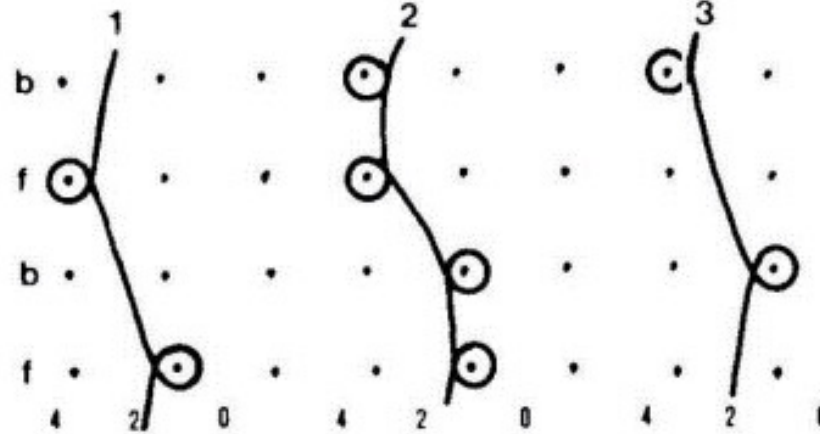

a

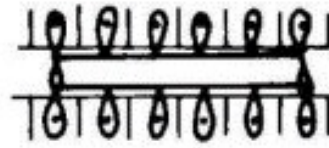

b

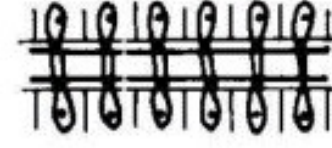

c

Çok Eksenli Örme



ÖRME MAKİNESİ

Bu proje Avrupa Birliği ve Türkiye Cumhuriyeti tarafından finanse edilmektedir

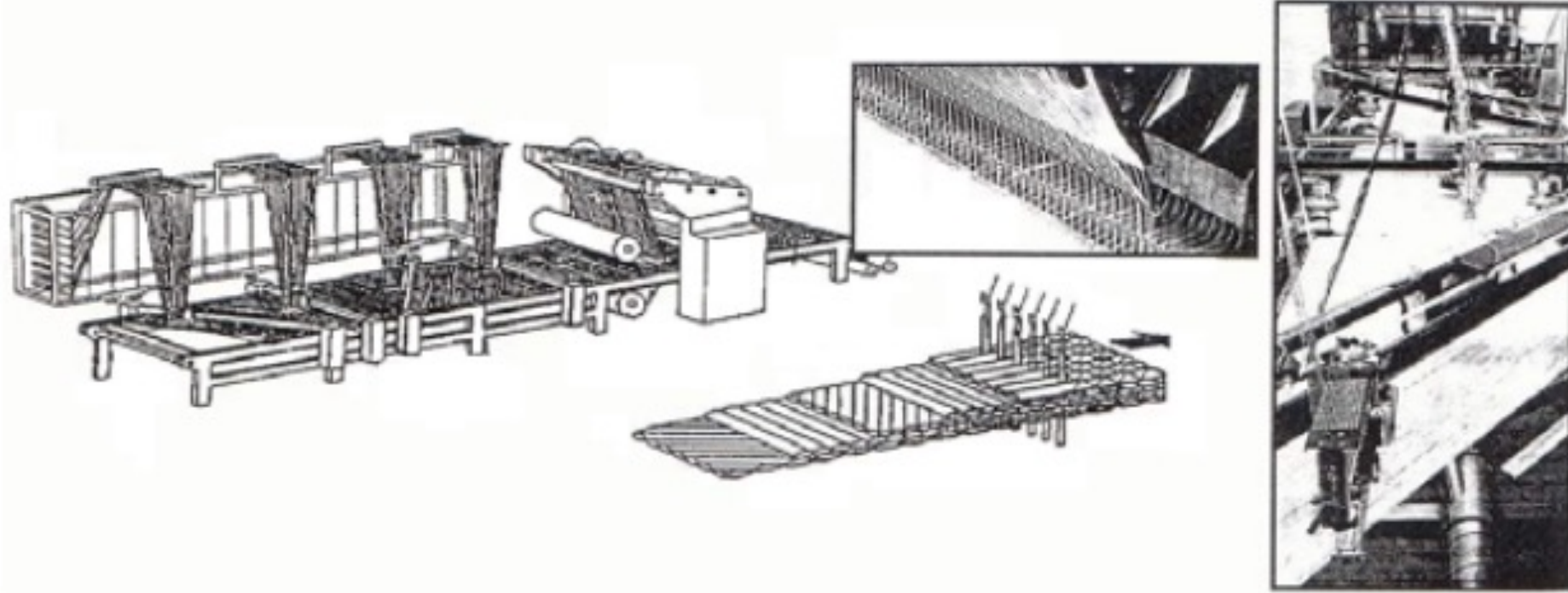

Çok Eksenli Örme



ÖRME MAKİNESİ

Bu proje Avrupa Birliği ve Türkiye Cumhuriyeti tarafından finanse edilmektedir

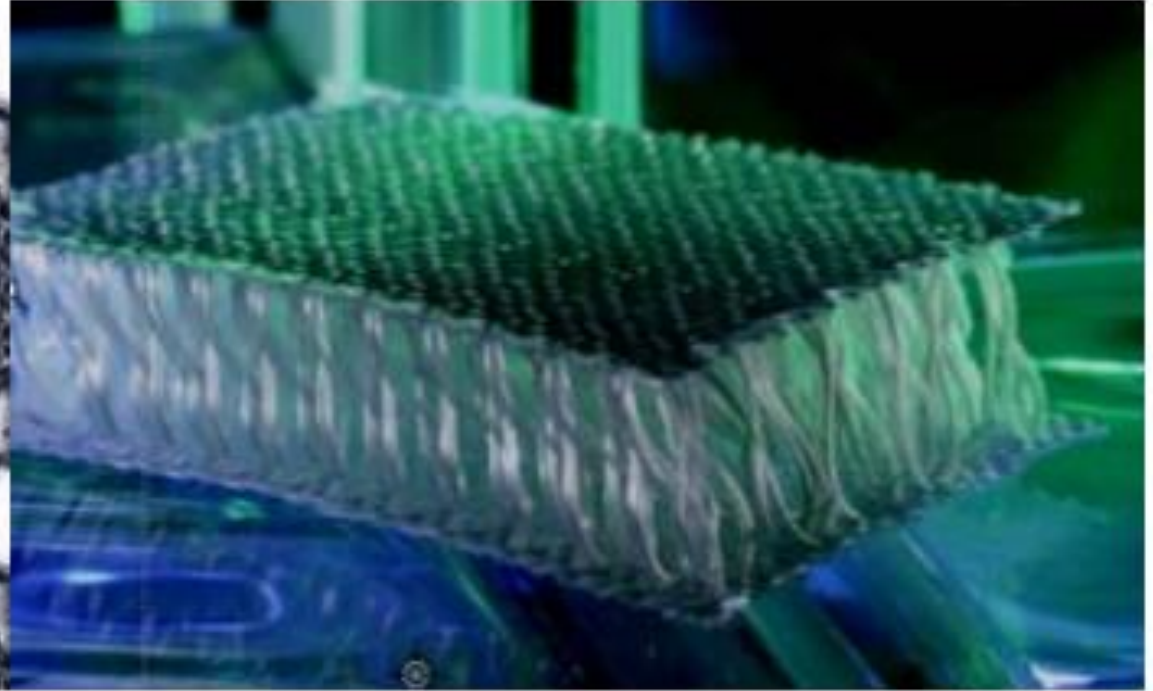

Çok Eksenli Örme



Bu proje Avrupa Birliği ve Türkiye Cumhuriyeti tarafından finanse edilmektedir

ÖRME MAKİNESİ

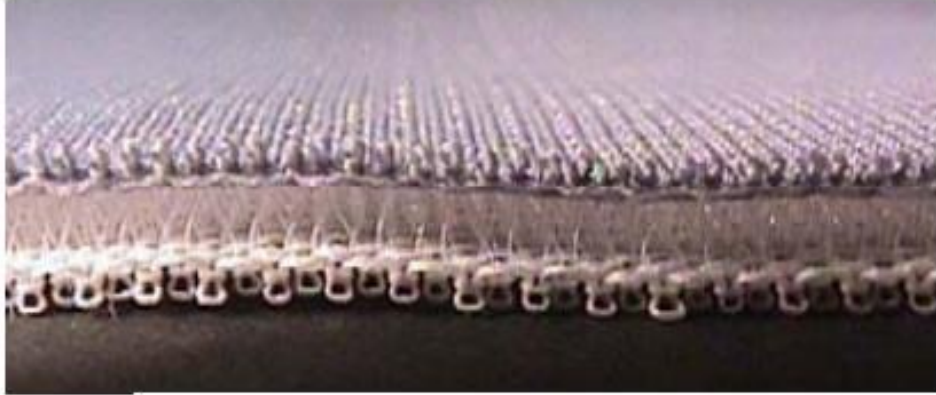

Çok Eksenli Örme



ÖRME MAKİNESİ

Bu proje Avrupa Birliği ve Türkiye Cumhuriyeti tarafından finanse edilmektedir

Kapalı uygulama

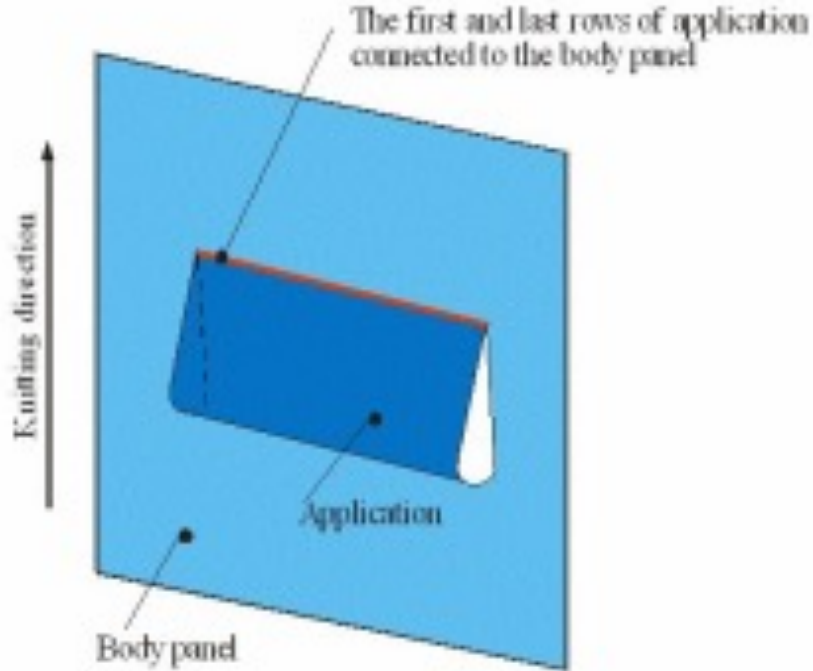

Açık uygulama

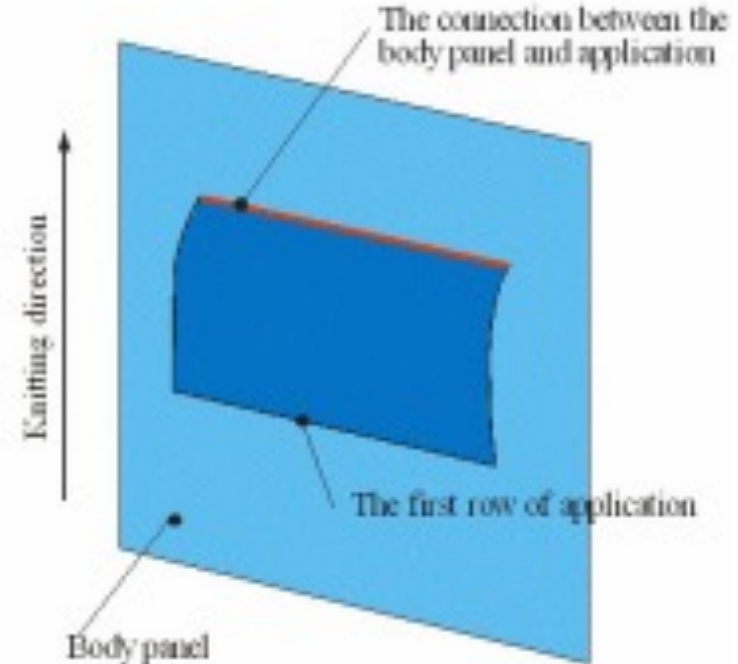

Çok Eksenli Örme

Cep oluşumu



ÖRME MAKİNESİ

Bu proje Avrupa Birliği ve Türkiye Cumhuriyeti tarafından finanse edilmektedir

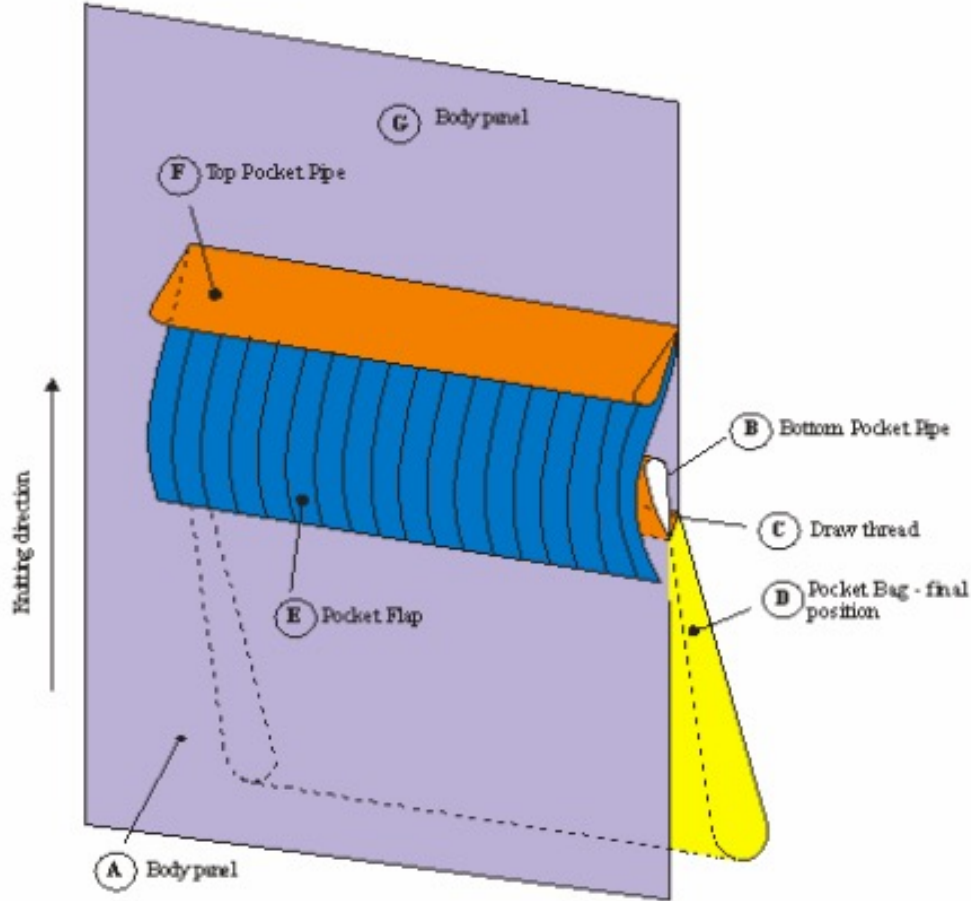

Çok Eksenli Örme 3D Desenler



ÖRME MAKİNESİ

Bu proje Avrupa Birliği ve Türkiye Cumhuriyeti tarafından finanse edilmektedir

Raf hareketi ile 3D desen



İntersia deseni ile 3D tasarım



Çok Eksenli Örme Esnek dikiş tekniği



ÖRME MAKİNESİ

Bu proje Avrupa Birliği ve Türkiye Cumhuriyeti tarafından finanse edilmektedir



Single jersey



Rib 5:5



Single jersey and rib



Tubular



Çok Eksenli Örme Örme ve Giydirme teknîği



ÖRME MAKİNESİ

Bu proje Avrupa Birliği ve Türkiye Cumhuriyeti tarafından finanse edilmektedir

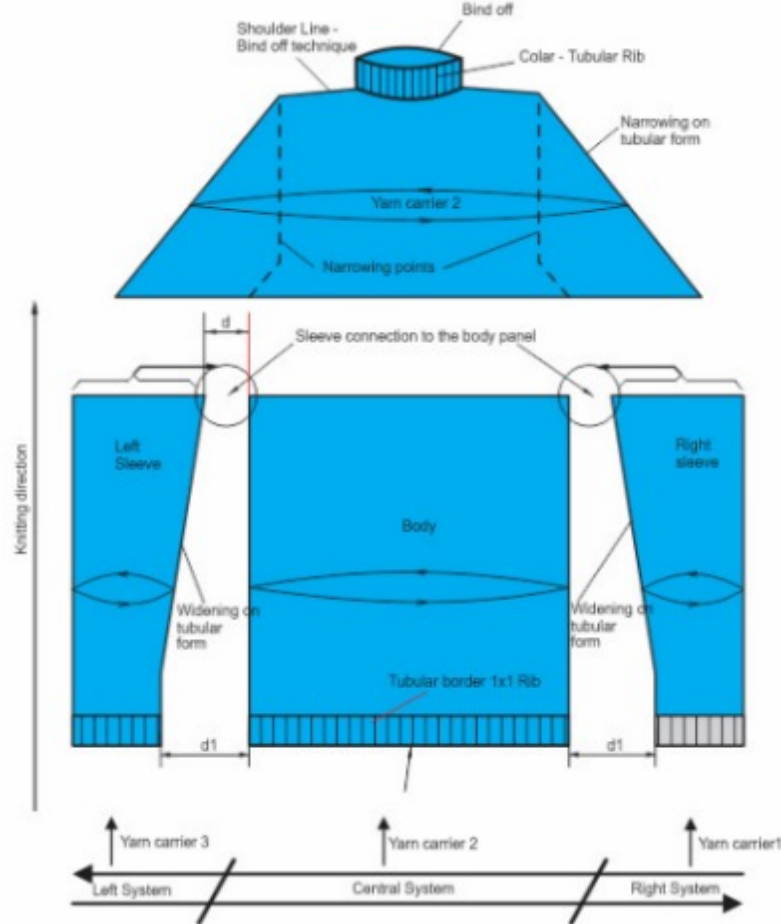

Çok Katmanlı Kumaşlar



ÖRME MAKİNESİ

Bu proje Avrupa Birliği ve Türkiye Cumhuriyeti tarafından finanse edilmektedir



Çok Katmanlı Kumaşlar

Çalışma Prensipleri



Bu proje Avrupa Birliği ve Türkiye Cumhuriyeti tarafından finanse edilmektedir

ÖRME MAKİNESİ

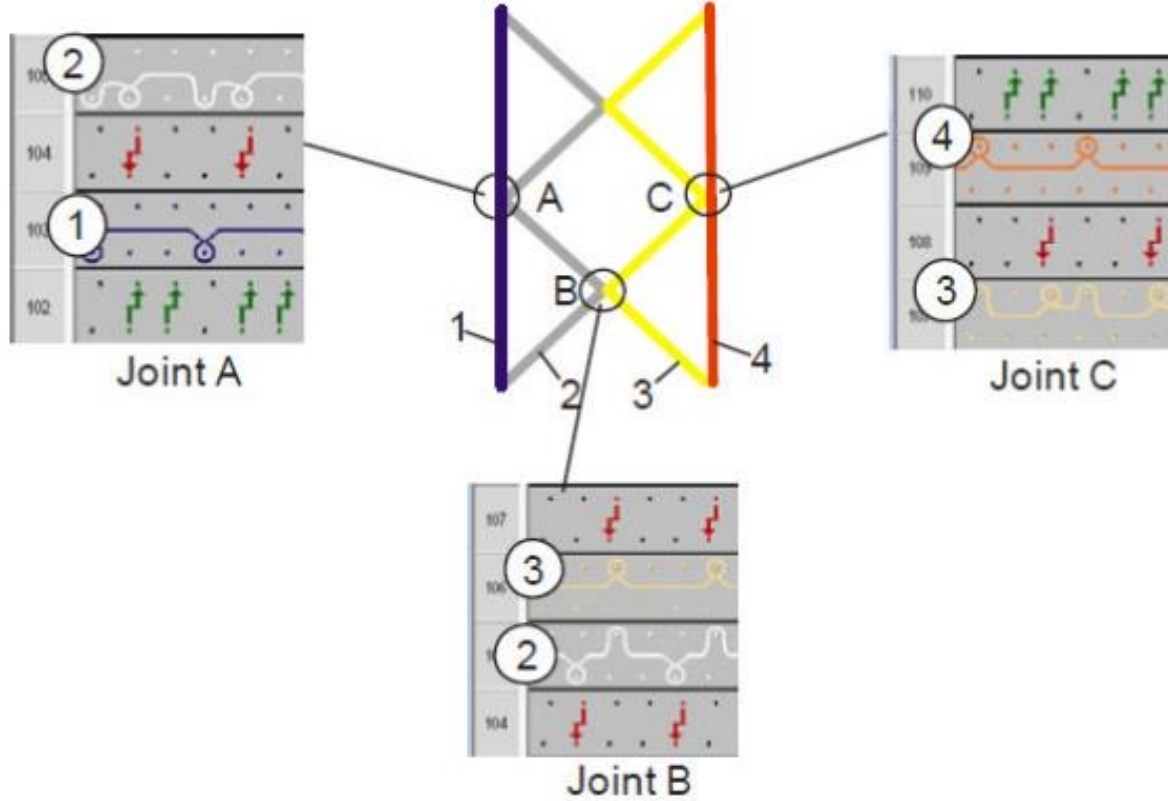

Çok Katmanlı Kumaşlar Kama Tekniği



Bu proje Avrupa Birliği ve Türkiye Cumhuriyeti tarafından finanse edilmektedir

ÖRME MAKİNESİ

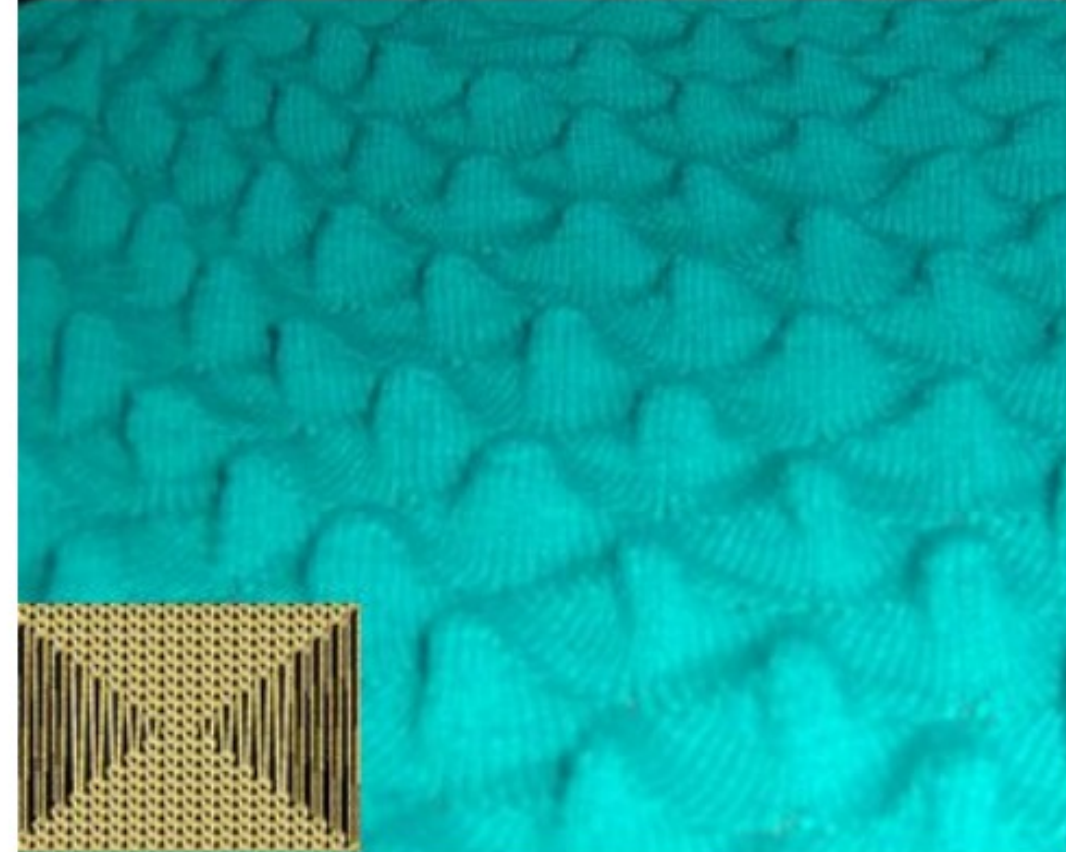
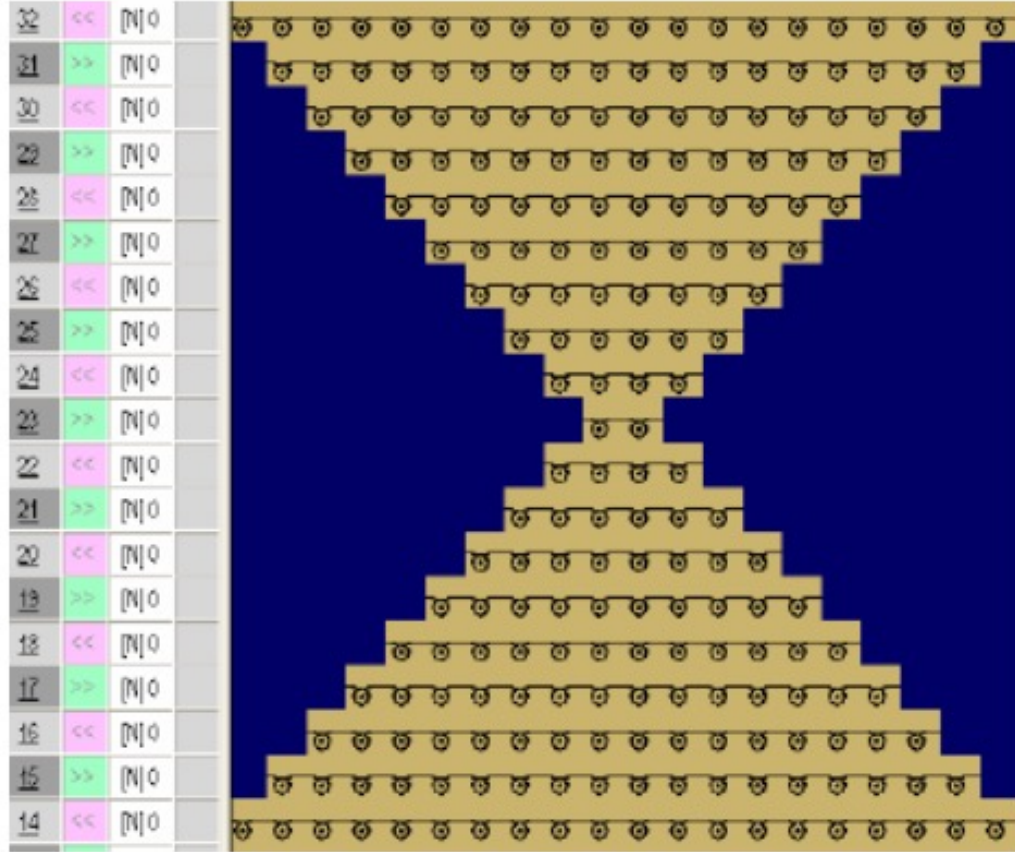

Çok Katmanlı Kumaşlar Birbirine bağlama teknikği



Bu proje Avrupa Birliği ve Türkiye Cumhuriyeti tarafından finanse edilmektedir

ÖRME MAKİNESİ

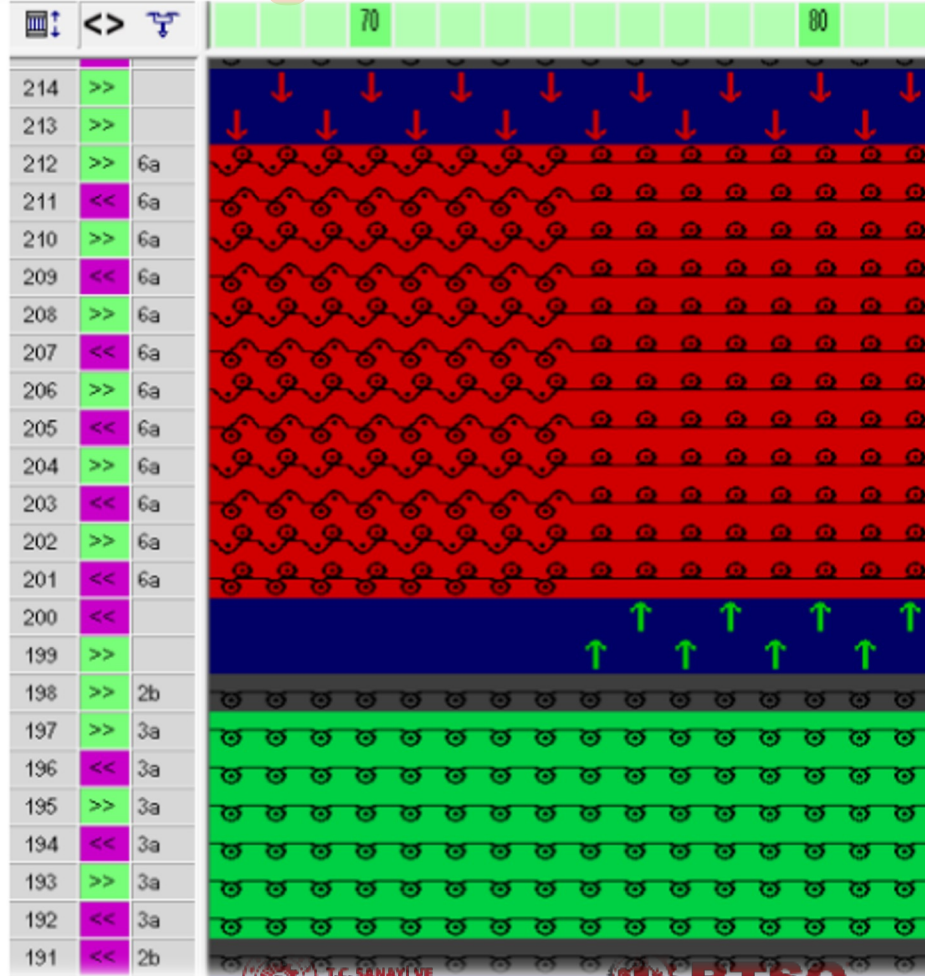

İlme Oluşumu Mandallı İğne



Bu proje Avrupa Birliği ve Türkiye Cumhuriyeti tarafından finanse edilmektedir

ÖRME MAKİNESİ

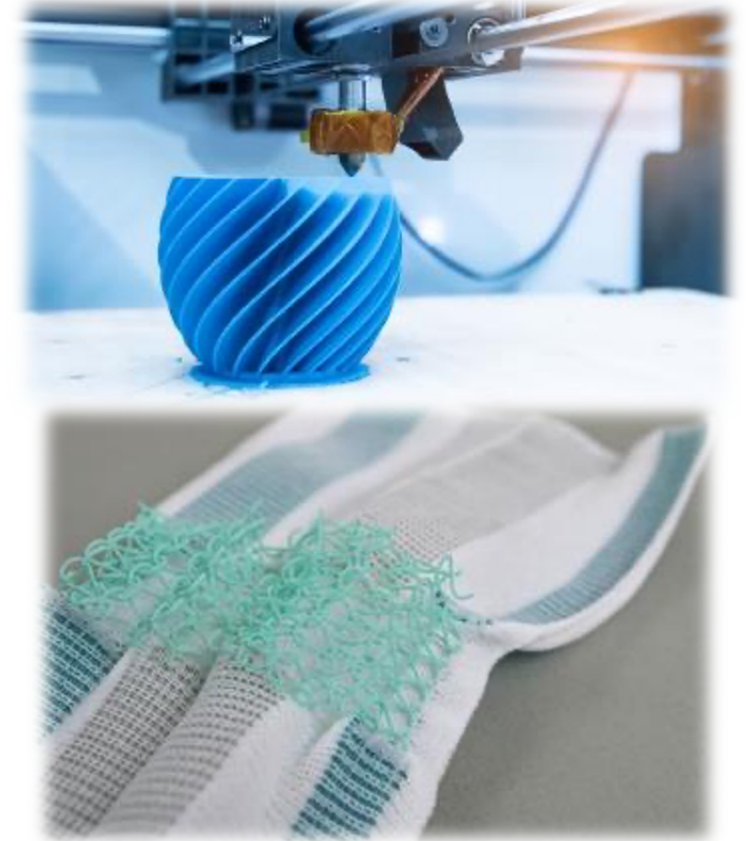
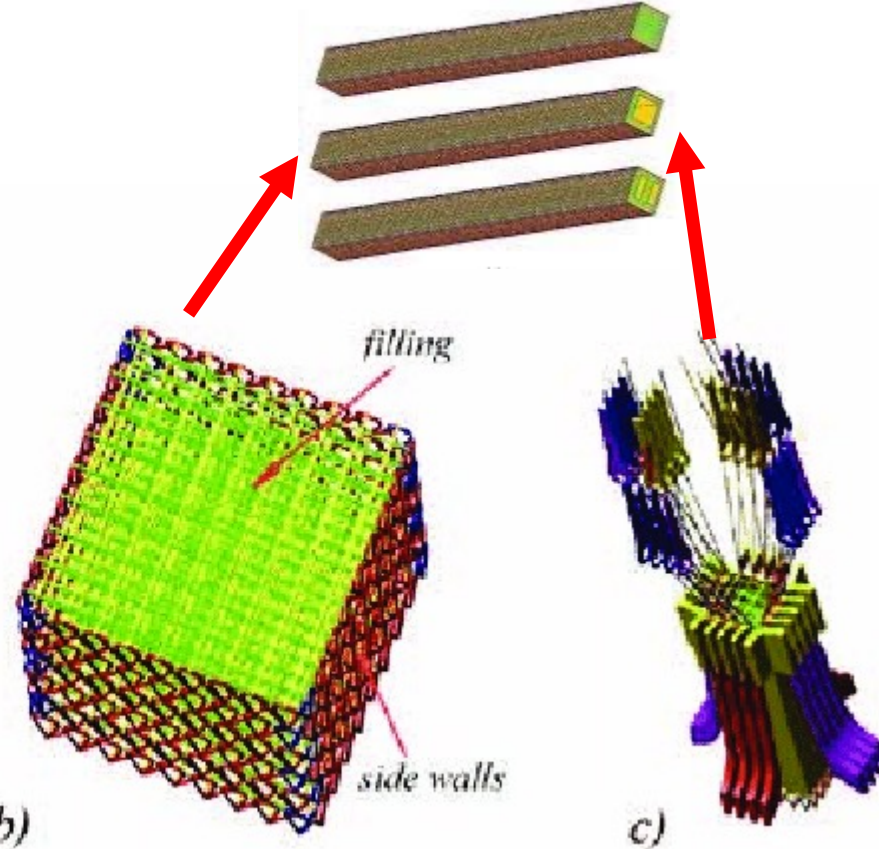

3 Boyutlu Örgü Yapıları



Bu proje Avrupa Birliği ve Türkiye Cumhuriyeti tarafından finanse edilmektedir

ÖRME KUMAŞLAR

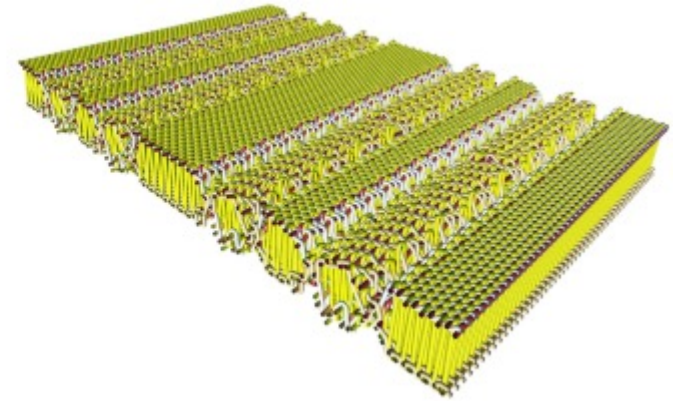
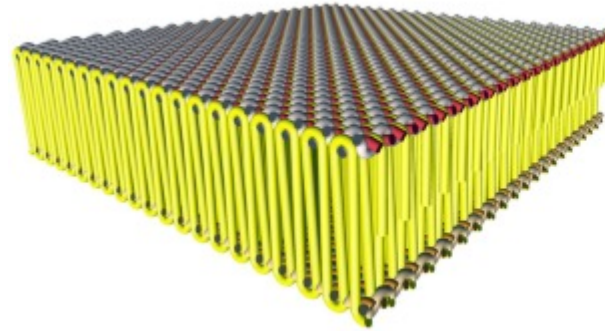
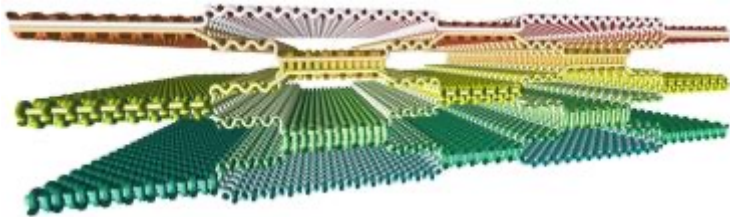
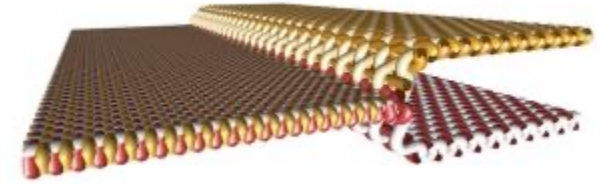
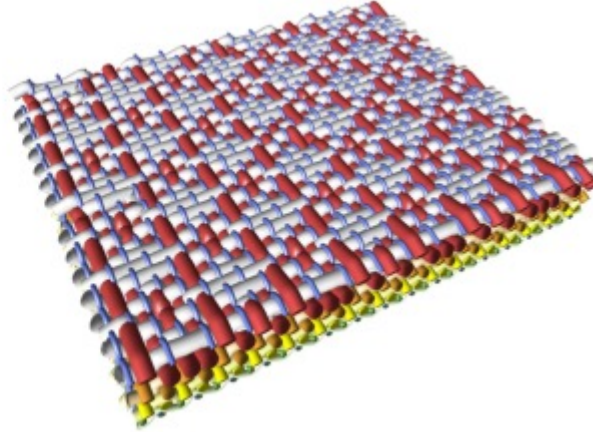
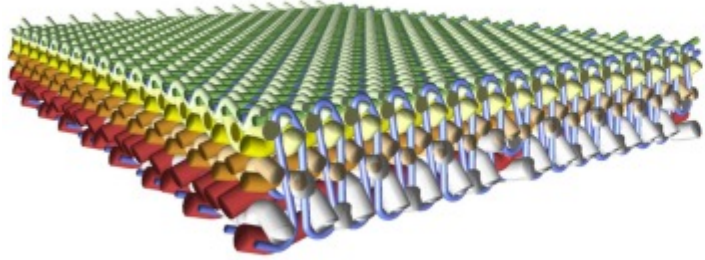

İlmeğin Oluşumu

Mandallı İğne



Bu proje Avrupa Birliği ve Türkiye Cumhuriyeti tarafından finanse edilmektedir

ÖRME MAKİNESİ

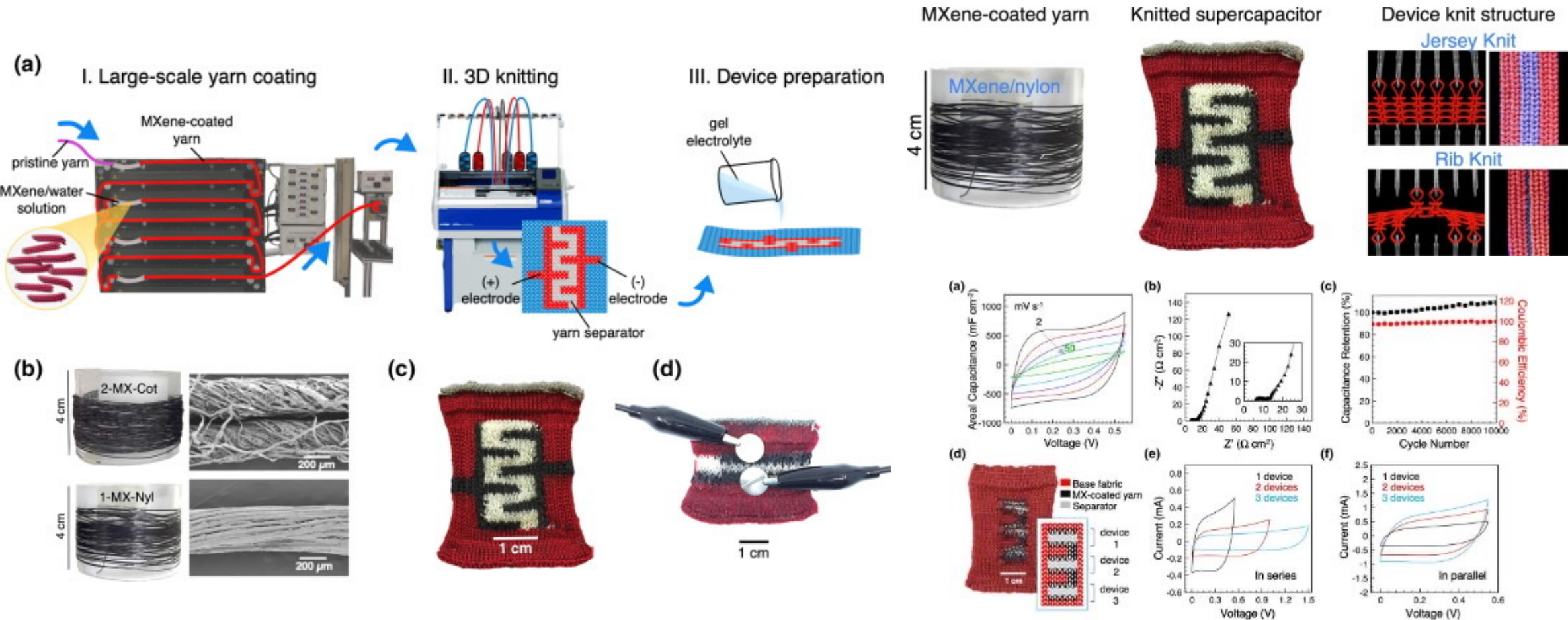



Bu proje Avrupa Birliđi ve Türkiye Cumhuriyeti tarafından finanse edilmektedir

6. Bölüm

DOKUSUZ YÜZEYLER



Sınıflandırma



DOKUSUZ YÜZEYLER

Bu proje Avrupa Birliği ve Türkiye Cumhuriyeti tarafından finanse edilmektedir

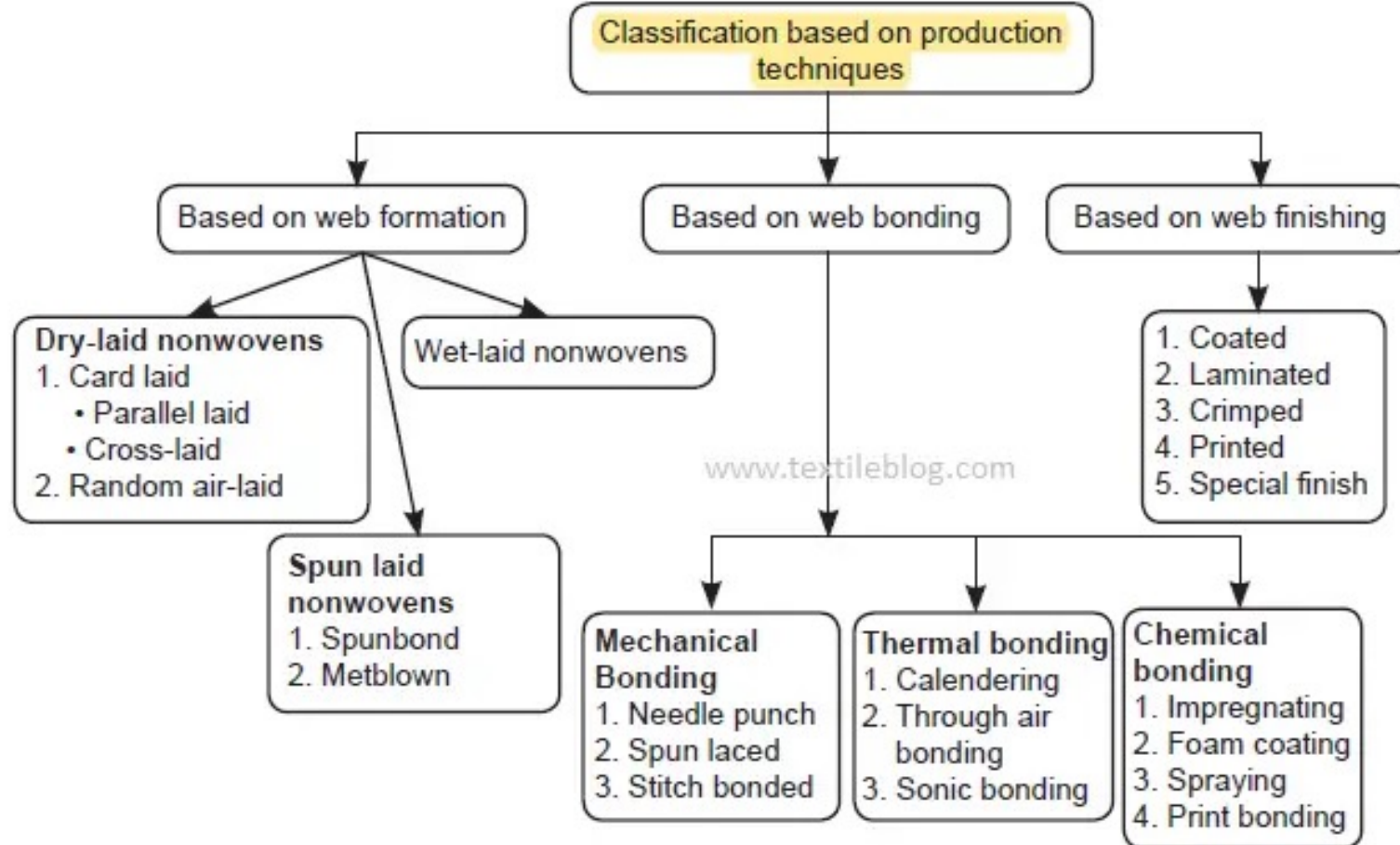

Paralel Yatırma



Bu proje Avrupa Birliği ve Türkiye Cumhuriyeti tarafından finanse edilmektedir

DOKUSUZ YÜZEYLER

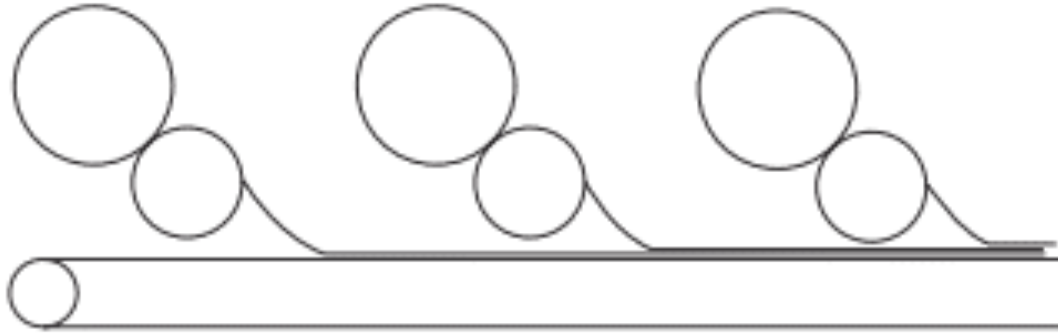

Paralel yatırma

- Kumaş eni, tarak eni ile sınırlıdır.

Alternatif paralel yatırma

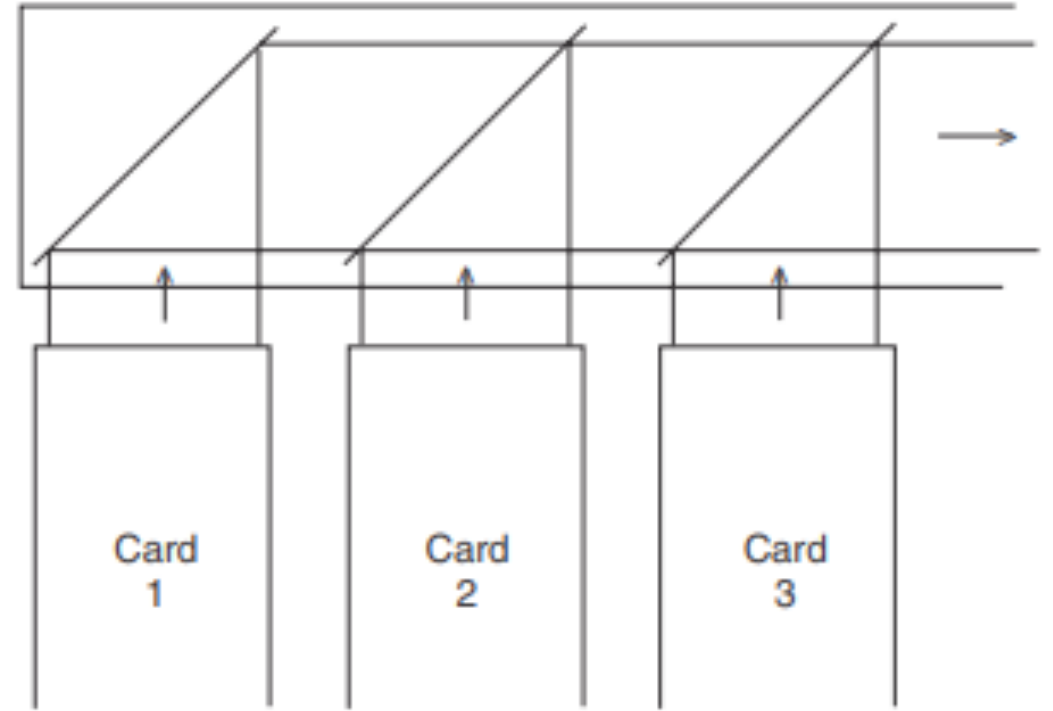

Çapraz Yatırma



Bu proje Avrupa Birliği ve Türkiye Cumhuriyeti tarafından finanse edilmektedir

DOKUSUZ YÜZEYLER

Çaprazlama tertibatı

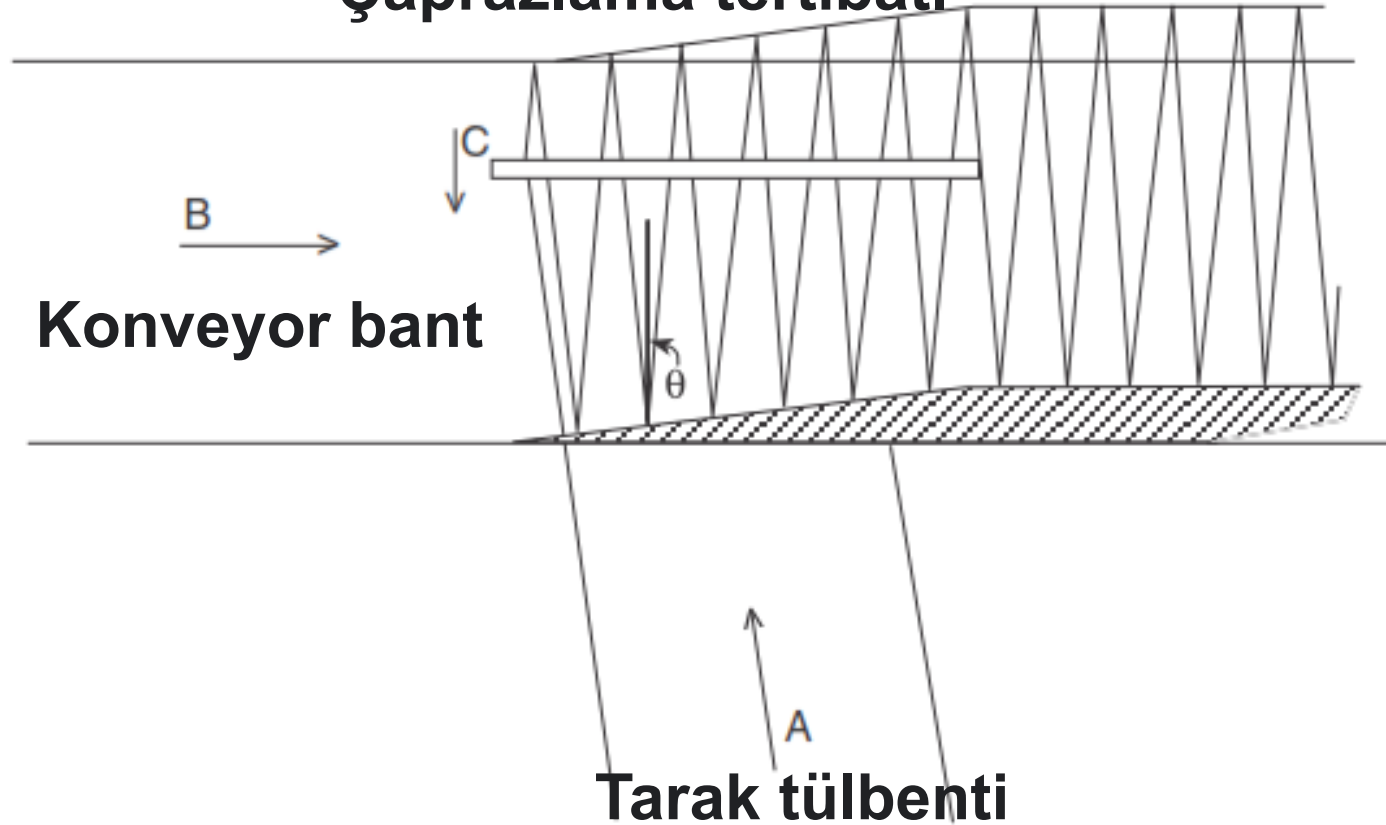

Havadan Yatırma



Bu proje Avrupa Birliği ve Türkiye Cumhuriyeti tarafından finanse edilmektedir

DOKUSUZ YÜZEYLER

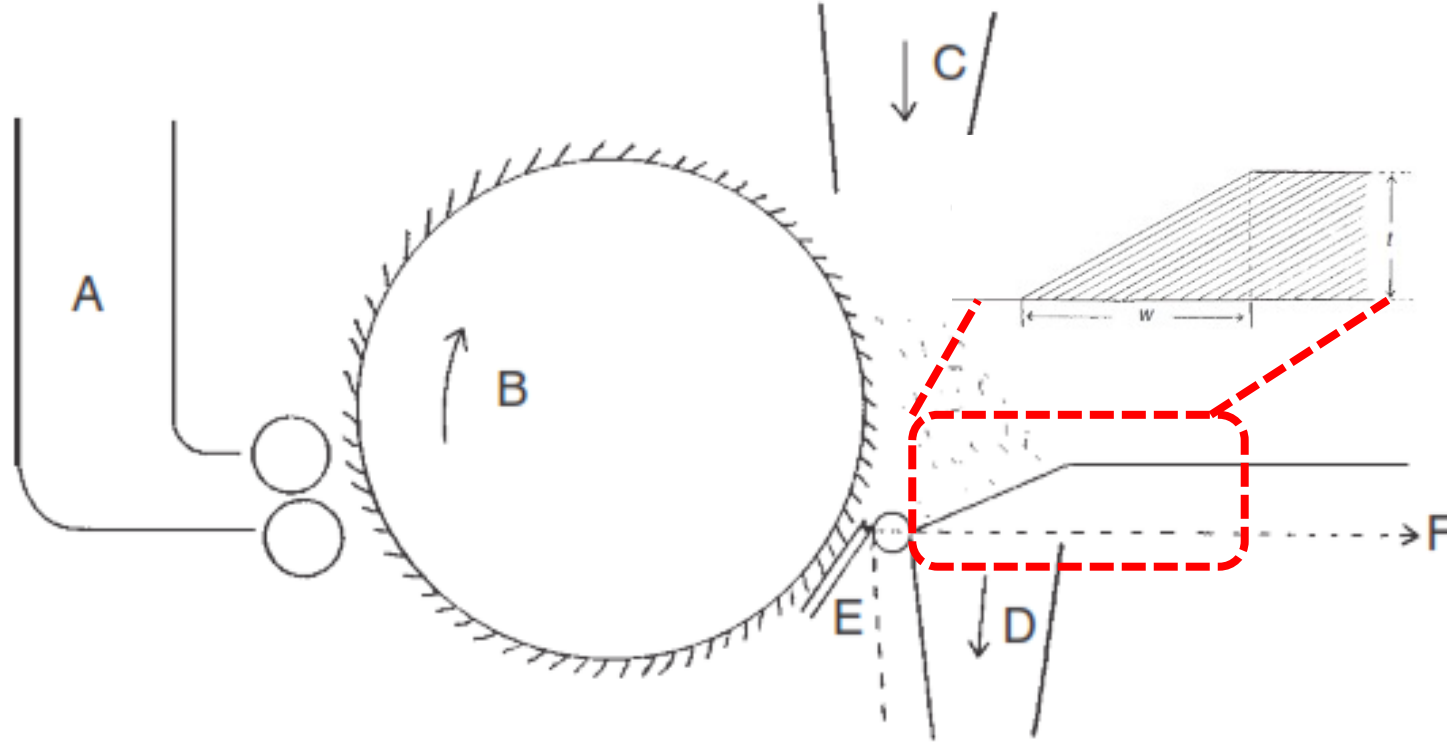

A: Hazne/oluk besleme

B: açma silindiri

C: hava akışı fan

D: fana emiş

E: sıyırma rayı

F: tampon konveyör



Islak Yatırma



DOKUSUZ YÜZEYLER

Bu proje Avrupa Birliği ve Türkiye Cumhuriyeti tarafından finanse edilmektedir

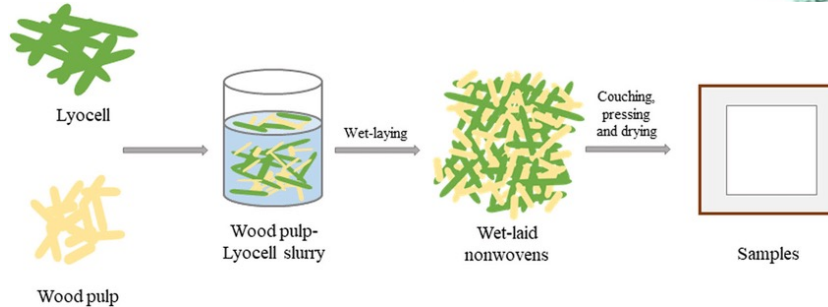
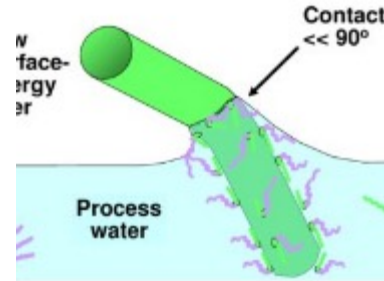
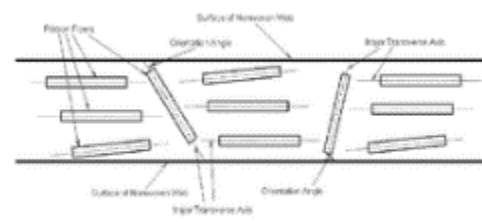
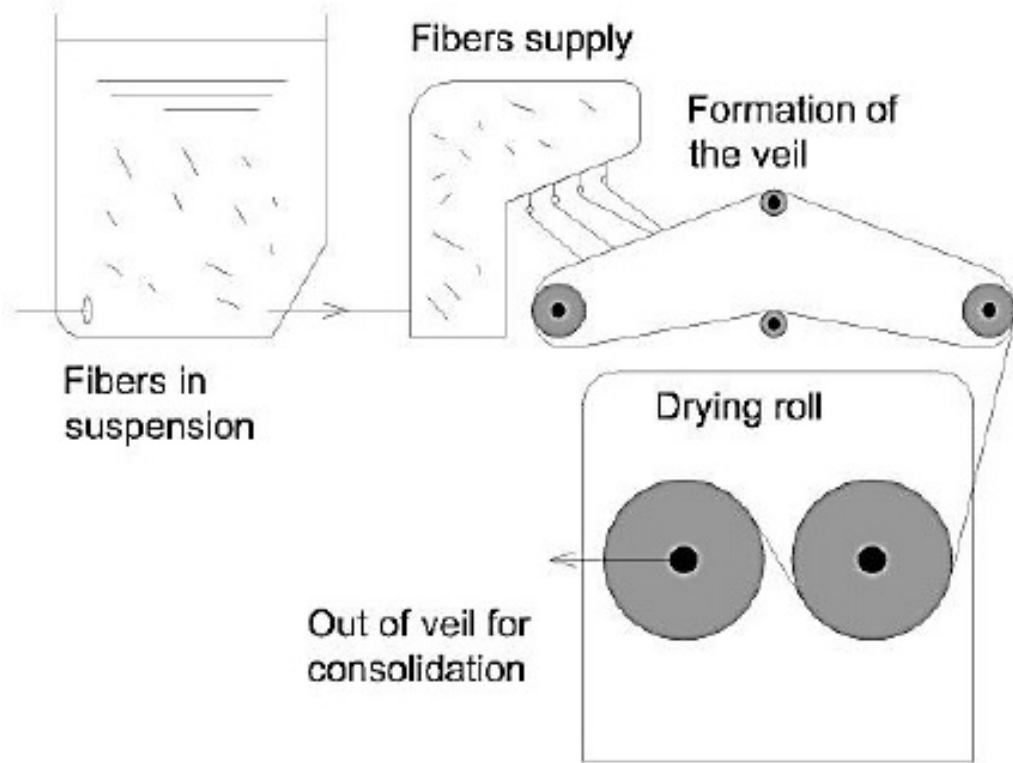

Kuru Serilmiş Odun Hamuru



DOKUSUZ YÜZEYLER

Bu proje Avrupa Birliği ve Türkiye Cumhuriyeti tarafından finanse edilmektedir

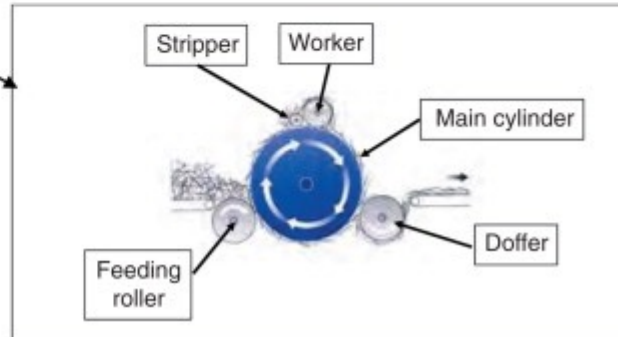
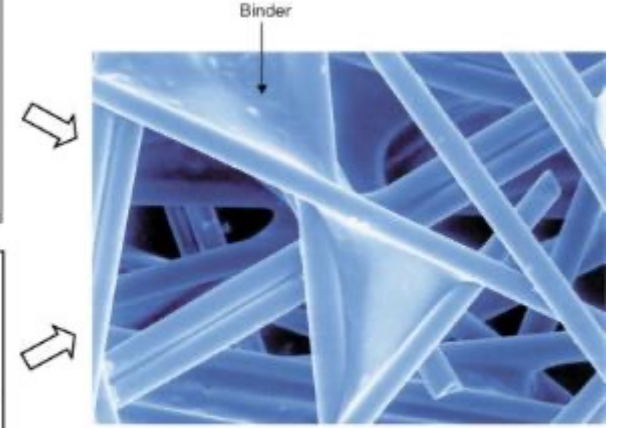
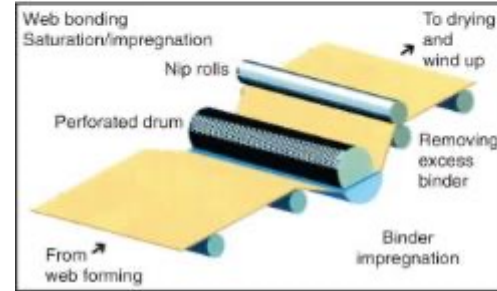
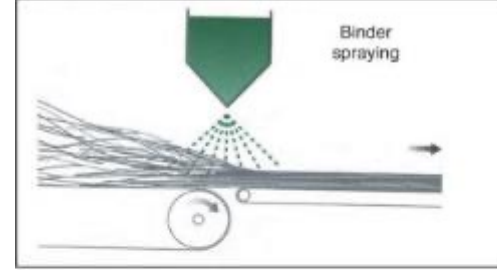
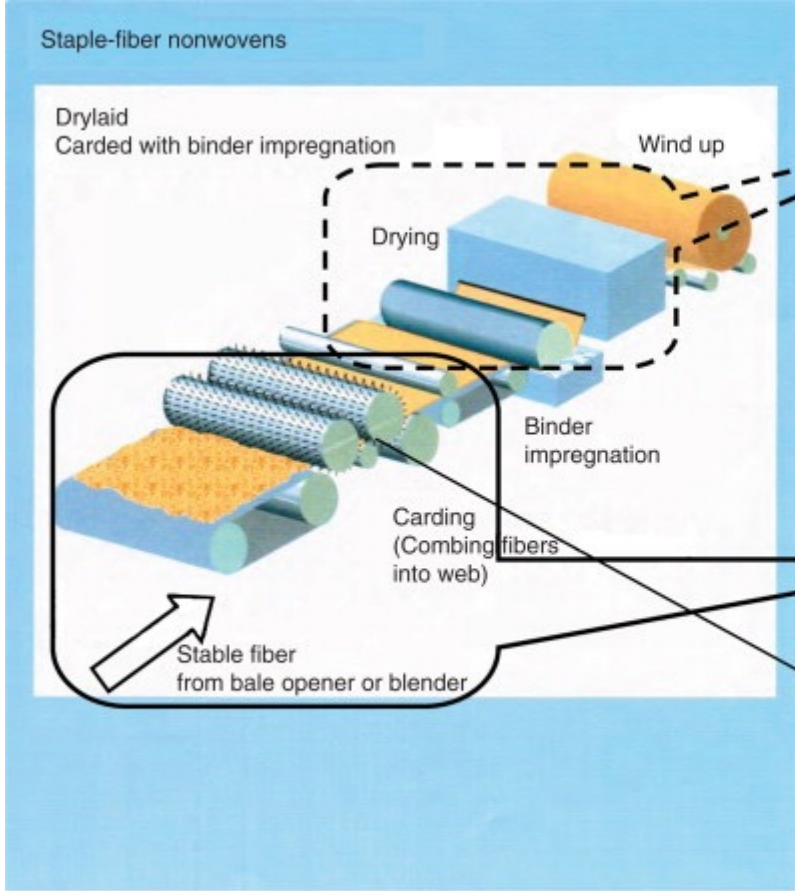

Eğirip Yatırma (Spun-laid)



Bu proje Avrupa Birliği ve Türkiye Cumhuriyeti tarafından finanse edilmektedir

DOKUSUZ YÜZEYLER

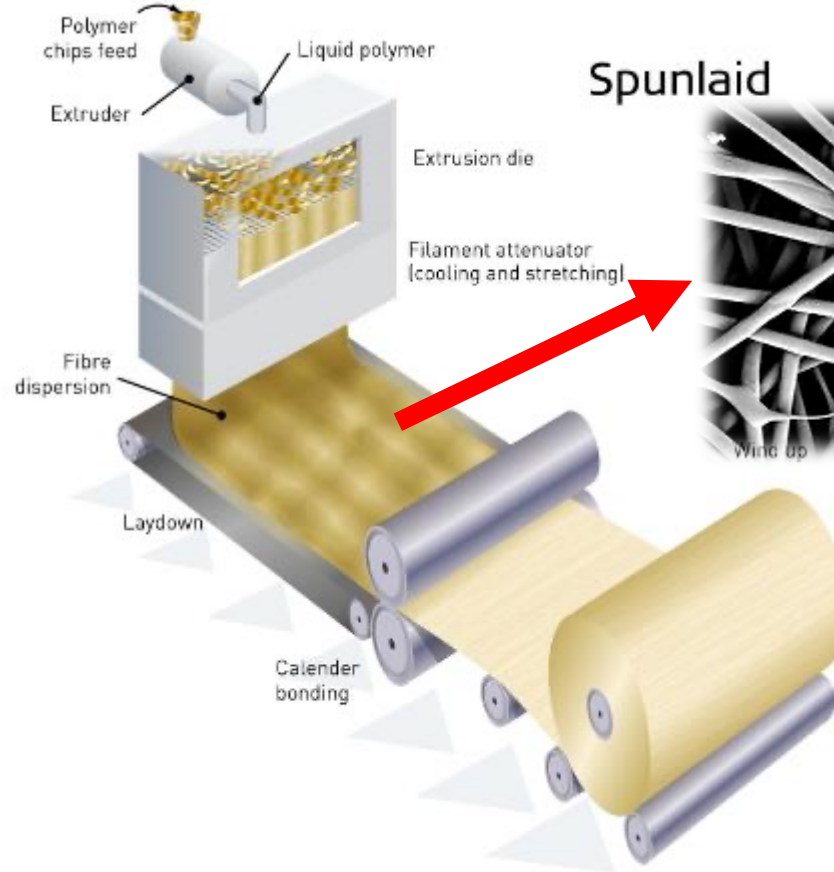
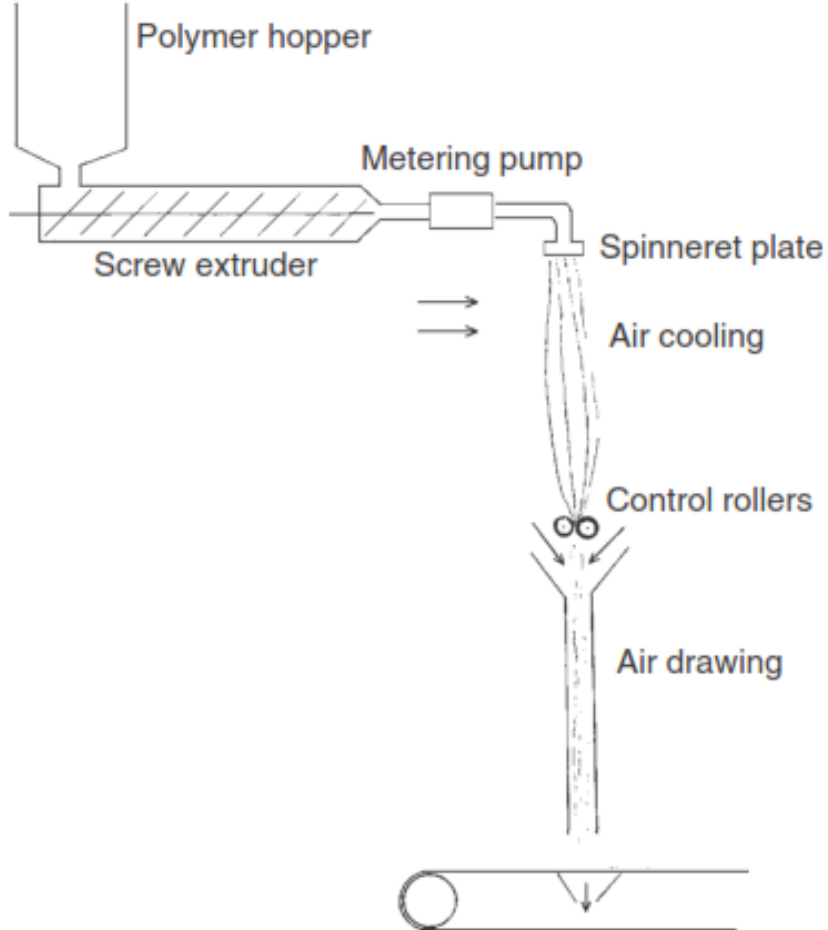

Spunlaid

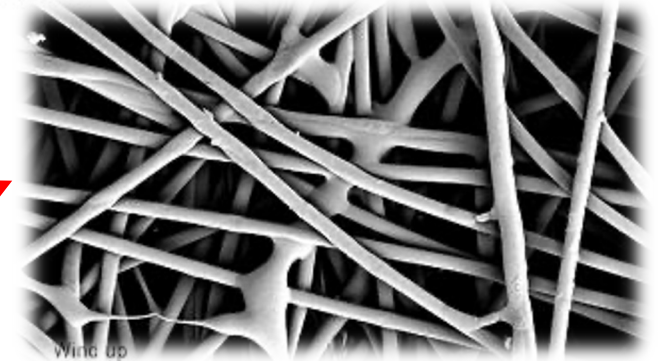

% share of India's Non wovens by Technology

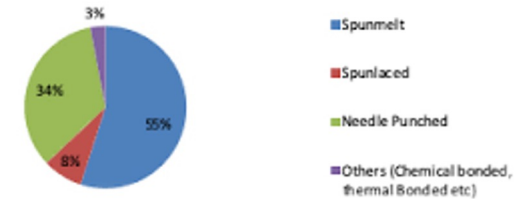

Flaş Eğirme



DOKUSUZ YÜZEYLER

Bu proje Avrupa Birliği ve Türkiye Cumhuriyeti tarafından finanse edilmektedir

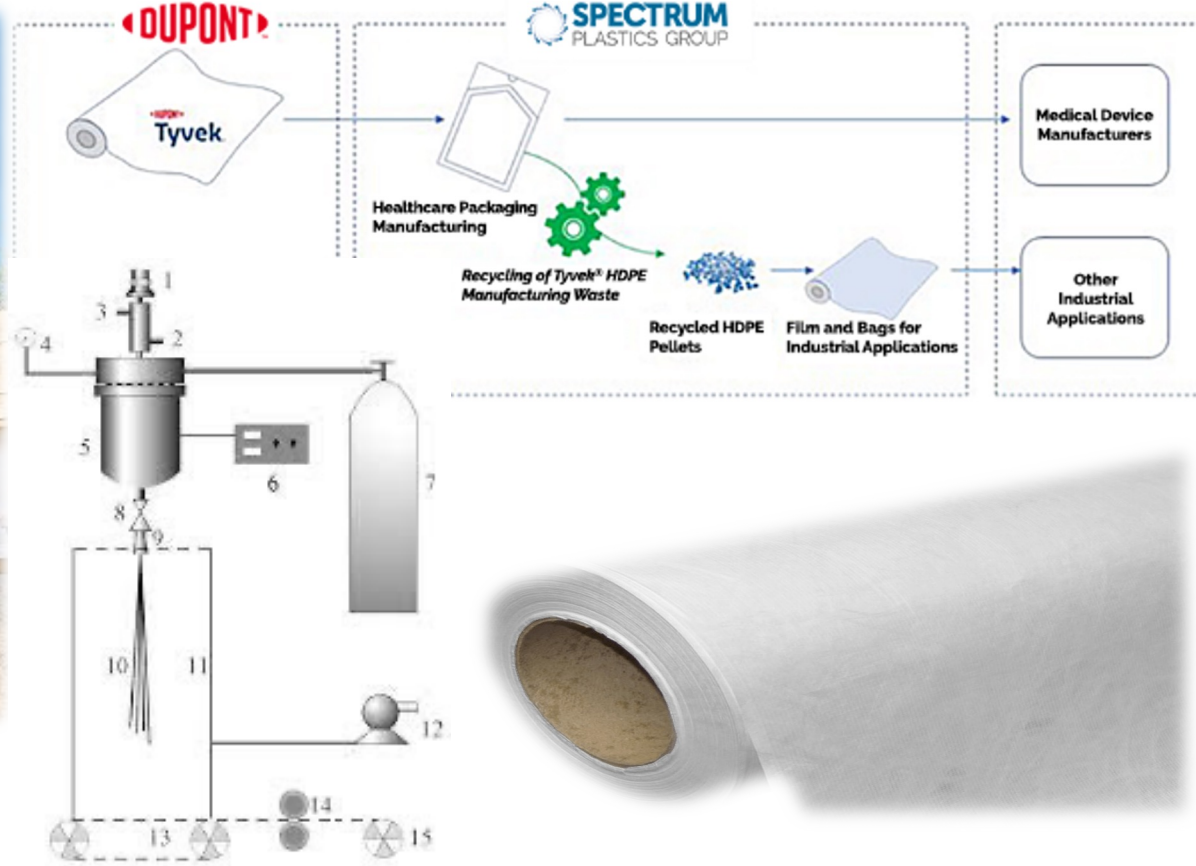

Eriyikten Püskürtme

Melt Blowing



Bu proje Avrupa Birliği ve Türkiye Cumhuriyeti tarafından finanse edilmektedir

DOKUSUZ YÜZEYLER

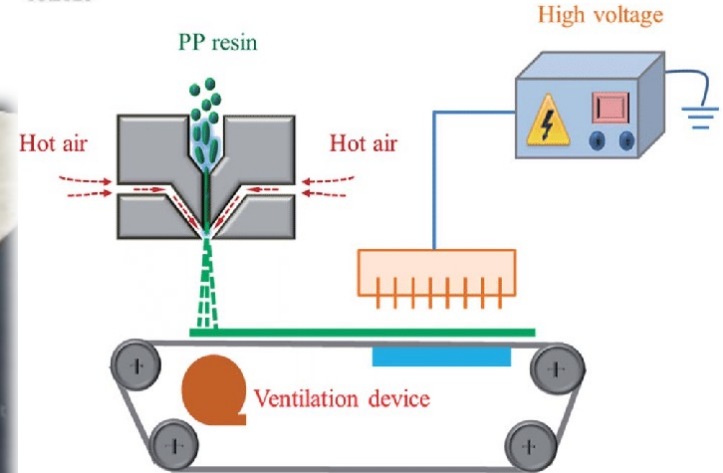
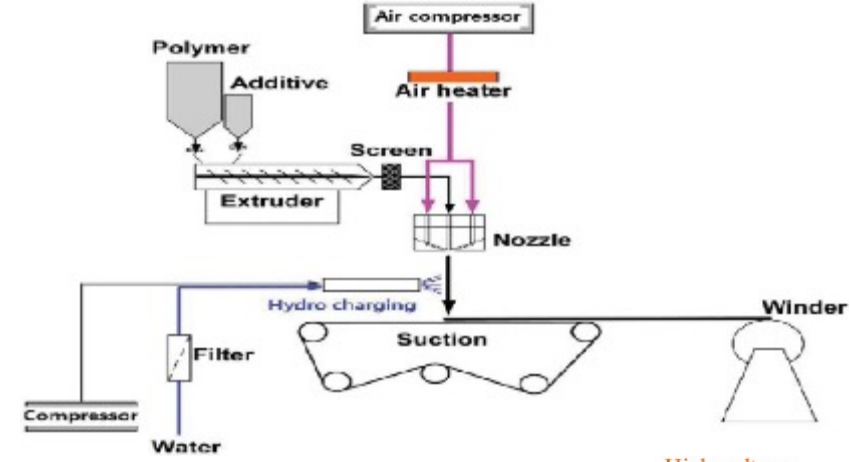
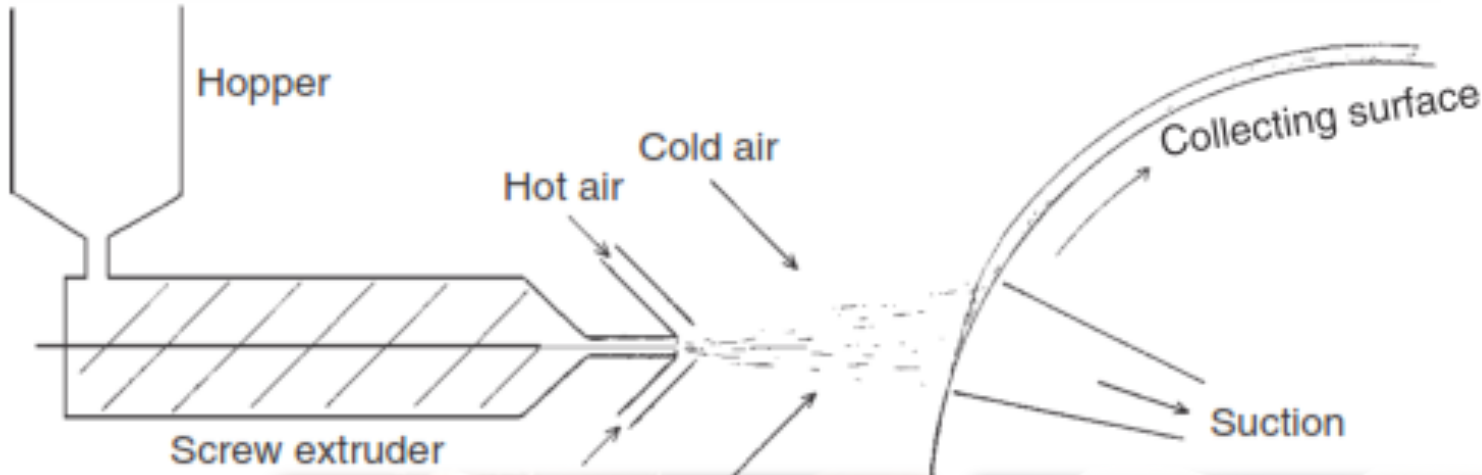

Kimyasal Yapıştırma



DOKUSUZ YÜZEYLER

Bu proje Avrupa Birliği ve Türkiye Cumhuriyeti tarafından finanse edilmektedir

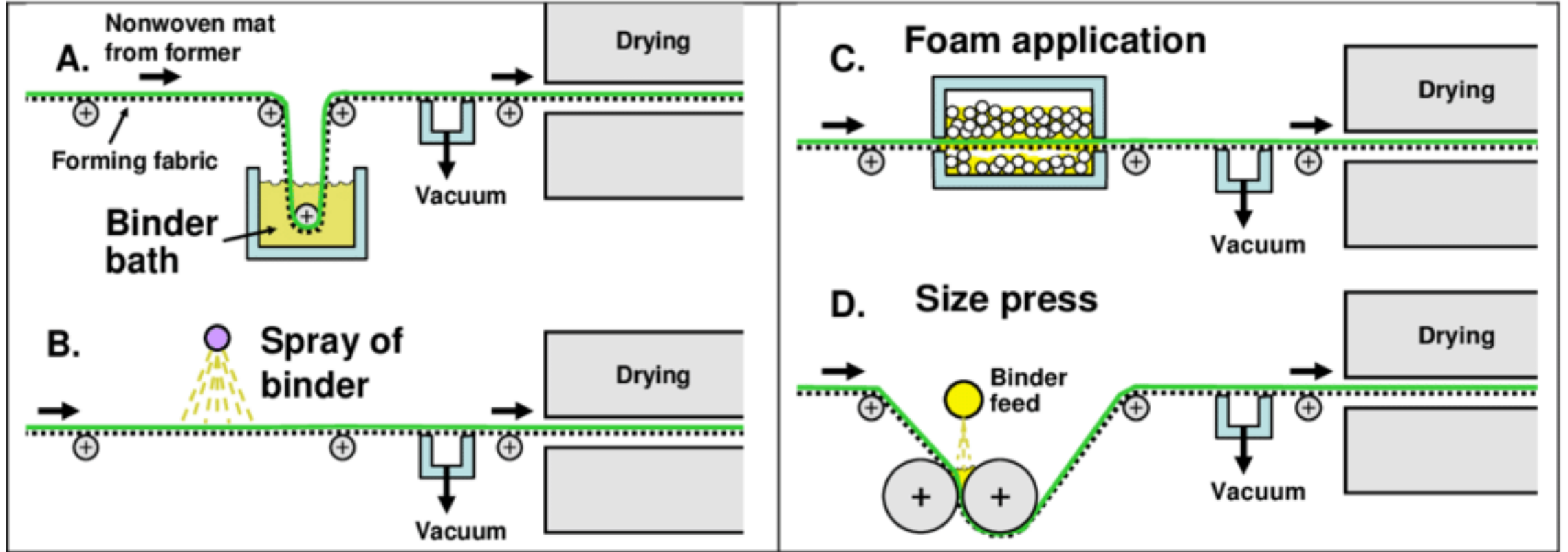

Kimyasal Yapıştırma

Köpük Emdirme



Bu proje Avrupa Birliği ve Türkiye Cumhuriyeti tarafından finanse edilmektedir

DOKUSUZ YÜZEYLER

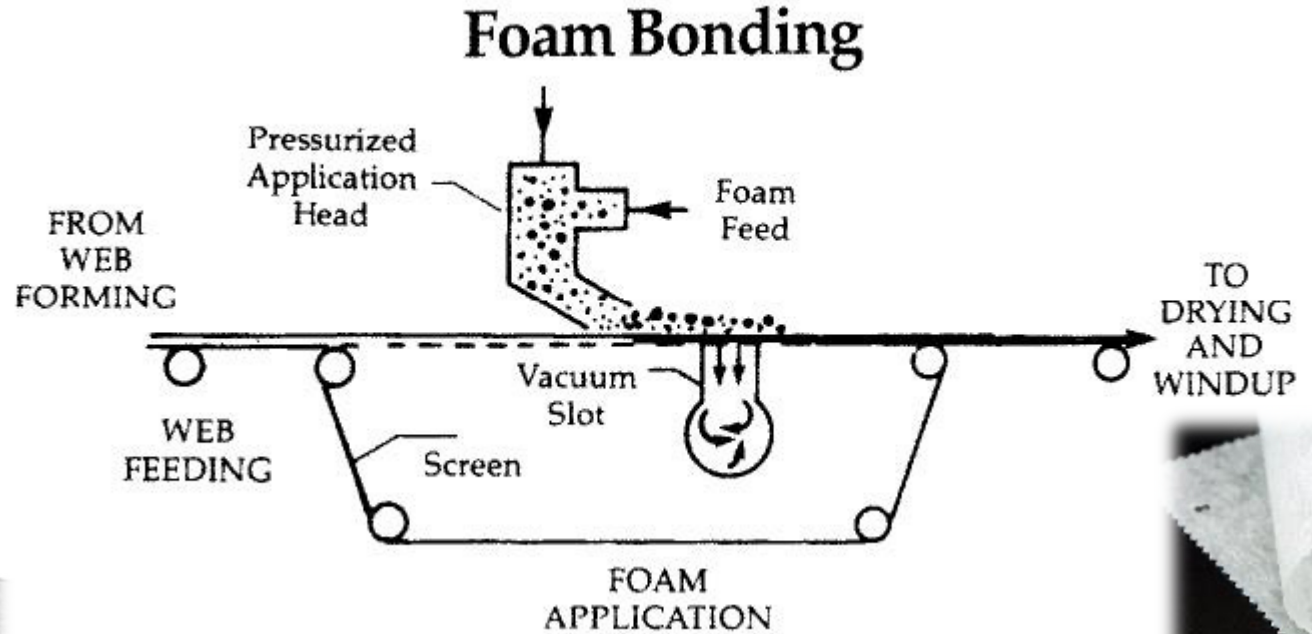

Kimyasal Yapıştırma

Baskı Yapıştırma



Bu proje Avrupa Birliği ve Türkiye Cumhuriyeti tarafından finanse edilmektedir

DOKUSUZ YÜZEYLER

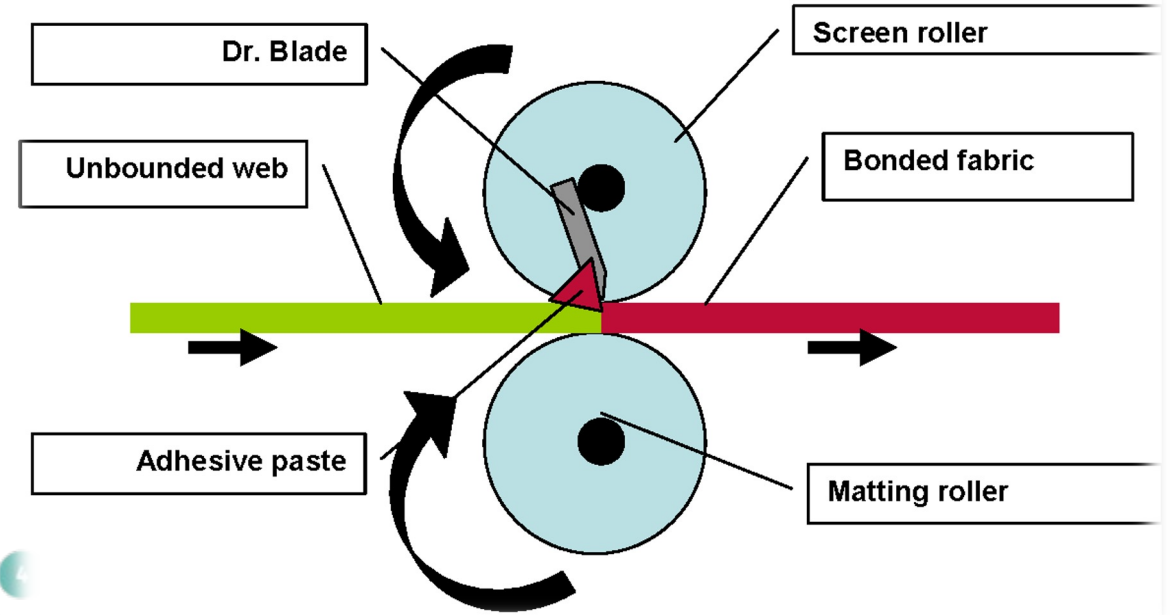
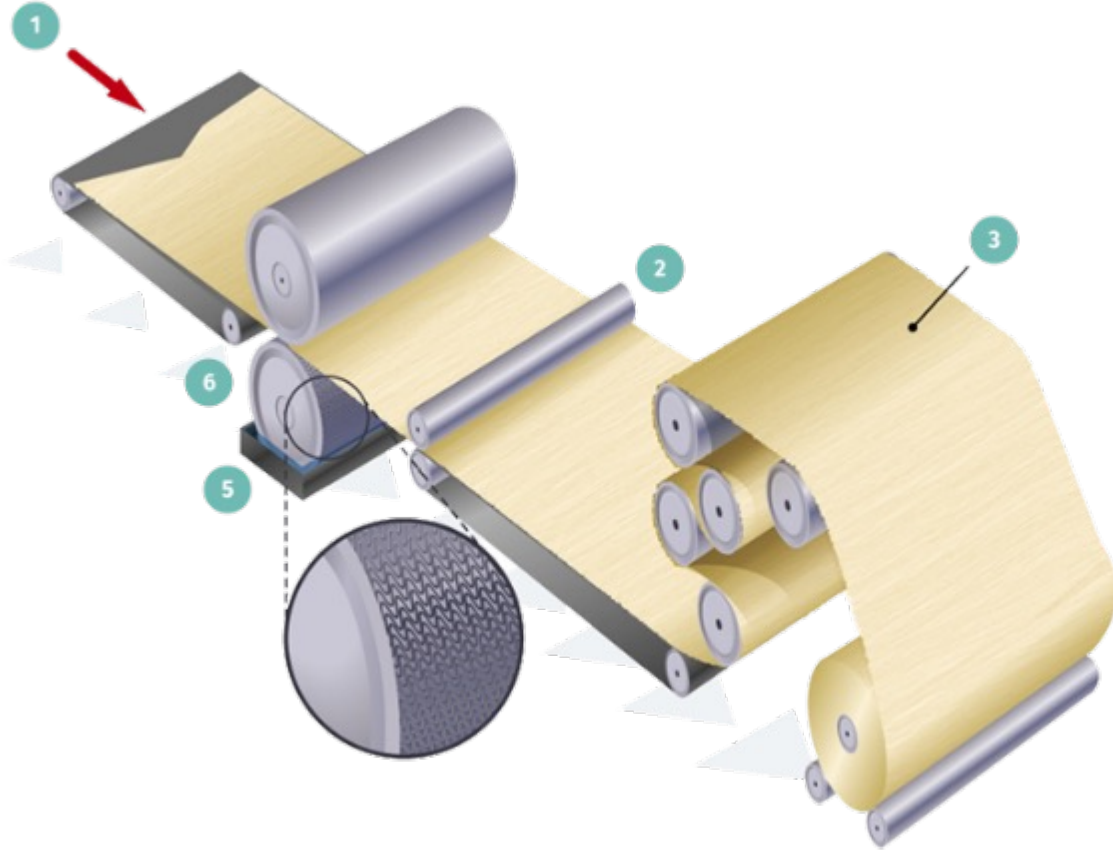

Termal Yapıştırma



Bu proje Avrupa Birliği ve Türkiye Cumhuriyeti tarafından finanse edilmektedir

DOKUSUZ YÜZEYLER

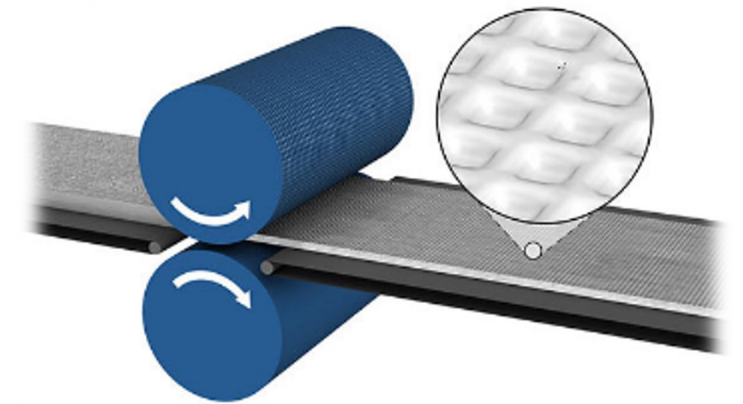
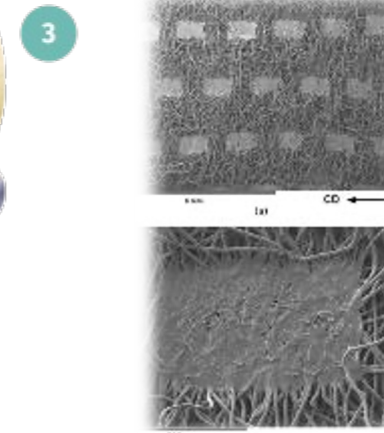
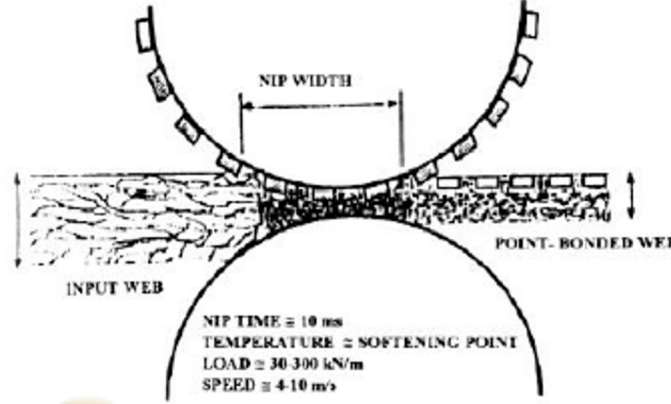
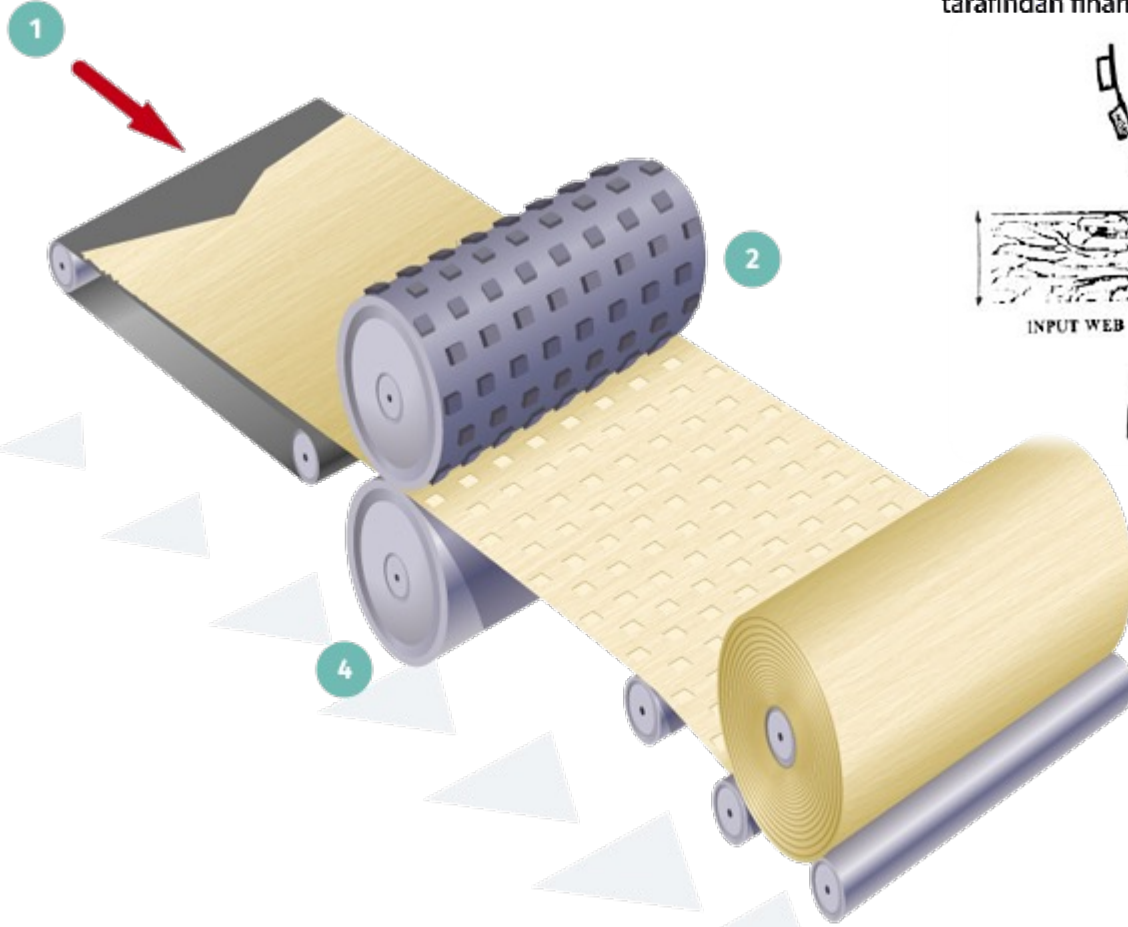

İğneleme



Bu proje Avrupa Birliği ve Türkiye Cumhuriyeti tarafından finanse edilmektedir

DOKUSUZ YÜZEYLER

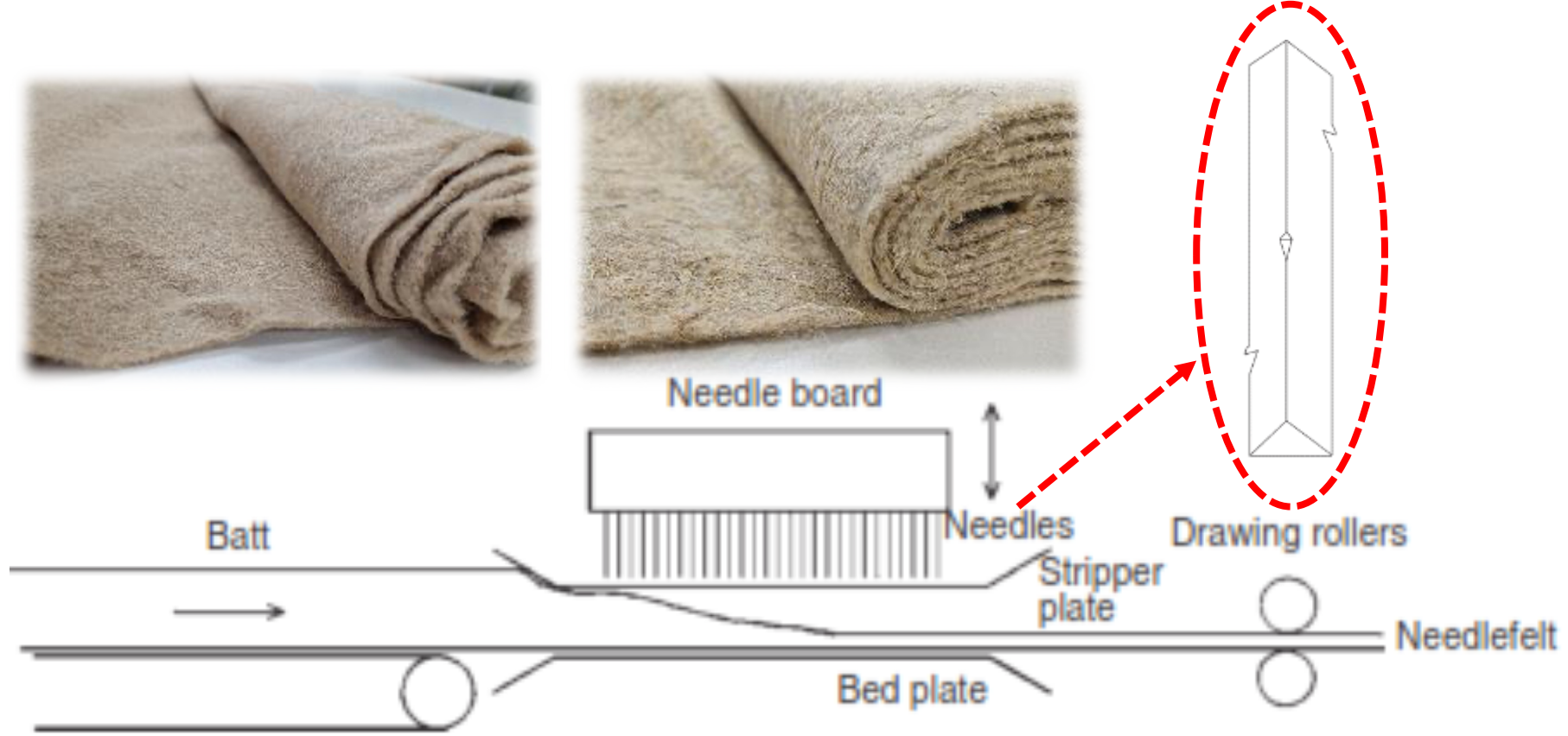

Dikiş Yapıştırma



Bu proje Avrupa Birliği ve Türkiye Cumhuriyeti tarafından finanse edilmektedir

DOKUSUZ YÜZEYLER

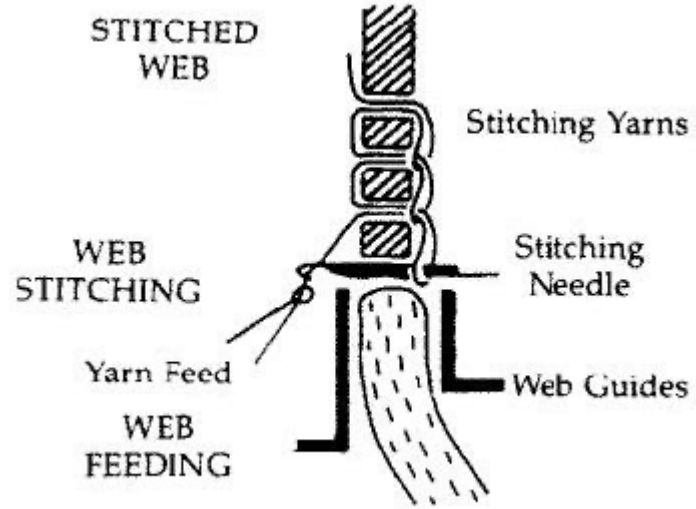

Stitchbond stage

1. penetration
2. lapping
3. closing
4. knocking-over
5. take-down

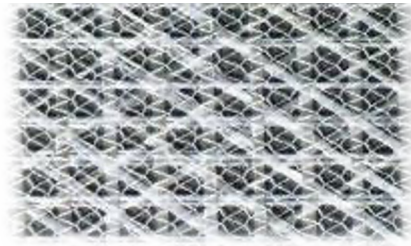
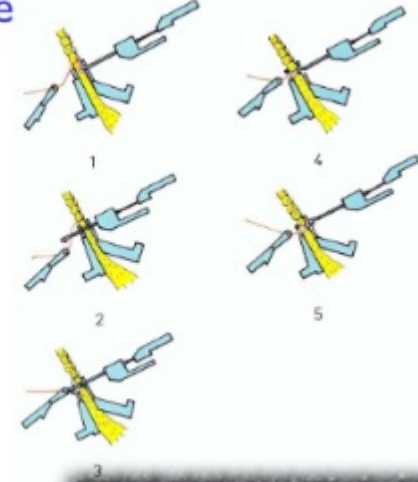

Fibre web

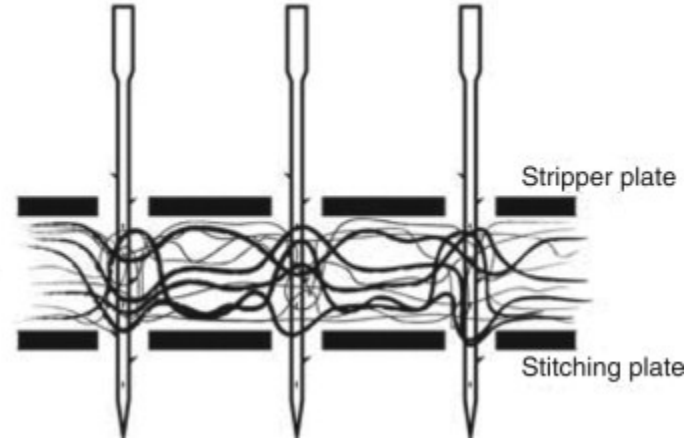

Hidro-Dolama



DOKUSUZ YÜZEYLER

Bu proje Avrupa Birliği ve Türkiye Cumhuriyeti tarafından finanse edilmektedir

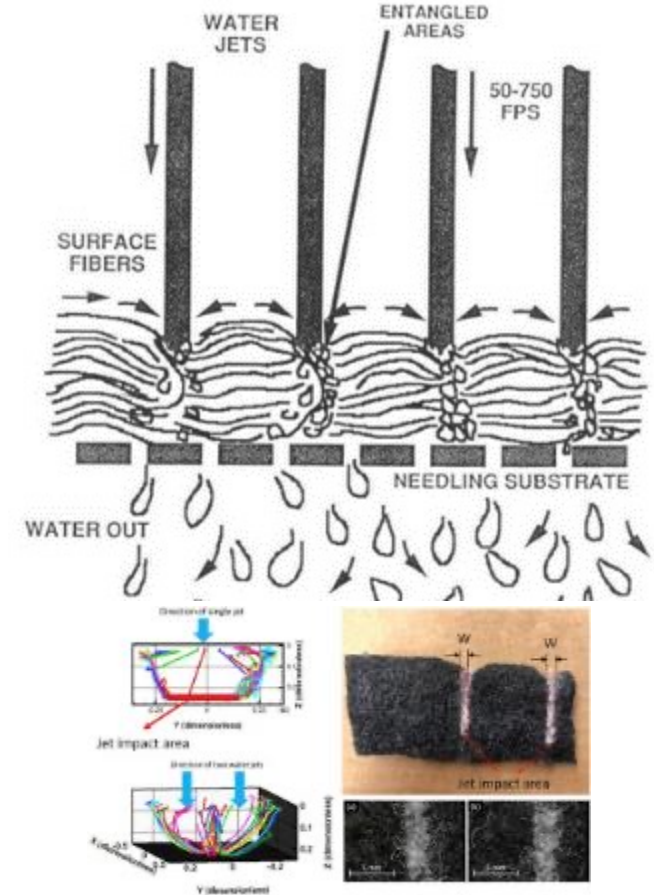
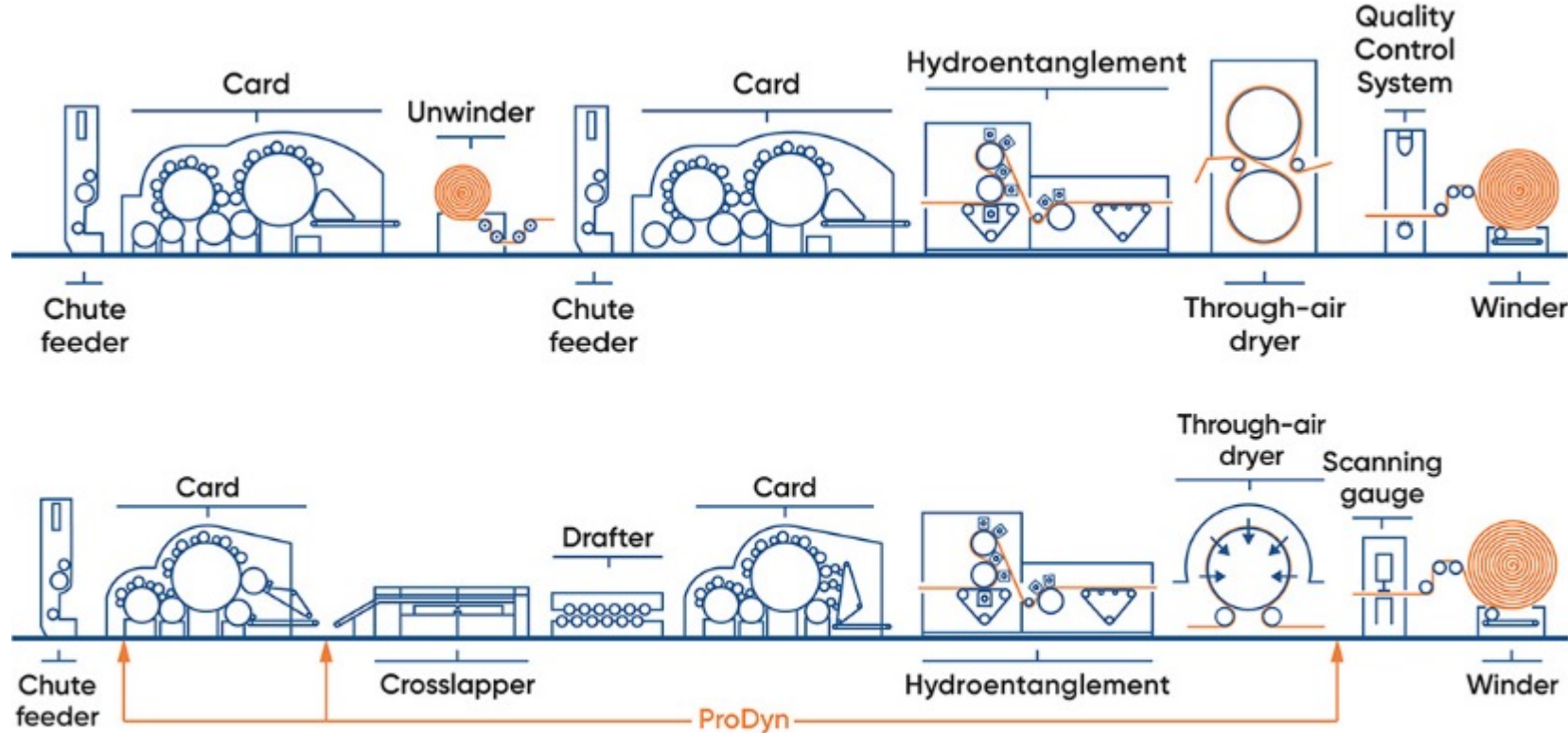



Bu proje Avrupa Birliđi ve Türkiye Cumhuriyeti tarafından finanse edilmektedir

7. Bölüm

BİTİM İŞLEMLERİ ve KAPLAMA



Ağızlık Açma Ped Batch



Bu proje Avrupa Birliği ve Türkiye Cumhuriyeti tarafından finanse edilmektedir

BİTİM İŞLEMLERİ ve KAPLAMA

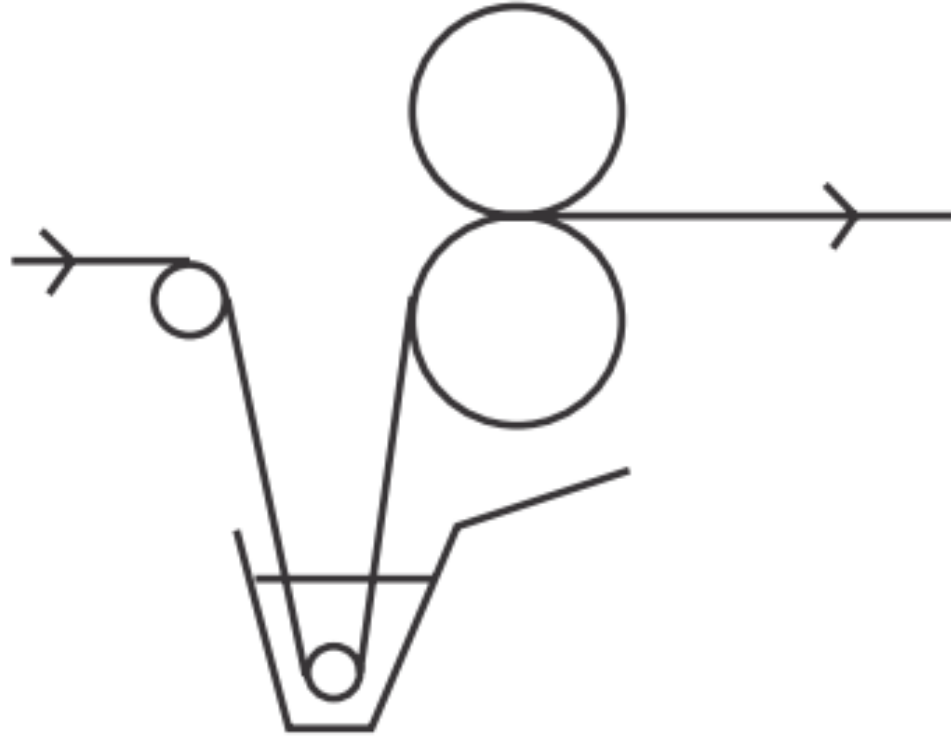

Pad mangle

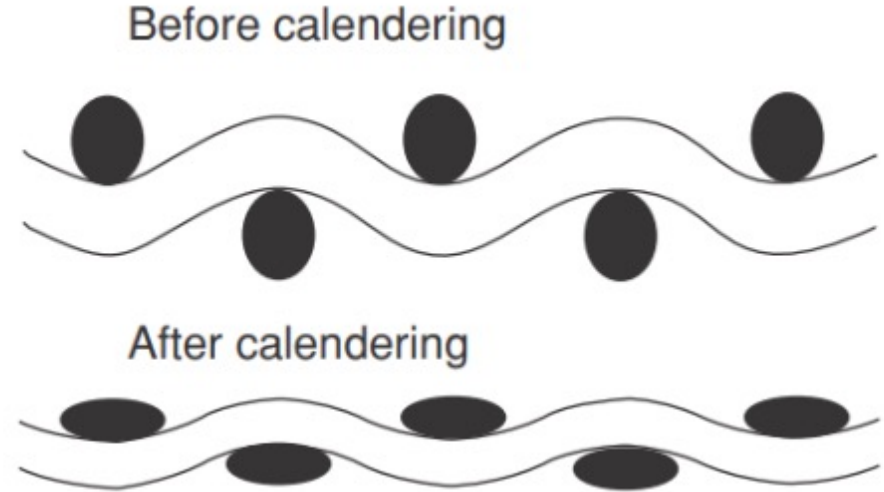

Kalenderleme



Bu proje Avrupa Birliđi ve Türkiye Cumhuriyeti tarafından finanse edilmektedir

BİTİM İŞLEMLERİ ve KAPLAMA

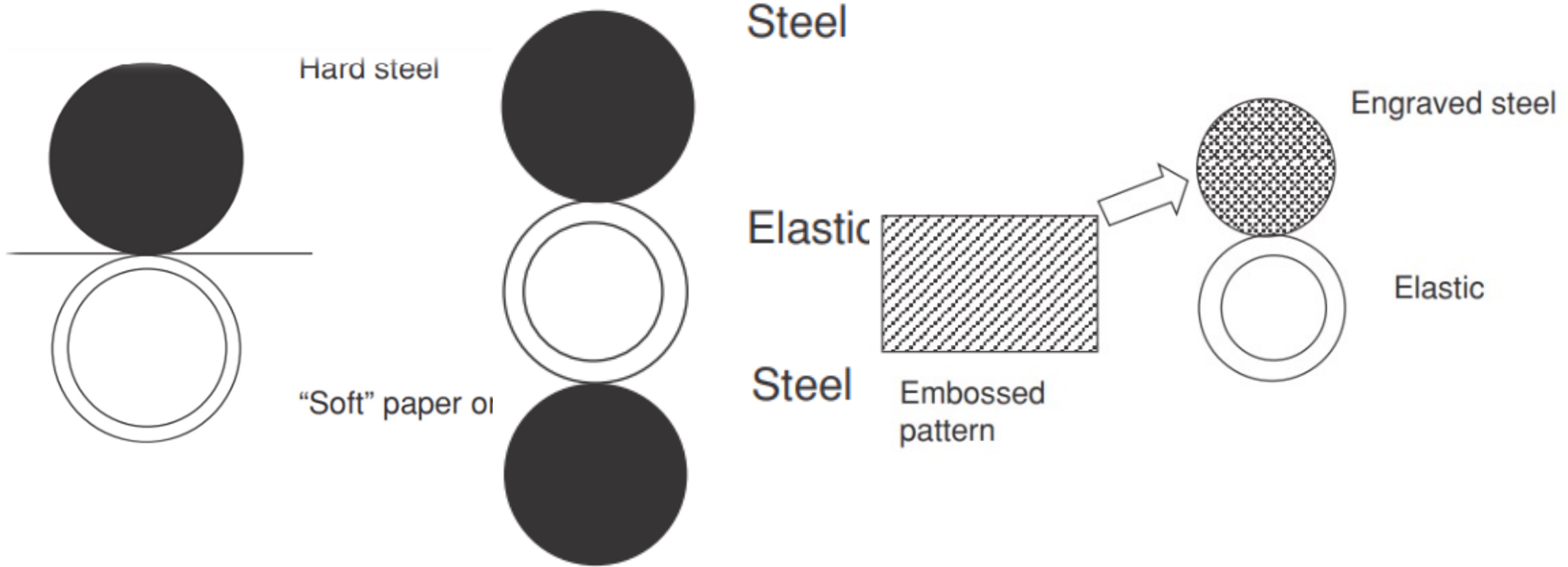

Şardonlama



BİTİM İŞLEMLERİ ve KAPLAMA

Bu proje Avrupa Birliği ve Türkiye Cumhuriyeti tarafından finanse edilmektedir

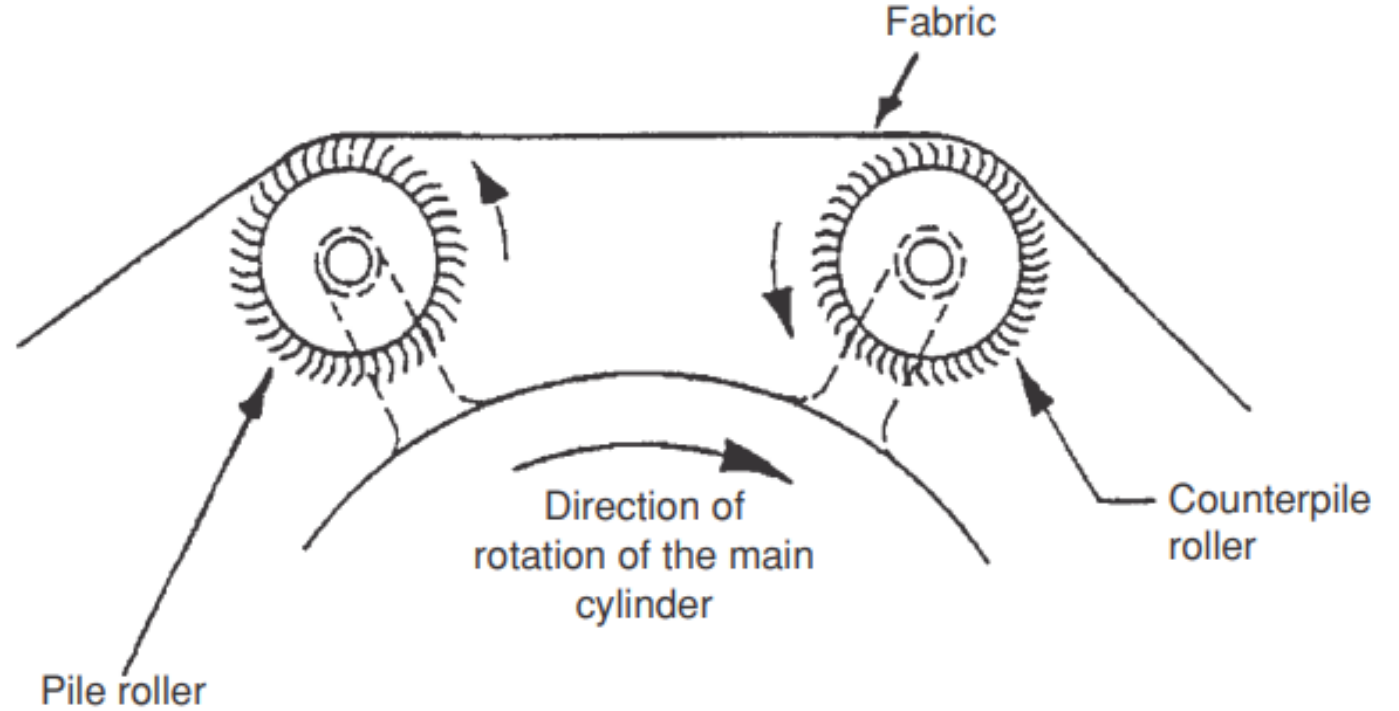
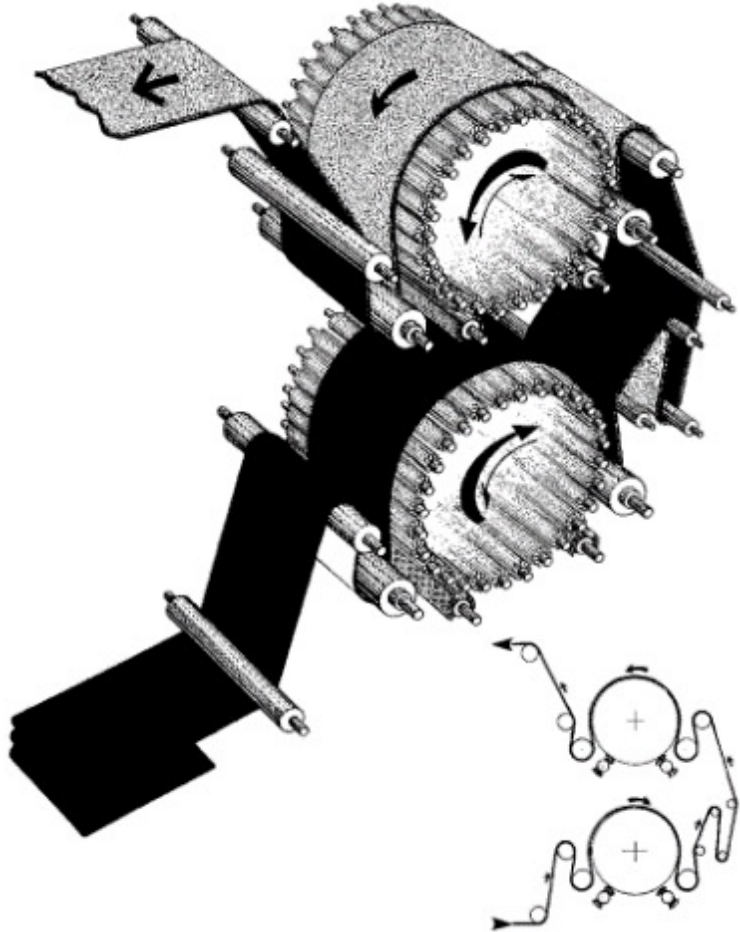

Makaslama



Bu proje Avrupa Birliđi ve Türkiye Cumhuriyeti tarafından finanse edilmektedir

BİTİM İŞLEMLERİ ve KAPLAMA

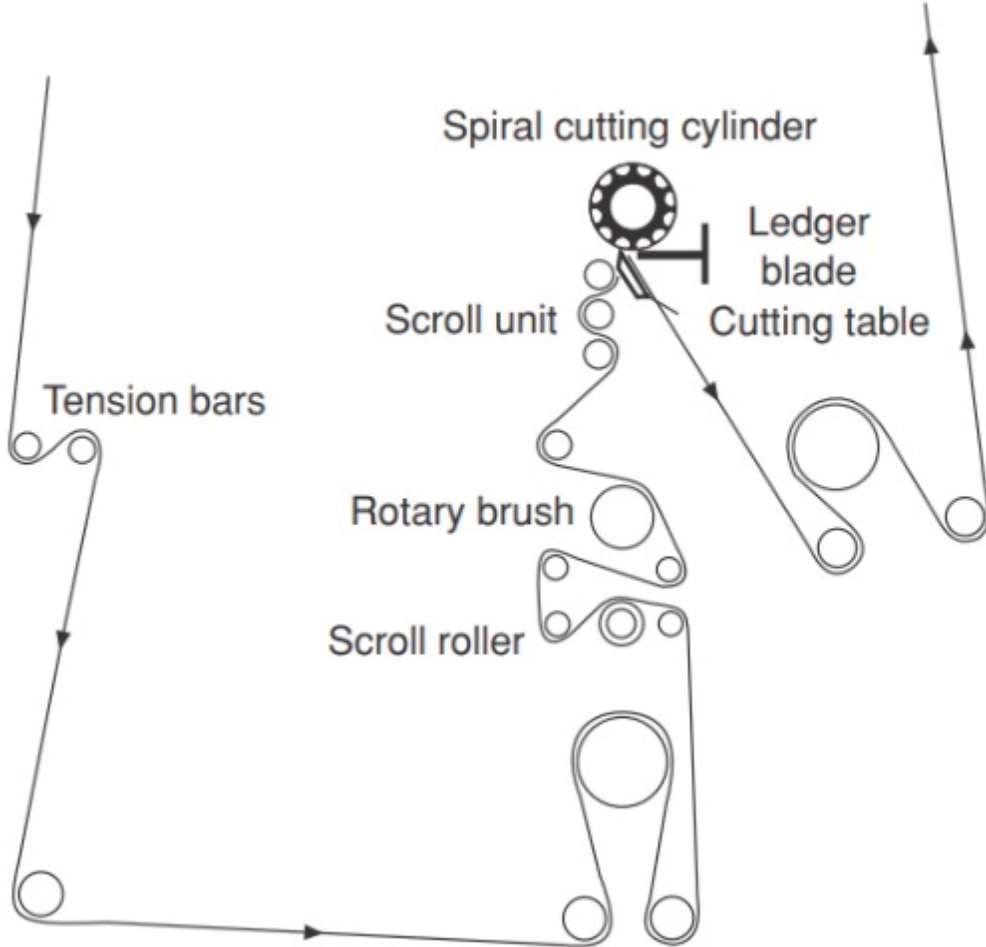

Sıkıştırılmalı Büzülme



Bu proje Avrupa Birliği ve Türkiye Cumhuriyeti tarafından finanse edilmektedir

BİTİM İŞLEMLERİ ve KAPLAMA

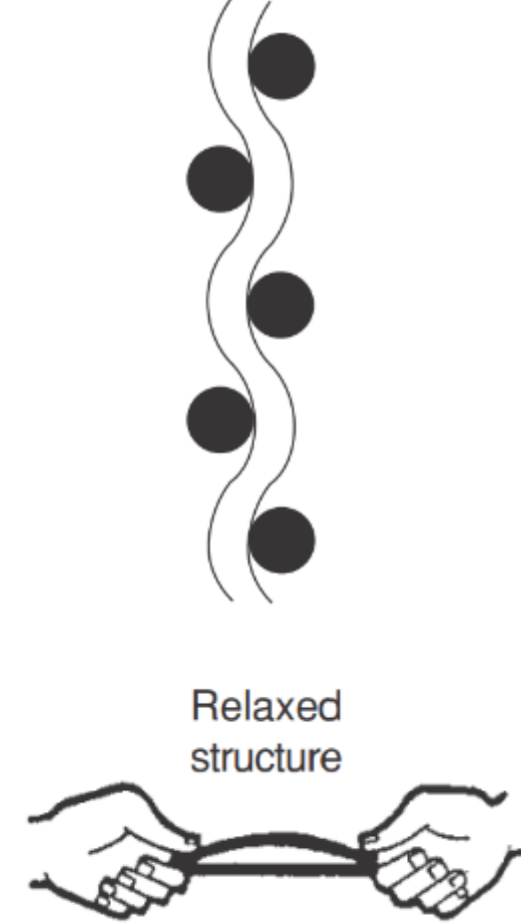
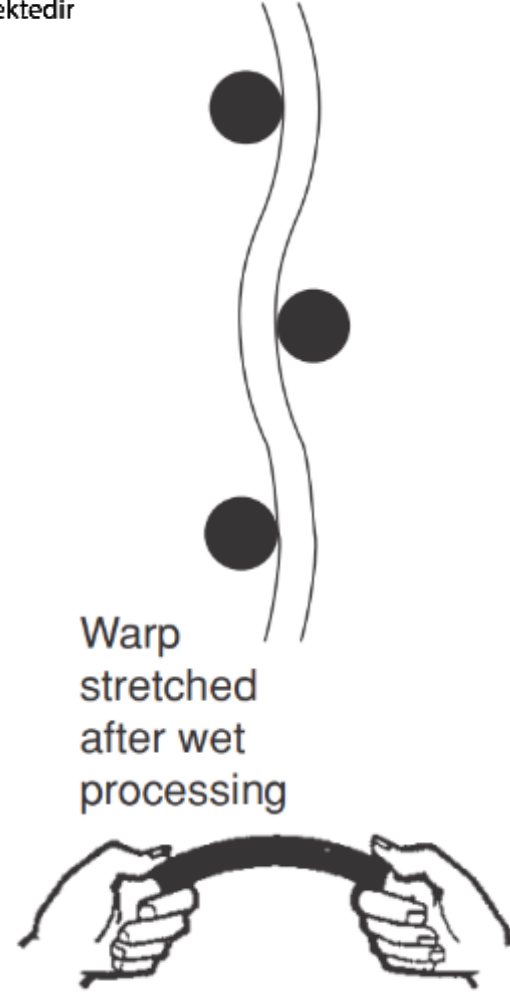
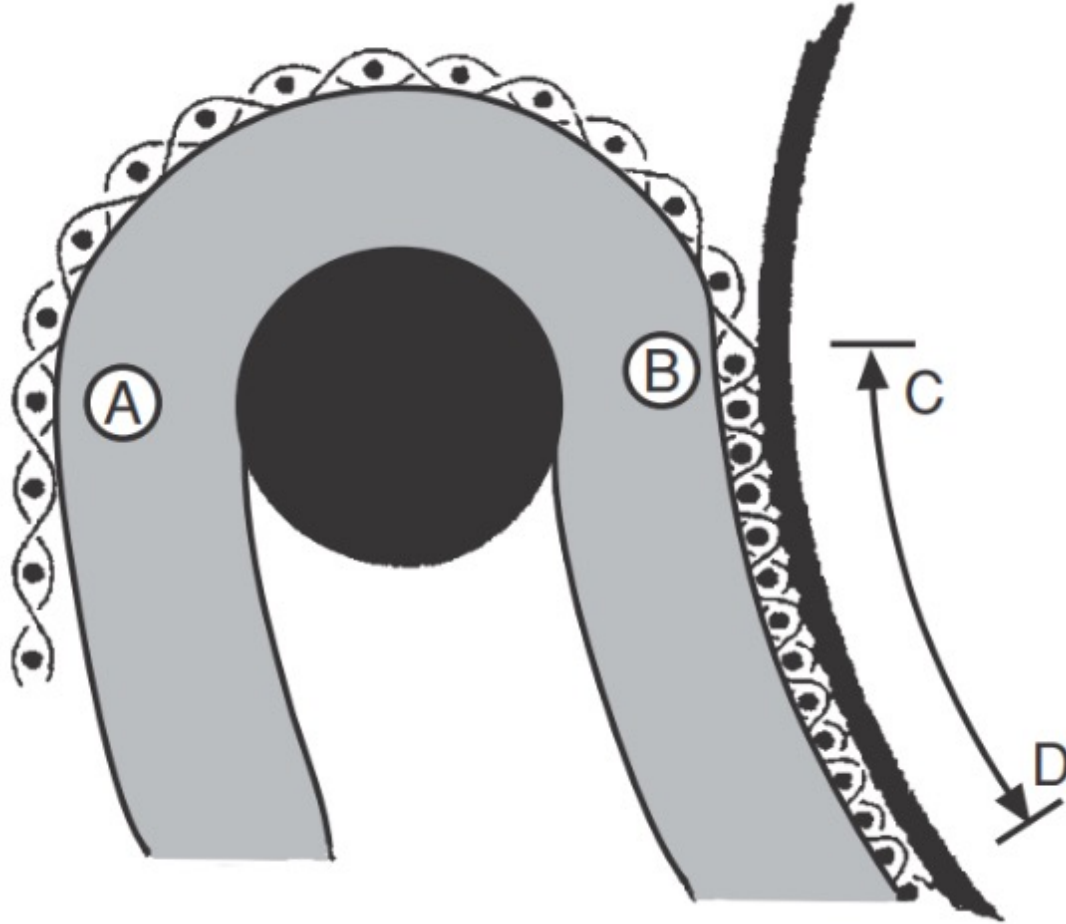

Sıkıştırılmalı Büzülme



BİTİM İŞLEMLERİ ve KAPLAMA

Bu proje Avrupa Birliği ve Türkiye Cumhuriyeti tarafından finanse edilmektedir

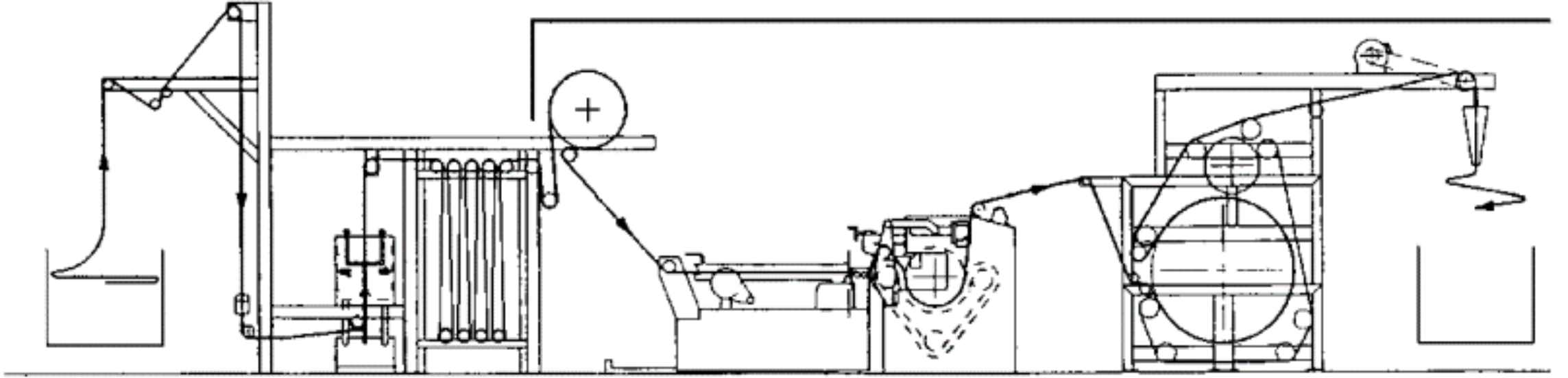

Isıl İşlem



BİTİM İŞLEMLERİ ve KAPLAMA

Bu proje Avrupa Birliği ve Türkiye Cumhuriyeti tarafından finanse edilmektedir

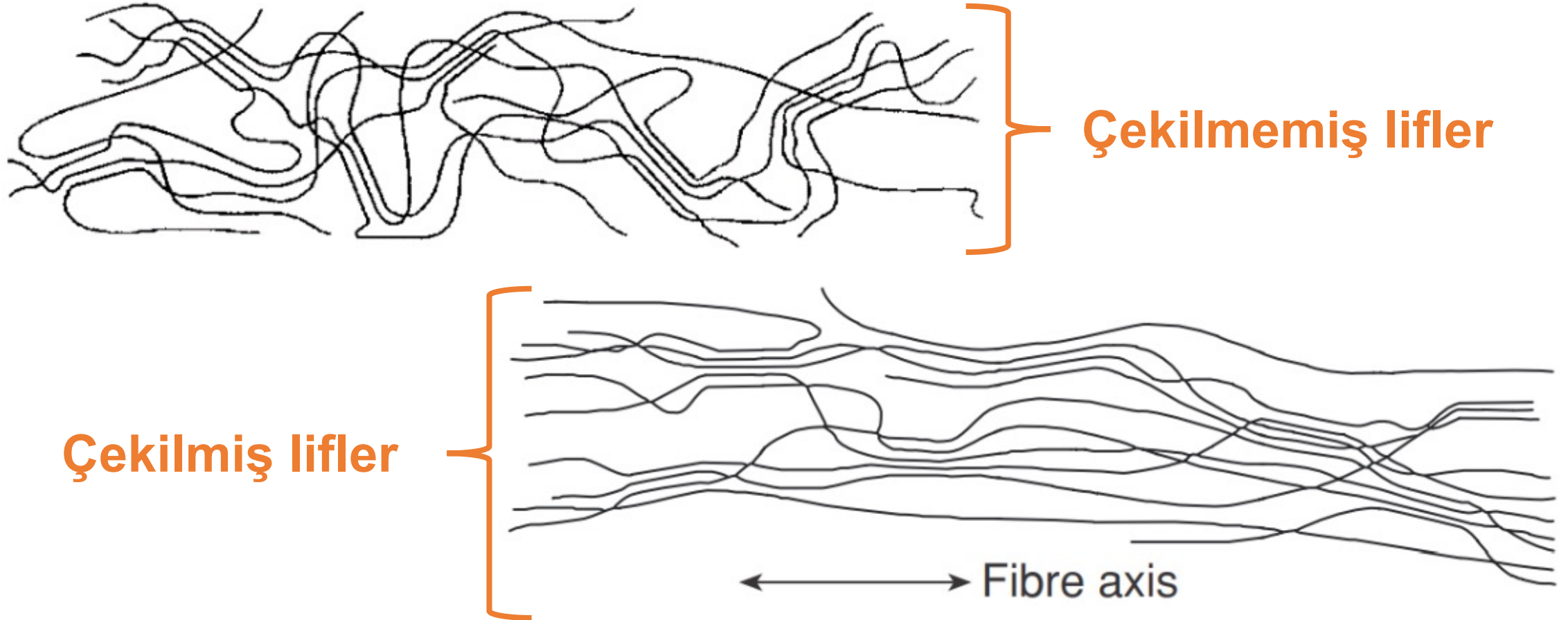

Kimyasal Bitim İşlemleri

Alev Geciktiricilik



Bu proje Avrupa Birliği ve Türkiye Cumhuriyeti tarafından finanse edilmektedir

BİTİM İŞLEMLERİ ve KAPLAMA

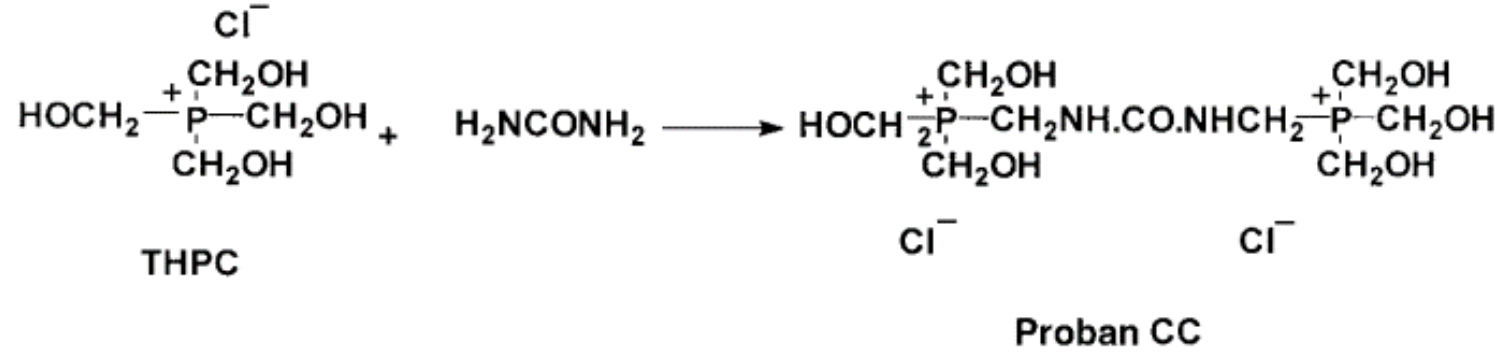

Proban Prosesi

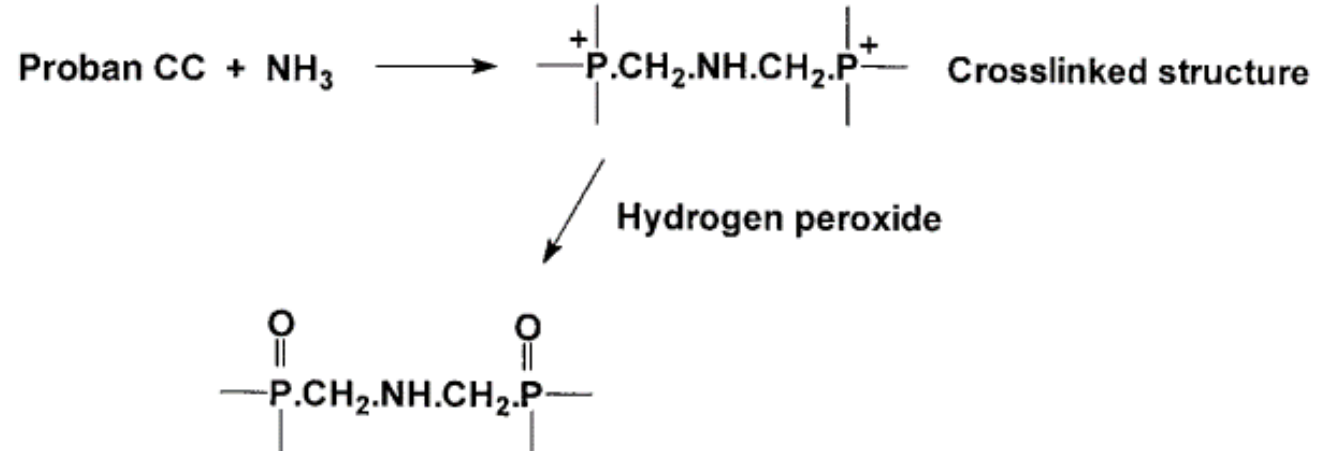

Kimyasal Bitim İşlemleri

Alev Geciktiricilik



Bu proje Avrupa Birliği ve Türkiye Cumhuriyeti tarafından finanse edilmektedir

BİTİM İŞLEMLERİ ve KAPLAMA

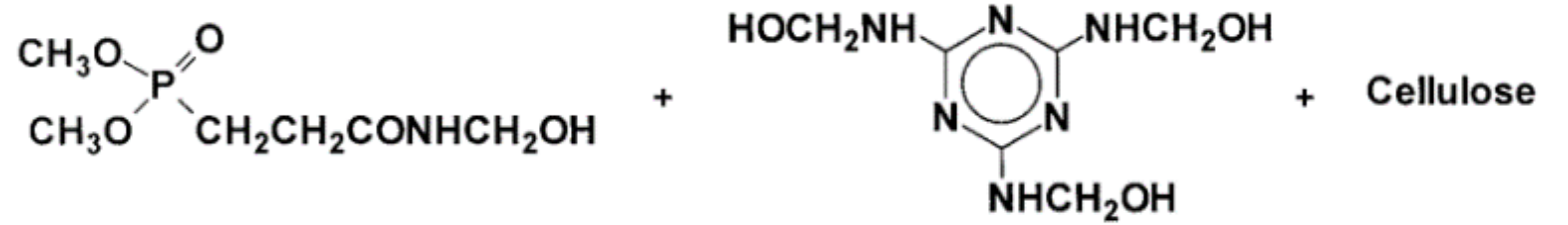

Pyrovatex

Trimethylol melamine

- H₂O

Acid catalysed

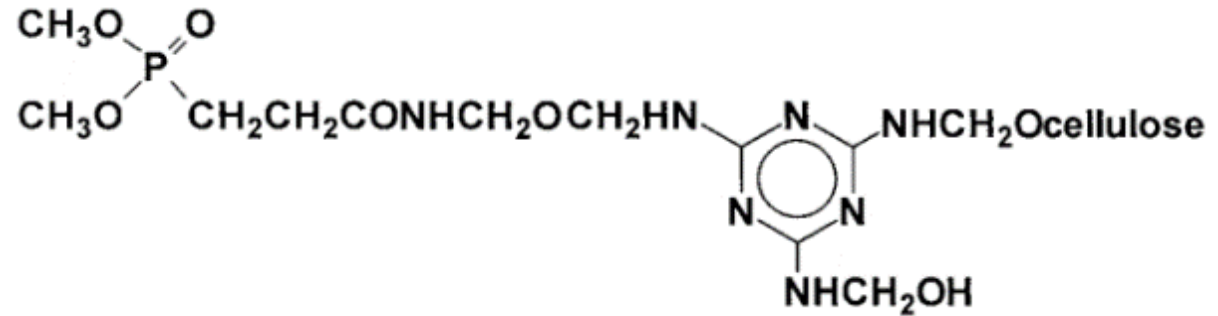

Pyrovatex Prosesi



Su İticilik Bitim İşlemi



BİTİM İŞLEMLERİ ve KAPLAMA

Bu proje Avrupa Birliği ve Türkiye Cumhuriyeti tarafından finanse edilmektedir

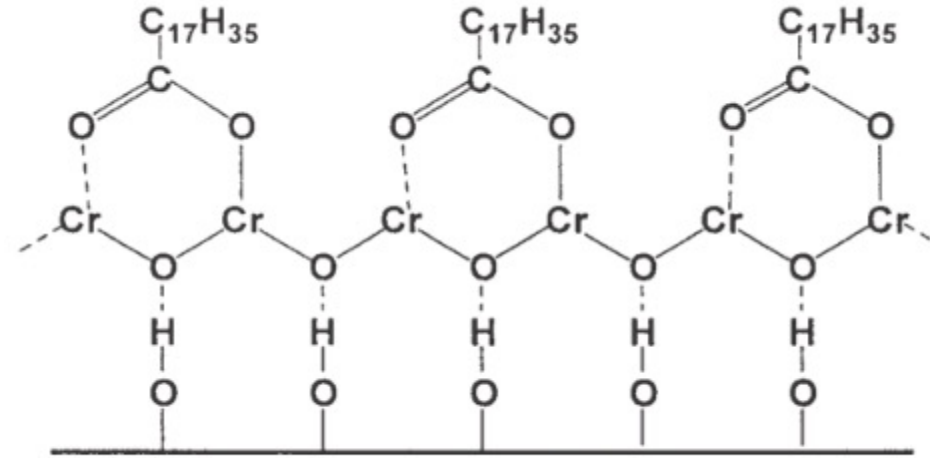

Cellulose surface with hydroxyl groups

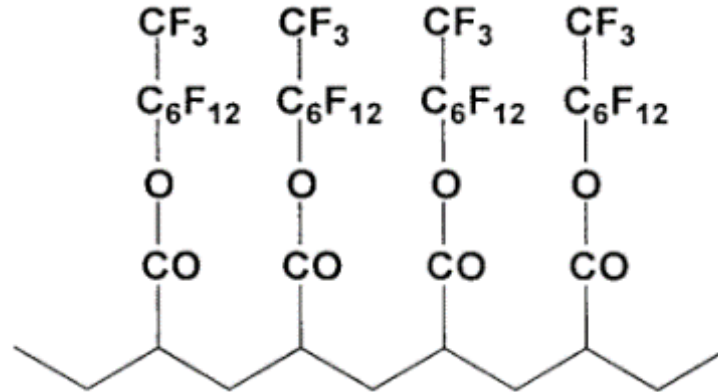

Methylol derivatives of fatty acid amides

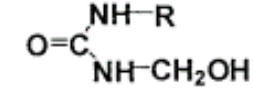

where R is a fatty acid, e.g. C₁₇H₃₅.CO

Pyridinium salts of fatty acids, for example

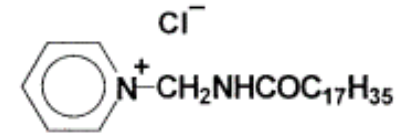

will react with cellulose

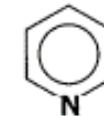
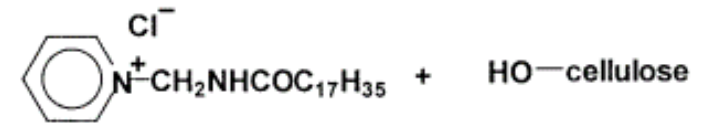

Su İtıcılık Bitim İşlemi



Bu proje Avrupa Birliđi ve Türkiye Cumhuriyeti tarafından finanse edilmektedir

BİTİM İŞLEMLERİ ve KAPLAMA

Finish	Application method	Trade names
Paraffin wax emulsion Paraffin wax plus Al or Cr salt	Spray As above but lower amounts	Mystoline, Ramasit Mystoline
Metal soap plus fatty acid Methylol stearamide	Pad, dry, bake Reactive resin, pad, dry, bake	Persistol Phobotex
Pyridinium compounds Reactive silicone resins Fluorocarbon emulsion	Pad, dry, bake Pad, dry, bake Pad, dry, bake	Velan (ICI), Zelan (Du Pont) Silicone Finish (ICI) Zepel (Du Pont), Scotchgard (3M)



Antistatiklik Bitim İşlemi



Bu proje Avrupa Birliği ve Türkiye Cumhuriyeti tarafından finanse edilmektedir

BİTİM İŞLEMLERİ ve KAPLAMA



Positive end

Polyurethane

Nylon

Wool

Silk

Rayon and cotton

Acetate

Polypropylene

Polyester

Acrylic

PVC (polyvinylchloride)

PTFE (polytetrafluoroethylene)

Negative end

Material at the top of series

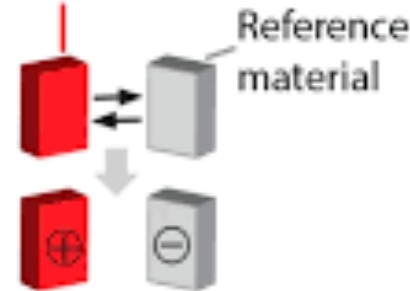

Material at the bottom of series

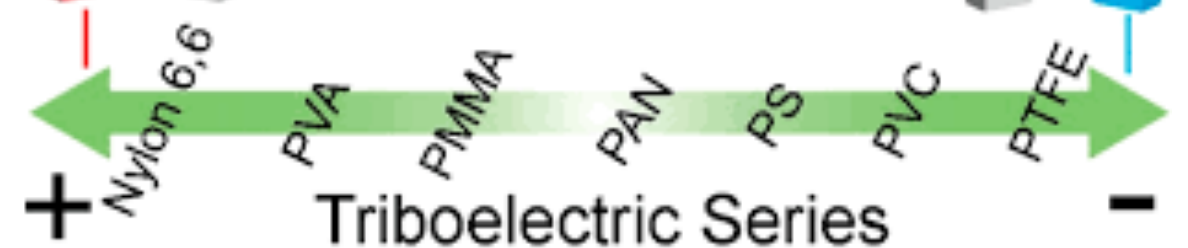
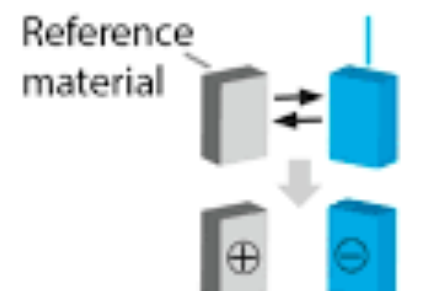

Antimikrobiyellik Bitim İşlemi



BİTİM İŞLEMLERİ ve KAPLAMA

Bu proje Avrupa Birliği ve Türkiye Cumhuriyeti tarafından finanse edilmektedir

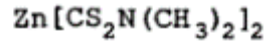

Zinc dimethyldithiocarbamate

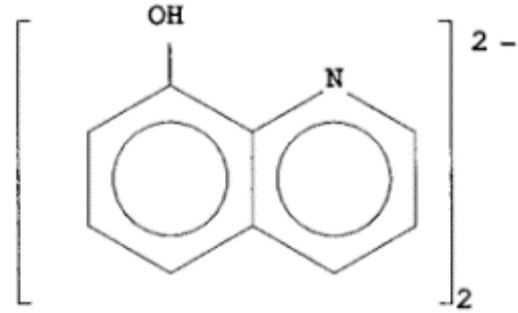

Copper 8-hydroxyquinolate

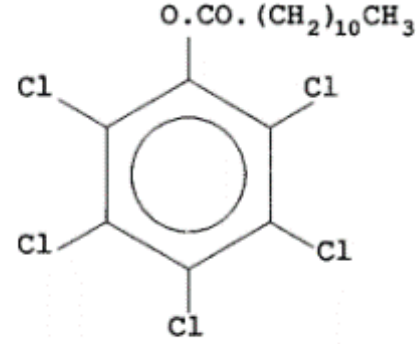

Pentachlorophenyl laurate

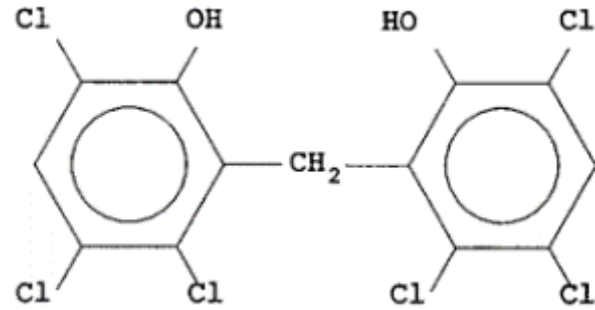

Hexachlorophene



Polimer Türleri



BİTİM İŞLEMLERİ ve KAPLAMA

Bu proje Avrupa Birliği ve Türkiye Cumhuriyeti tarafından finanse edilmektedir

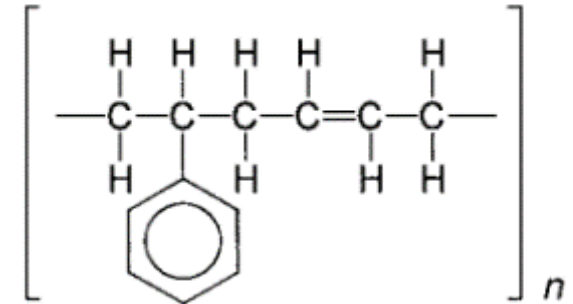
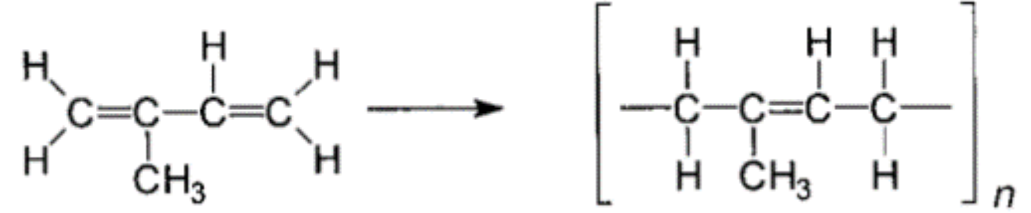
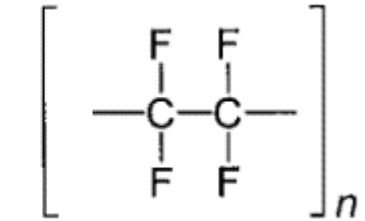
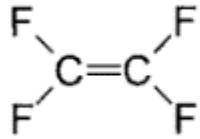
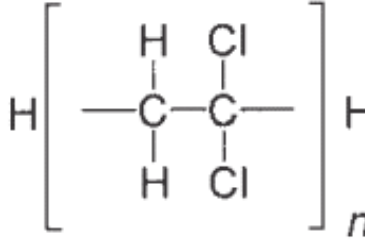
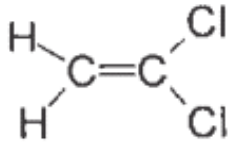
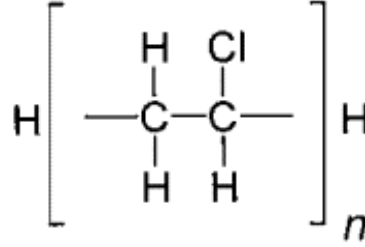
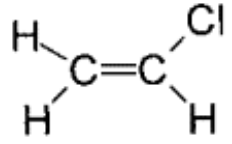

Polimer Türleri



Bu proje Avrupa Birliği ve Türkiye Cumhuriyeti tarafından finanse edilmektedir

BİTİM İŞLEMLERİ ve KAPLAMA

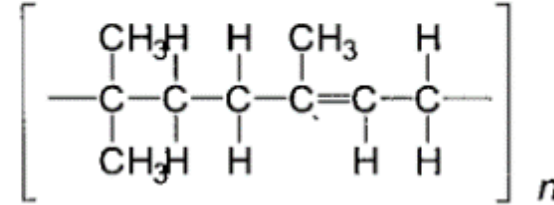
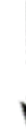
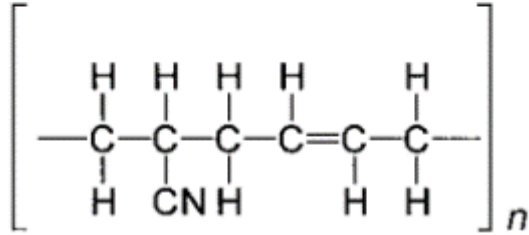

Polimer Türleri



Bu proje Avrupa Birliği ve Türkiye Cumhuriyeti tarafından finanse edilmektedir

BİTİM İŞLEMLERİ ve KAPLAMA

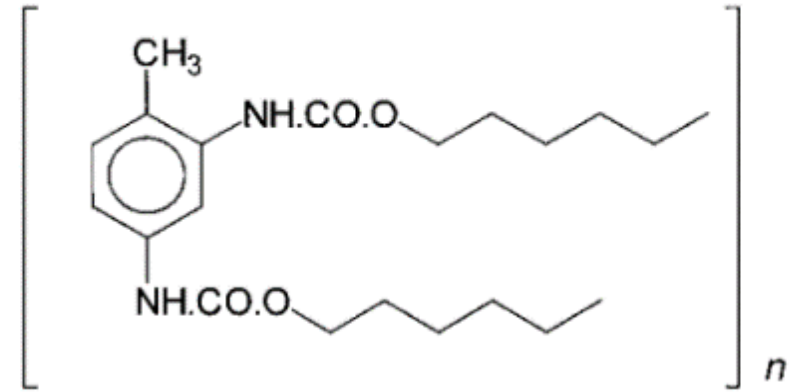
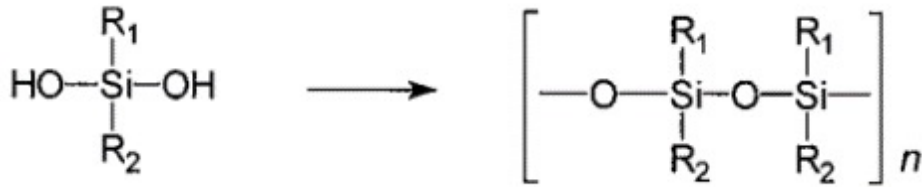
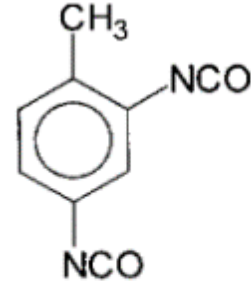
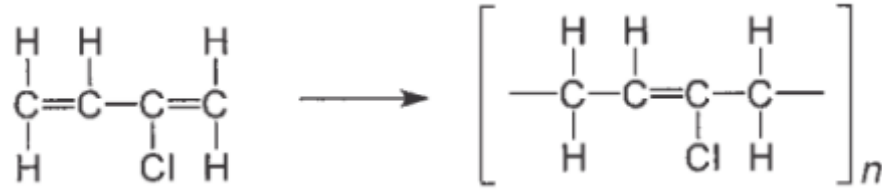

Yalama Kaplama



Bu proje Avrupa Birliđi ve Türkiye Cumhuriyeti tarafından finanse edilmektedir

BİTİM İŞLEMLERİ ve KAPLAMA

Yalama Kaplama

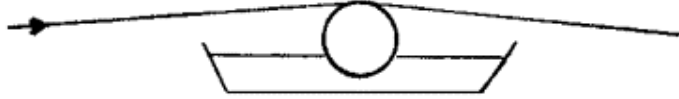

Silindir Kontrollü Yalama Kaplama



Bıçak Kontrollü Yalama Kaplama



Bıçakla Kaplama



Bu proje Avrupa Birliği ve Türkiye Cumhuriyeti tarafından finanse edilmektedir

BİTİM İŞLEMLERİ ve KAPLAMA

Bıçak türleri

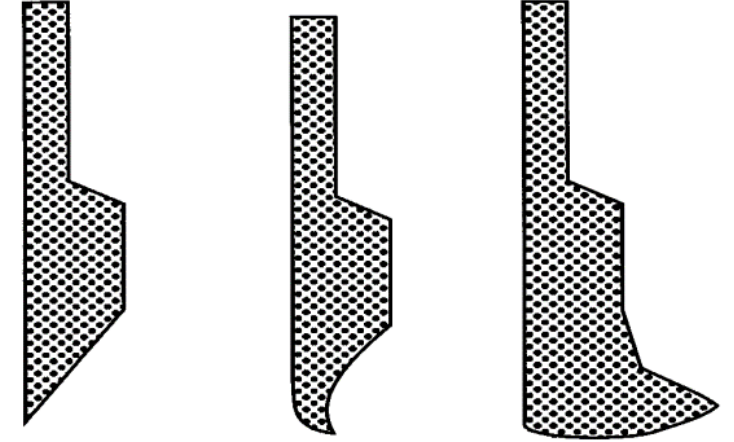

Havada Bıçak Kaplama

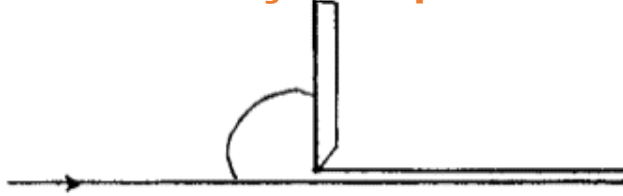

Tablada Bıçak Kaplama

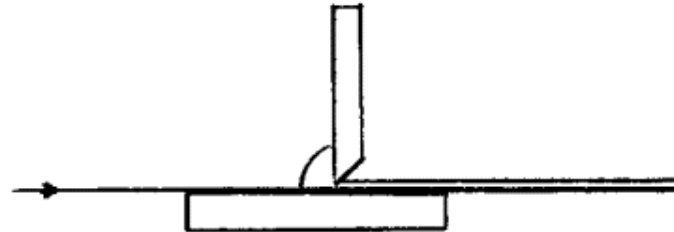

Örtü Üstünde Bıçakla Kaplama

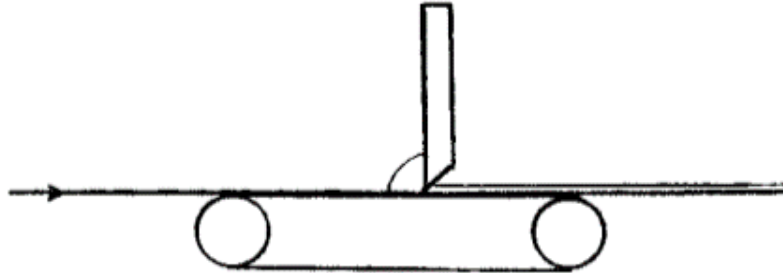

Silindirde Bıçak Kaplama

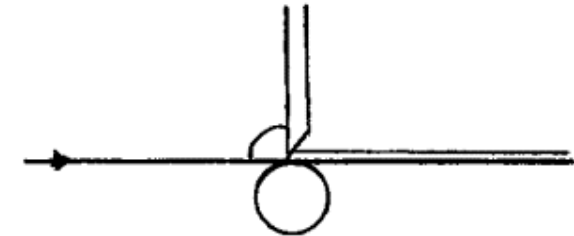

Gravür Kaplama



Bu proje Avrupa Birliği ve Türkiye Cumhuriyeti tarafından finanse edilmektedir

BİTİM İŞLEMLERİ ve KAPLAMA

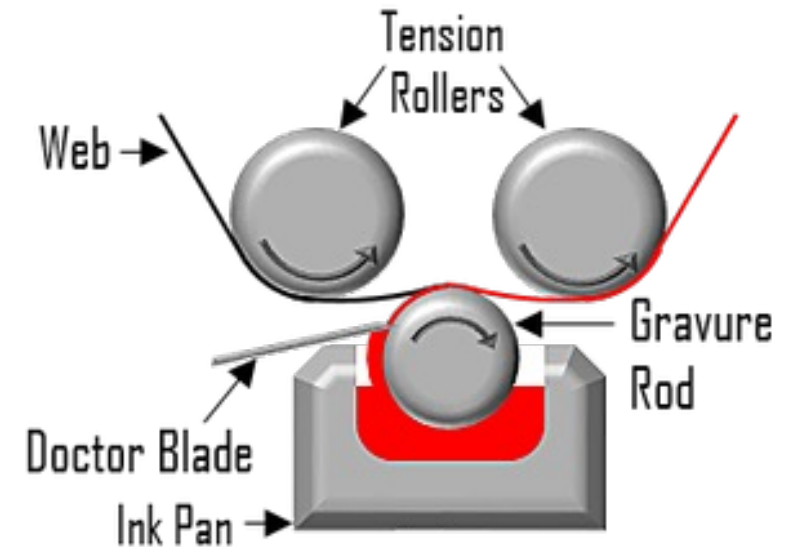
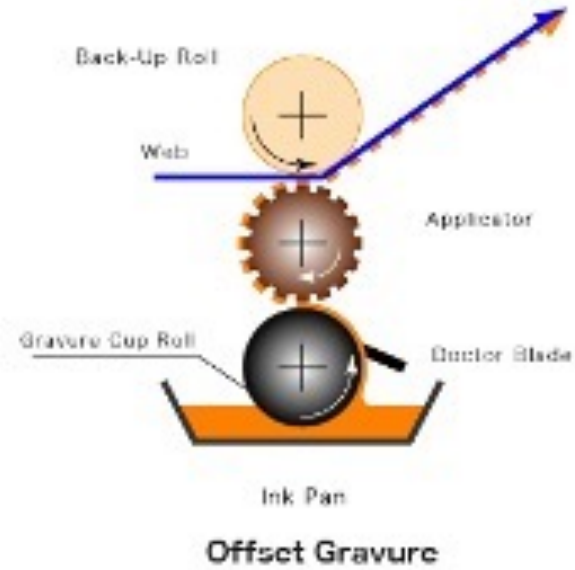
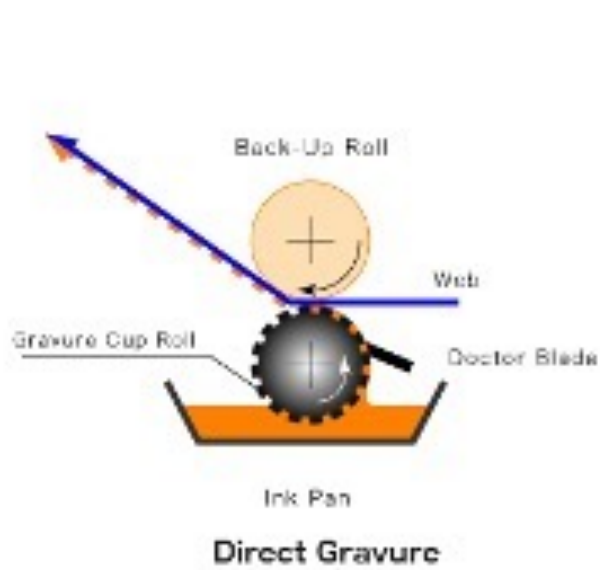

Döner Elek Kaplama



BİTİM İŞLEMLERİ ve KAPLAMA

Bu proje Avrupa Birliği ve Türkiye Cumhuriyeti tarafından finanse edilmektedir

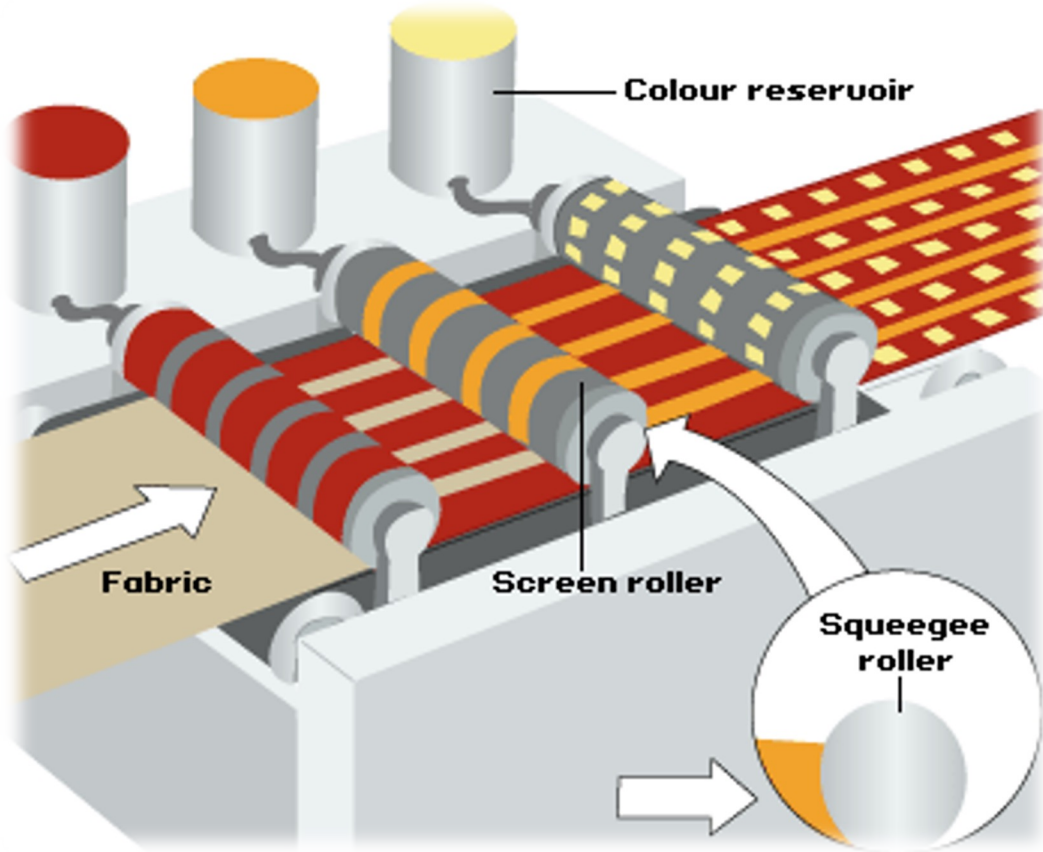

PRINTING, COATING & FINISHING SYSTEMS
ZIMMER AUSTRIA | KLAGENFURT [read more](#)

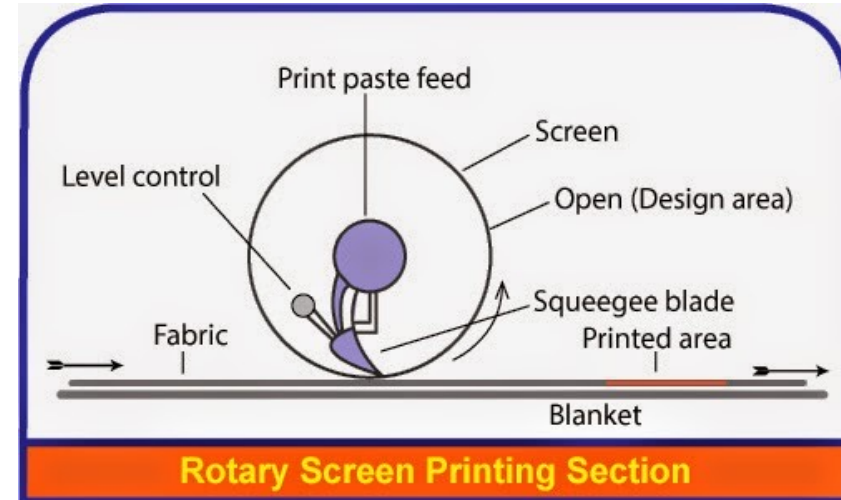

Sıcak Eriyik Kaplama



BİTİM İŞLEMLERİ ve KAPLAMA

Bu proje Avrupa Birliği ve Türkiye Cumhuriyeti tarafından finanse edilmektedir

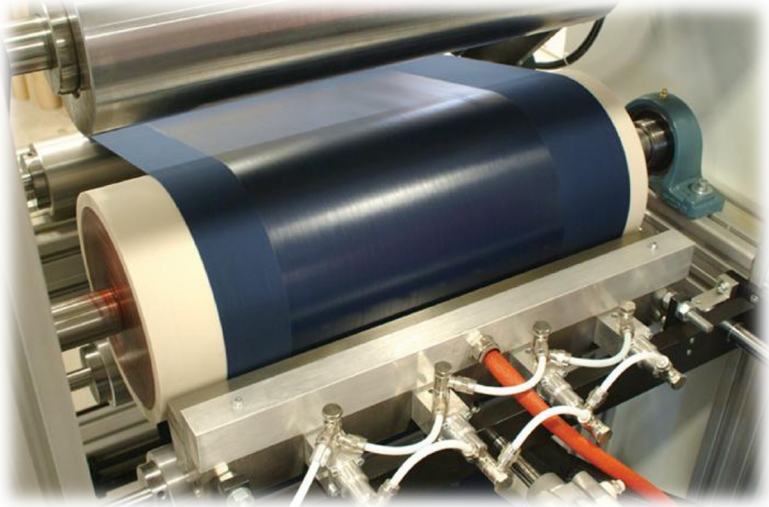
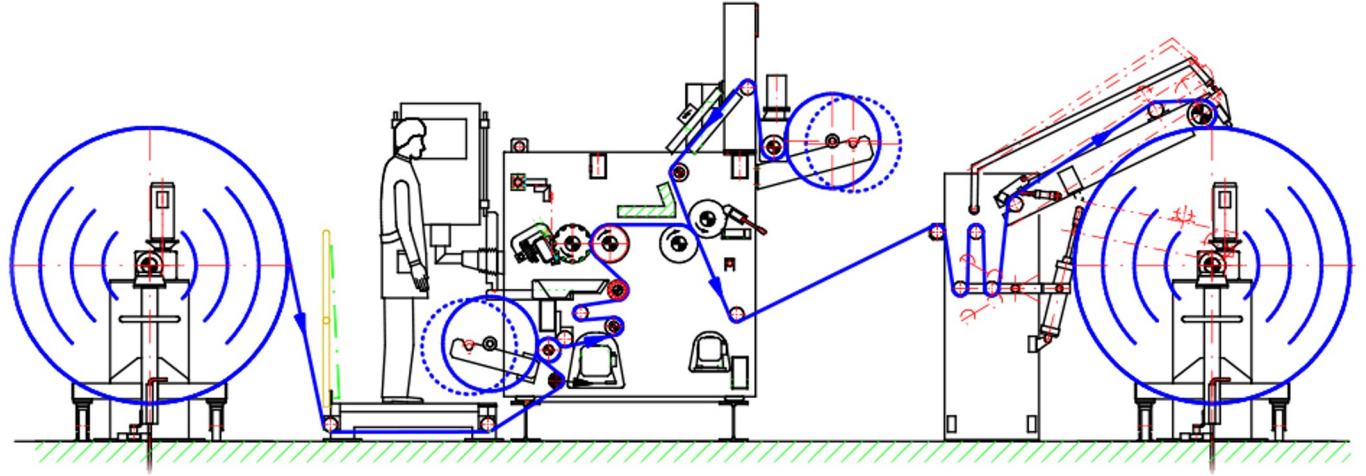
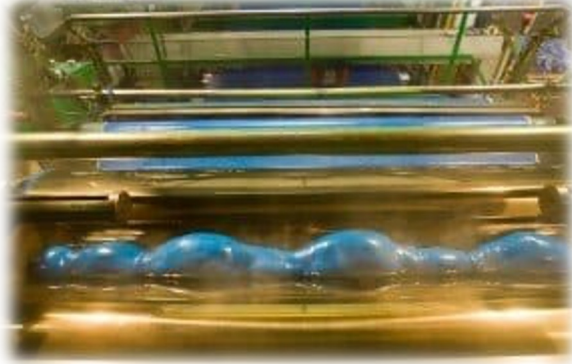

Transfer Kaplama



BİTİM İŞLEMLERİ ve KAPLAMA

Bu proje Avrupa Birliği ve Türkiye Cumhuriyeti tarafından finanse edilmektedir

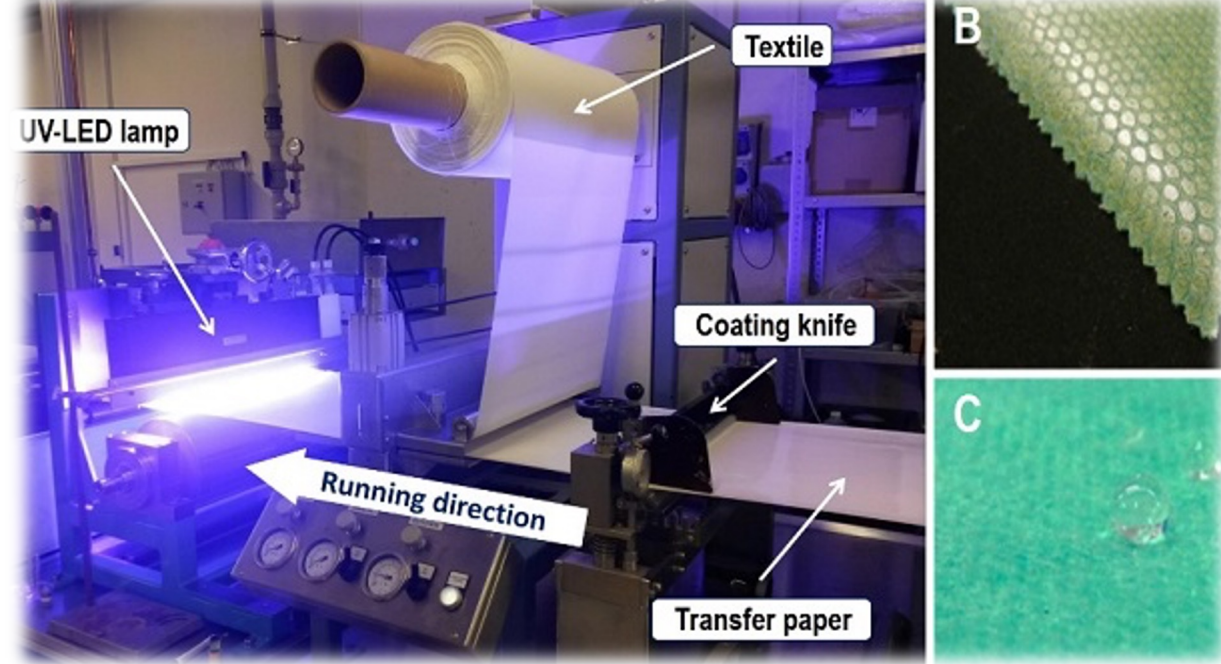
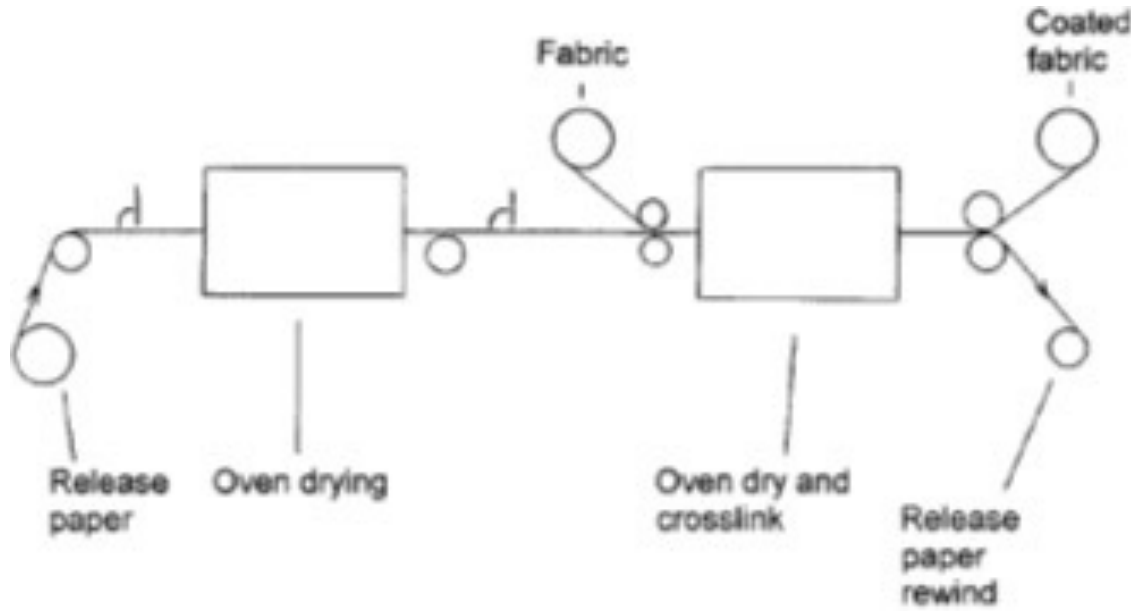

Laminasyon



BİTİM İŞLEMLERİ ve KAPLAMA

Bu proje Avrupa Birliği ve Türkiye Cumhuriyeti tarafından finanse edilmektedir

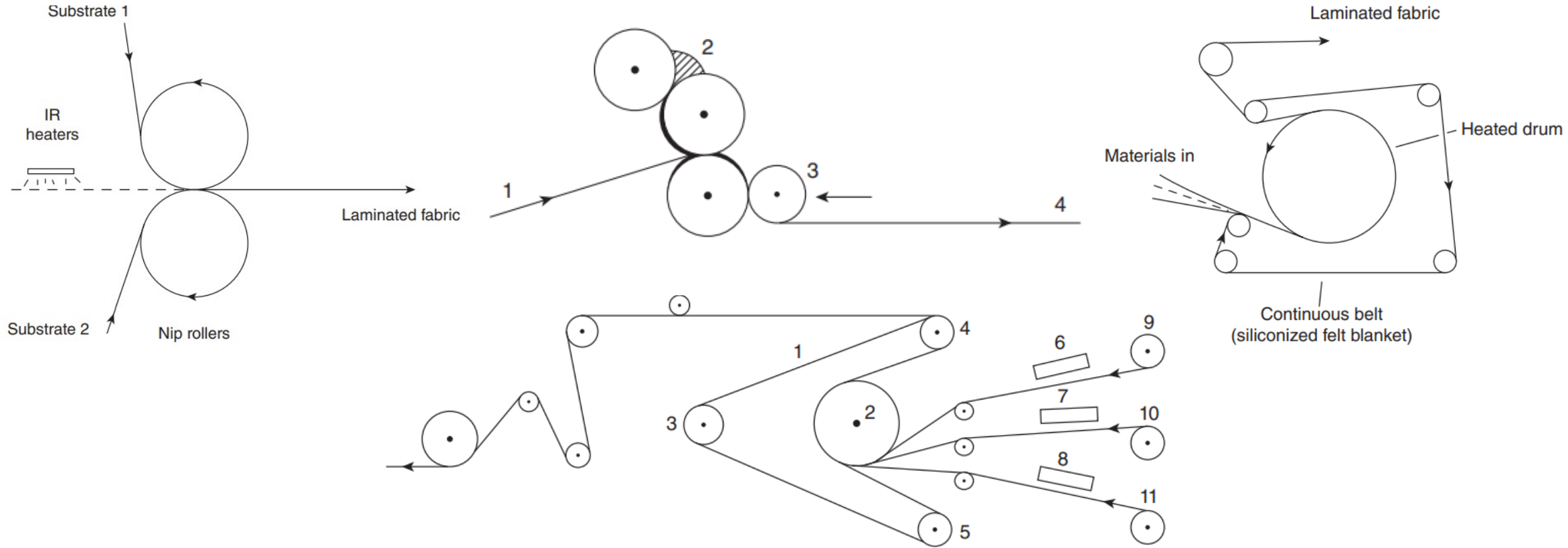

Laminasyon



BİTİM İŞLEMLERİ ve KAPLAMA

Bu proje Avrupa Birliği ve Türkiye Cumhuriyeti tarafından finanse edilmektedir

Powder scattering

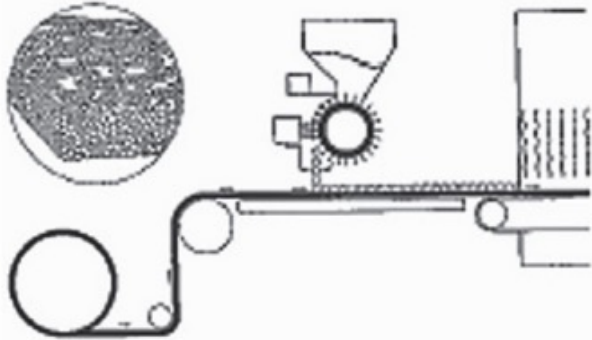

Dry powder roller printing (Powder point)

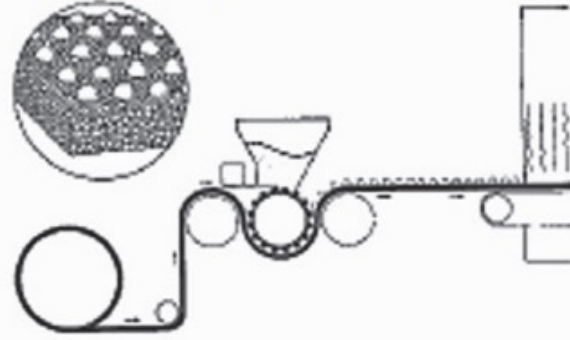

Water based paste screen dot printing

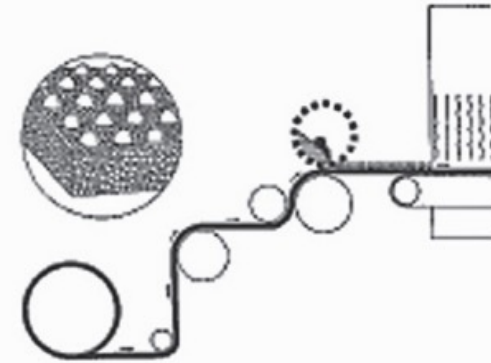

Hot melt gravure roller printing



Hot melt screen printing



Paste knife spreading

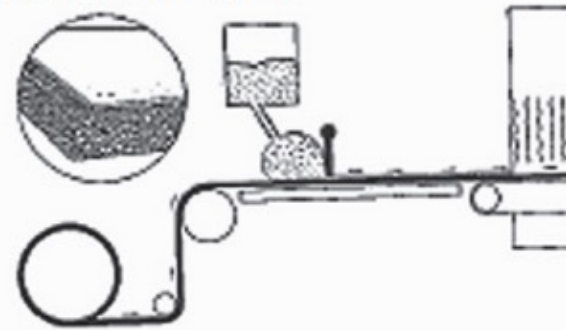



Bu proje Avrupa Birliđi ve Türkiye Cumhuriyeti tarafından finanse edilmektedir

İlginiz için Teşekkür Ederiz!

E-Mail: info@butexcomp.com



BUTEXCOMP hakkında daha fazla bilgi için:
www.butexcomp.org



@butexcomp

